



**SPARTAN
EQUIPMENT®**

Model 365 Backhoe Attachment



SERIAL NUMBER: _____

MODEL NUMBER: _____

Manual Number: OM702
Part Number: 75602
Rev. 3

SERIAL NUMBER:

MODEL NUMBER:

Manual Number: OM702

Part Number: 75602

Rev. 3

TABLE OF CONTENTS

PREFACE	3
SAFETY PRECAUTIONS	
SAFETY STATEMENTS	5
GENERAL SAFETY PRECAUTIONS	5-7
EQUIPMENT SAFETY PRECAUTIONS	8
DECALS	
DECAL PLACEMENT	9
DECALS	10-11
INSTALLATION	
GENERAL INFORMATION	12
PREPARING THE BACKHOE - SEAT ADJUSTMENT	12
BACKHOE BUCKET OPTIONS	12
NOMENCLATURE	13
MOUNTING KITS	14
3-POINT HITCH PRELIMINARY CHECKS	14-16
3-POINT HITCH ADAPTER KIT	17-23
OPERATING INSTRUCTIONS	
GENERAL INFORMATION	24
CONTROLS	24
BEFORE YOU START DIGGING	25-26
BASIC DIGGING TECHNIQUES	27-28
SPECIAL APPLICATIONS	28-32
TRANSPORTING	33
STORAGE	34
REMOVAL FROM STORAGE	34
LUBRICATION	
LUBRICATION SYMBOLS AND DIAGRAM	35-36
MAINTENANCE AND SERVICE	
GENERAL INFORMATION	37
EVERY 8 HOURS	37
EVERY 40 HOURS	37
CONTROL VALVE	38
REPLACING BUCKET TEETH	38
CHANGING BUCKETS	38
HOSE ROUTING	39
CYLINDER SEAL REPLACEMENT	40-41
TROUBLESHOOTING	42-44
SPECIFICATIONS	
BOLT TORQUE SPECIFICATIONS	45
BACKHOE SPECIFICATIONS	46
CYLINDER AND BUCKET SPECIFICATIONS	47
PRE-DELIVERY CHECK LIST	49
LIMITED WARRANTY	51

**THIS PAGE
IS INTENTIONALLY
BLANK**

PREFACE

GENERAL COMMENTS

Congratulations on the purchase of your new SPARTAN product! This product was carefully designed and manufactured to give you many years of dependable service. Only minor maintenance (such as cleaning and lubricating) is required to keep it in top working condition. Be sure to observe all maintenance procedures and safety precautions in this manual and on any safety decals located on the product and on any equipment on which the attachment is mounted.

This manual has been designed to help you do a better, safer job. Read this manual carefully and become familiar with its contents.

WARNING!  **Never let anyone operate this unit without reading the "Safety Precautions" and "Operating Instructions" sections of this manual. Always choose hard, level ground to park the vehicle on and set the brake so the unit cannot roll.**

Unless noted otherwise, right and left sides are determined from the operator's control position when facing the attachment.

NOTE: The illustrations and data used in this manual were current (according to the information available to us) at the time of printing, however, we reserve the right to redesign and change the attachment as may be necessary without notification.

BEFORE OPERATION

The primary responsibility for safety with this equipment falls to the operator. Make sure the equipment is operated only by trained individuals that have read and understand this manual. If there is any portion of this manual or function you do not understand, contact your local authorized dealer or the manufacturer.

SAFETY ALERT SYMBOL



This is the "Safety Alert Symbol" used by this industry. This symbol is used to warn of possible injury. Be sure to read all warnings carefully. They are included for your safety and for the safety of others working with you.

SERVICE

When servicing your product, remember to use only manufacturer replacement parts. Substitute parts may not meet the standards required for safe, dependable operation.

To facilitate parts ordering, record the model and serial number of your unit in the space provided on the cover of this manual. This information may be obtained from the identification plate located on the product.

The parts department needs this information to insure that you receive the correct parts for your specific model.

**THIS PAGE
IS INTENTIONALLY
BLANK**

SAFETY STATEMENTS



THIS SYMBOL BY ITSELF OR WITH A WARNING WORD THROUGHOUT THIS MANUAL IS USED TO CALL YOUR ATTENTION TO INSTRUCTIONS INVOLVING YOUR PERSONAL SAFETY OR THE SAFETY OF OTHERS. FAILURE TO FOLLOW THESE INSTRUCTIONS CAN RESULT IN INJURY OR DEATH.



DANGER

THIS SIGNAL WORD IS USED WHERE SERIOUS INJURY OR DEATH WILL RESULT IF THE INSTRUCTIONS ARE NOT FOLLOWED PROPERLY.



WARNING

THIS SIGNAL WORD IS USED WHERE SERIOUS INJURY OR DEATH COULD RESULT IF THE INSTRUCTIONS ARE NOT FOLLOWED PROPERLY.



CAUTION

THIS SIGNAL WORD IS USED WHERE MINOR INJURY COULD RESULT IF THE INSTRUCTIONS ARE NOT FOLLOWED PROPERLY.

NOTICE

NOTICE INDICATES A PROPERTY DAMAGE MESSAGE.

GENERAL SAFETY PRECAUTIONS

WARNING!

READ MANUAL PRIOR TO INSTALLATION



Improper installation, operation, or maintenance of this equipment could result in serious injury or death. Operators and maintenance personnel should read this manual, as well as all manuals related to this equipment and the prime mover thoroughly before beginning installation, operation, or maintenance. **FOLLOW ALL SAFETY INSTRUCTIONS IN THIS MANUAL AND THE PRIME MOVER'S MANUAL(S).**



READ AND UNDERSTAND ALL SAFETY STATEMENTS

Read all safety decals and safety statements in all manuals prior to operating or working on this equipment. Know and obey all OSHA regulations, local laws, and other professional guidelines for your operation. Know and follow good work practices when assembling, maintaining, repairing, mounting, removing, or operating this equipment.



KNOW YOUR EQUIPMENT

Know your equipment's capabilities, dimensions, and operations before operating. Visually inspect your equipment before you start, and never operate equipment that is not in proper working order with all safety devices intact. Check all hardware to ensure it is tight. Make certain that all locking pins, latches, and connection devices are properly installed and secured. Remove and replace any damaged, fatigued, or excessively worn parts. Make certain all safety decals are in place and are legible. Keep decals clean, and replace them if they become worn or hard to read.

GENERAL SAFETY PRECAUTIONS

WARNING!



PROTECT AGAINST FLYING DEBRIS

Always wear proper safety glasses, goggles, or a face shield when driving pins in or out, or when any operation causes dust, flying debris, or any other hazardous material.

WARNING!



LOWER OR SUPPORT RAISED EQUIPMENT

Do not work under raised booms without supporting them. Do not use support material made of concrete blocks, logs, buckets, barrels, or any other material that could suddenly collapse or shift positions. Make sure support material is solid, not decayed, warped, twisted, or tapered. Lower booms to ground level or on blocks. Lower booms and attachments to the ground before leaving the cab or operator's station.

WARNING!



USE CARE WITH HYDRAULIC FLUID PRESSURE

Hydraulic fluid under pressure can penetrate the skin and cause serious injury or death. Hydraulic leaks under pressure may not be visible. Before connecting or disconnecting hydraulic hoses, read your prime mover's operator's manual for detailed instructions on connecting and disconnecting hydraulic hoses or fittings.

- Keep unprotected body parts, such as face, eyes, and arms as far away as possible from a suspected leak. Flesh injected with hydraulic fluid may develop gangrene or other permanent disabilities.
- If injured by injected fluid, see a doctor at once. If your doctor is not familiar with this type of injury, ask him to research it immediately to determine proper treatment.
- Wear safety glasses, protective clothing, and use a piece of cardboard or wood when searching for hydraulic leaks. **DO NOT USE YOUR HANDS!**
SEE ILLUSTRATION.

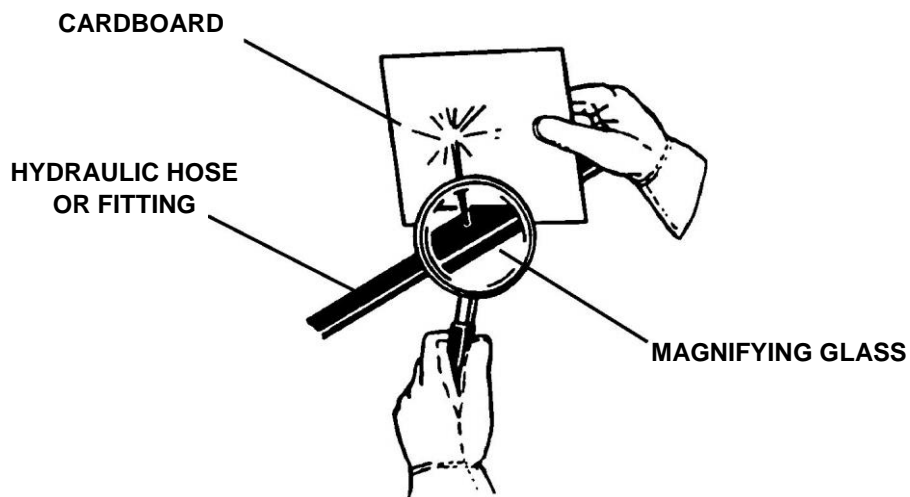

GENERAL SAFETY PRECAUTIONS

WARNING!



DO NOT MODIFY MACHINE OR ATTACHMENTS

Modifications may weaken the integrity of the attachment and may impair the function, safety, life, and performance of the attachment. When making repairs, use only the manufacturer's genuine parts, following authorized instructions. Other parts may be substandard in fit and quality. Never modify any ROPS (Roll Over Protection Structure) or FOPS (Falling Object Protective Structure) equipment or device. Any modifications must be authorized in writing by the manufacturer.

WARNING!



SAFELY MAINTAIN AND REPAIR EQUIPMENT

- Do not wear loose clothing or any accessories that can catch in moving parts. If you have long hair, cover or secure it so that it does not become entangled in the equipment.
- Work on a level surface in a well-lit area.
- Use properly grounded electrical outlets and tools.
- Use the correct tools for the job at hand. Make sure they are in good condition for the task required.
- Wear the protective equipment specified by the tool manufacturer.



SAFELY OPERATE EQUIPMENT

Do not operate equipment until you are completely trained by a qualified operator in how to use the controls, know its capabilities, dimensions, and all safety requirements. See your machine's manual for these instructions.

- Keep all step plates, grab bars, pedals, and controls free of dirt, grease, debris, and oil.
- Never allow anyone to be around the equipment when it is operating.
- Do not allow riders on the attachment or the prime mover.
- Do not operate the equipment from anywhere other than the correct operator's position.
- Never leave equipment unattended with the engine running, or with this attachment in a raised position.
- Do not alter or remove any safety feature from the prime mover or this attachment.
- Know your work site safety rules as well as traffic rules and flow. When in doubt on any safety issue, contact your supervisor or safety coordinator for an explanation.

EQUIPMENT SAFETY PRECAUTIONS

WARNING!



KNOW WHERE UTILITIES ARE

Observe overhead electrical and other utility lines. Be sure equipment will clear them. When digging, call your local utilities for location of buried utility lines, gas, water, and sewer, as well as any other hazard you may encounter.



OPERATING THE BACKHOE

Block off work area from bystanders, livestock, etc. Allow plenty of room for backhoe swing.

Operate only from the operator's station.

Use the backhoe only for digging. Do not use the backhoe to pull things, as a battering ram, or attach ropes, chains etc., to the unit.

Do not dig close to the stabilizers. The ground could collapse from under the backhoe.

Do not lift loads in excess of the capacity of the backhoe or prime mover.

When operating on slopes, dig with the backhoe uphill, and avoid swinging the backhoe to the downhill side. Avoid steep hillside operation, which could cause the prime mover to overturn.

Reduce speed when driving over rough terrain, on a slope, or turning, to avoid overturning the vehicle.

Do not adjust relief valve settings. Incorrect valve settings could result in equipment damage and/or personal injury.

An operator must not use drugs or alcohol, which can change his or her alertness or coordination. An operator taking prescription or over-the-counter drugs should seek medical advice on whether or not he or she can safely operate equipment.

Before exiting the prime mover, lower the backhoe bucket and stabilizers to the ground, turn off the prime mover's engine, remove the key and apply the brakes.

TRANSPORTING THE BACKHOE



Be sure to engage boom and swing locks before transporting backhoe to prevent uncontrolled movement.

When driving on public roads use safety lights, reflectors, Slow Moving Vehicle signs etc., to prevent accidents. Check local government regulations that may affect you. Do not drive close to ditches, excavations, etc., cave in could result.

Do not smoke when refueling the prime mover. Allow room in the gas tank for expansion. Wipe up any spilled fuel. Secure cap tightly when done.

MAINTAINING THE BACKHOE



Before performing maintenance, lower the attachment to the ground, turn off the engine, remove the key and apply the brakes.

Never perform any work on the attachment unless you are authorized and qualified to do so. Always read the operator service manual's before any repair is made.

After completing maintenance or repair, check for correct functioning of the backhoe. If not functioning properly, always tag "DO NOT OPERATE" until all problems are corrected.

Worn, damaged, or illegible safety decals must be replaced. New safety decals can be ordered from SPARTAN.

Never make hydraulic repairs while the system is under pressure, or cylinders under load. Serious personal injury or death could result.

Never work under a raised attachment.

10492 2-13-06

DECAL PLACEMENT

2.

GENERAL INFORMATION

The diagrams on this page show the location of all the decals used on the 365 backhoe. The decals are identified by their part numbers, with the reductions of the actual decals located on the following pages. Use this information to order replacements for lost or damaged decals. Be sure to read all decals before operating the backhoe. They contain information you need to know for both safety and backhoe longevity.

SERIAL TAG LOCATION 40255

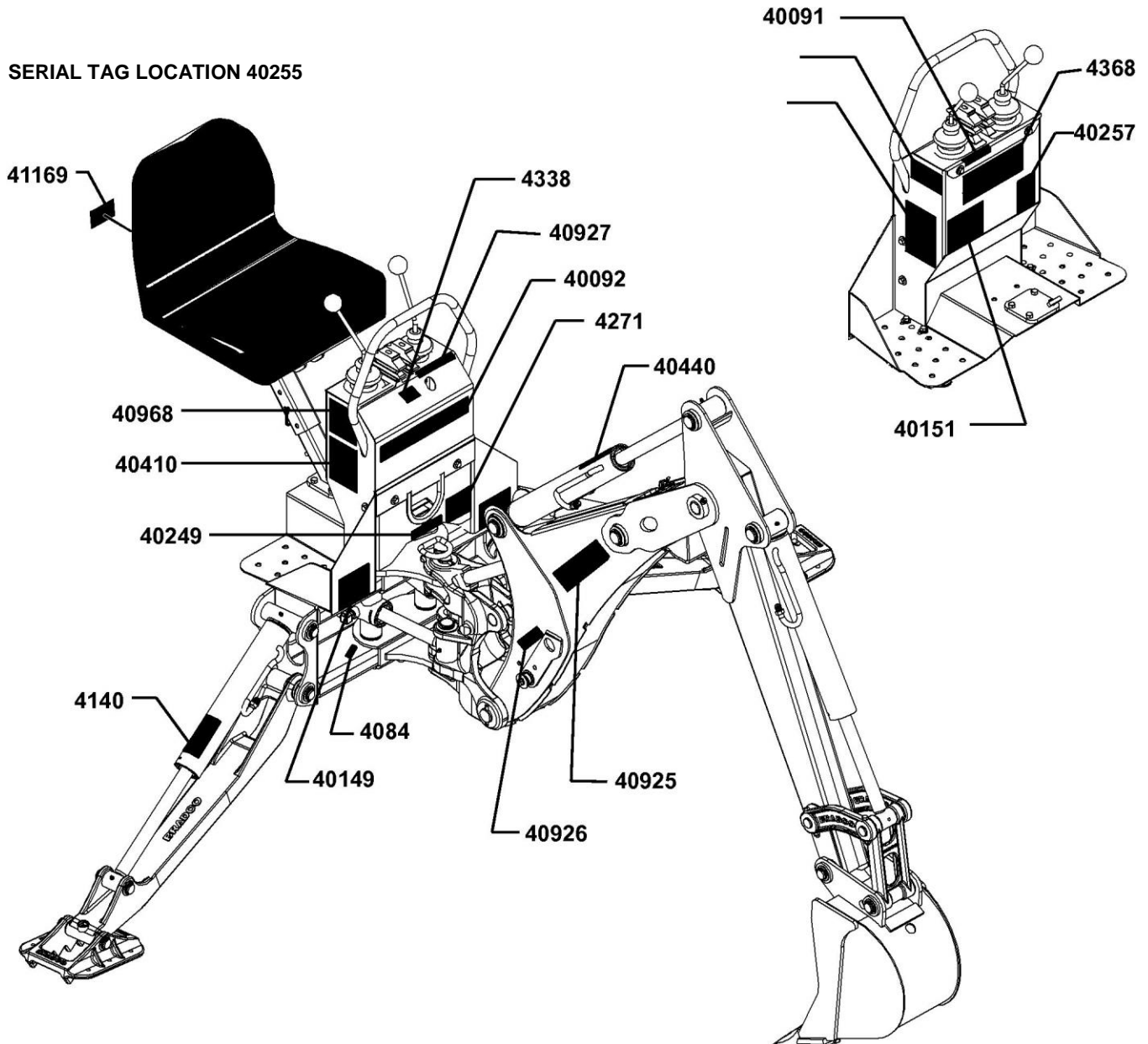

IMPORTANT: Keep all safety decals clean and legible. Replace all missing, illegible or damaged safety decals. When replacing parts with safety decals attached, the safety decals must also be replaced.

REPLACING SAFETY DECALS: Clean the area of application with a nonflammable solvent, then wash the same area with soap and water. Allow the surface to dry. Remove the backing from the safety decal, exposing the adhesive surface. Apply the safety decal to the position shown in the diagram above, and smooth out any bubbles.

10649 7-7-10-2

DECALS

IMPORTANT
 TO PREVENT BACKHOE DAMAGE:

- DO NOT ATTACH TOW CHAIN TO DIPPER OR BUCKET.
- DO NOT REPEATEDLY SLAM SWING POST INTO SWING STOPS.

PREPARATION FOR STORAGE

LUBRICATE ALL GREASE POINTS. LEAVE AS MANY CYLINDERS IN CLOSED POSITION AS POSSIBLE. COVER ALL EXPOSED CYLINDER RODS WITH A LIGHT COAT OF GREASE. #40257

PART #40257
IMPORTANT



PART #40440
 CALL BEFORE YOU DIG

WARNING

TO PREVENT SERIOUS INJURY OR DEATH:

- Do not operate or work on this machine without reading and understanding Operator's Manual.
- Avoid unsafe operation or maintenance.
- Do not operate machine with guards and covers removed.
- This machine was designed to be operated by one operator. Do not carry passengers on unit.
- Before installing backhoe on your unit extend boom and dipperstick and lower bucket to ground.
- Never use backhoe as manlift.
- Operate backhoe control levers from operator's seat only. Lower stabilizers and bucket to ground before leaving operator's seat.
- Engage boom lock and swing lock before transporting backhoe.

#40255

PART #40255
WARNING! OPERATIONAL

WARNING

KEEP AWAY

HIGH-PRESSURE FLUID HAZARD

To prevent serious injury or death:

- Relieve pressure on system before repairing or adjusting or disconnecting.
- Wear proper hand and eye protection when searching for leaks. Use wood or cardboard instead of hands.
- Keep all components in good repair.

PART #40151
WARNING! HIGH PRESSURE FLUID

DANGER

To Prevent Serious Injury or Death from Crushing:

Verify the backhoe is securely attached to the prime mover.

- Check mounting bolts for tightness.
- Visually check for proper pin engagement before operating.

#41169

PART #41169
DANGER! BACKHOE SECURE

CAUTION

365 BACKHOE AND 3-POINT LIMITATIONS

For Use On Category I Compact Tractors:
 25 - 40 Horsepower.
 800 - 2000 Lbs. Rated Hitch Lift Capacity.
 Up To 4000 Lbs. GVW.

Mounting This Backhoe On Larger Tractors May Result In Serious Damage To The Backhoe And Void Warranties.

Do Not Use 3-Point Quick Attaching Coupler To Mount Backhoe On Tractor.

Minimum Of 20% Of Tractor And Equipment Weight Must Be On The Tractor Front Wheels With The Backhoe In The Transport Position.

Sustained Heavy Use Of Backhoe May Result In Damage To The Tractor. #40968

PART #40968
WARNING! 3-POINT LIMITATIONS

IMPORTANT

The backhoe bucket is capable of contacting this stabilizer and/or cylinder. Careful operation will avoid backhoe damage. #4140

PART #4140
IMPORTANT

DANGER

KEEP AWAY

To prevent serious injury or death from pinching:

- Keep all persons and objects clear while any part of this machine is in motion.

PART #40149
DANGER! PINCH POINT

DECALS

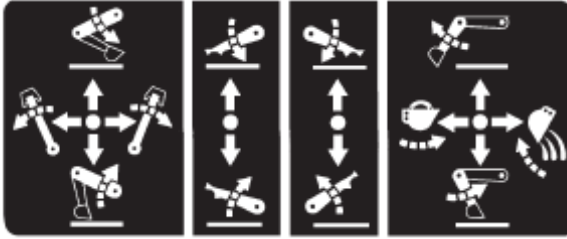

PART #4368
OPERATING CONTROLS DECAL



PART #43638
MADE IN USA



PART #4084
GREASE 8 HOURS



PART #40926
BOOM LOCK



PART #40927
SWING SPEED CONTROL

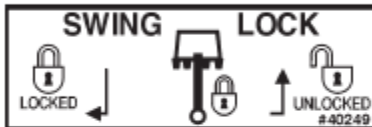

PART #40249
SWING LOCK

365

PART #40925
365 MODEL NUMBER

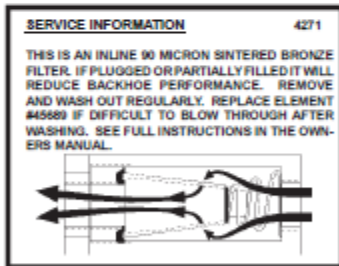

PART #4271
INLINE FILTER

IMPORTANT NOTICE REGARDING 3-POINT HITCH BACKHOES.

BRADCO MAKES NO CLAIMS OR WARRANTY, IMPLIED OR OTHERWISE, as to the compatibility or structural integrity of any tractors 3-point hitch assembly or components when used with any BRADCO 3-point hitch type backhoe. Since many models of tractors have standard category hitches and backhoes have standard category attaching points, it is possible to mount tractor or backhoe combinations that are not compatible.

DEALERS AND/OR OWNERS MUST DETERMINE THAT COMPATIBILITY BETWEEN THE TRACTOR AND BACKHOE EXISTS.

Compatibility includes, but is not limited to items such as operator clearance, hitch component strength, tractor case strength and hydraulics.

Suggestions given as to hitch categories and horsepower ranges used with various models of backhoes are suggestions only and not recommendations as to suitability of any combination of tractors and backhoes.

BRADCO also manufactures solid 4-point mounting kits for many models of tractors. These kits do NOT mount to the 3-Point hitch. If in doubt about your hitch compatibility, solid 4-point mounting type kit and backhoe should be used.

PART #40410
IMPORTANT



PART #40091
FLOAT

10651 8-7-06

INSTALLATION

GENERAL INFORMATION

WARNING! Never let anyone operate this equipment without first reading this manual, as well as all manuals related to this equipment and the prime mover. Follow all safety and operating instructions.



Operate the backhoe only from the operator's station. Any other method could result in serious personal injury or death.

Lower the backhoe bucket and stabilizers to the ground, turn off the engine, remove the key and apply the brakes before leaving the operator's station.

Check the prospective digging area for hidden utility lines before operating the backhoe. If in doubt of their location, contact the local utility companies. When operating the unit in an area where utility lines are expected to be present, proceed with caution. If the bucket makes contact with anything out of the ordinary, stop digging at once. Have the obstruction checked by hand. If a utility line has been damaged, contact the affected utility company at once.

PREPARING THE BACKHOE - SEAT ADJUSTMENT

The backhoe seat can be adjusted to facilitate operator comfort and head clearance. There is a lever under the seat for sliding forward/backward, safety snap pins on the pedestal for positioning the seat up/down and also the pedestal can be moved forward on the console assembly. Before mounting the backhoe onto your loader/tractor move the seat forward and position it into the lowest position. After installation onto the tractor the seat may be moved back if clearance is not a factor.

BACKHOE BUCKET OPTIONS

Basic backhoes are shipped complete with bucket. However, several bucket options are available for the backhoe. Refer to the table below for proper identification of backhoe bucket options.

BUCKET ASSEMBLIES

8"	#88508
10"	#88510
12"	#88512
16"	#88516
18"	#88518

Additional buckets without teeth are available upon request.

5.

INSTALLATION

NOMENCLATURE

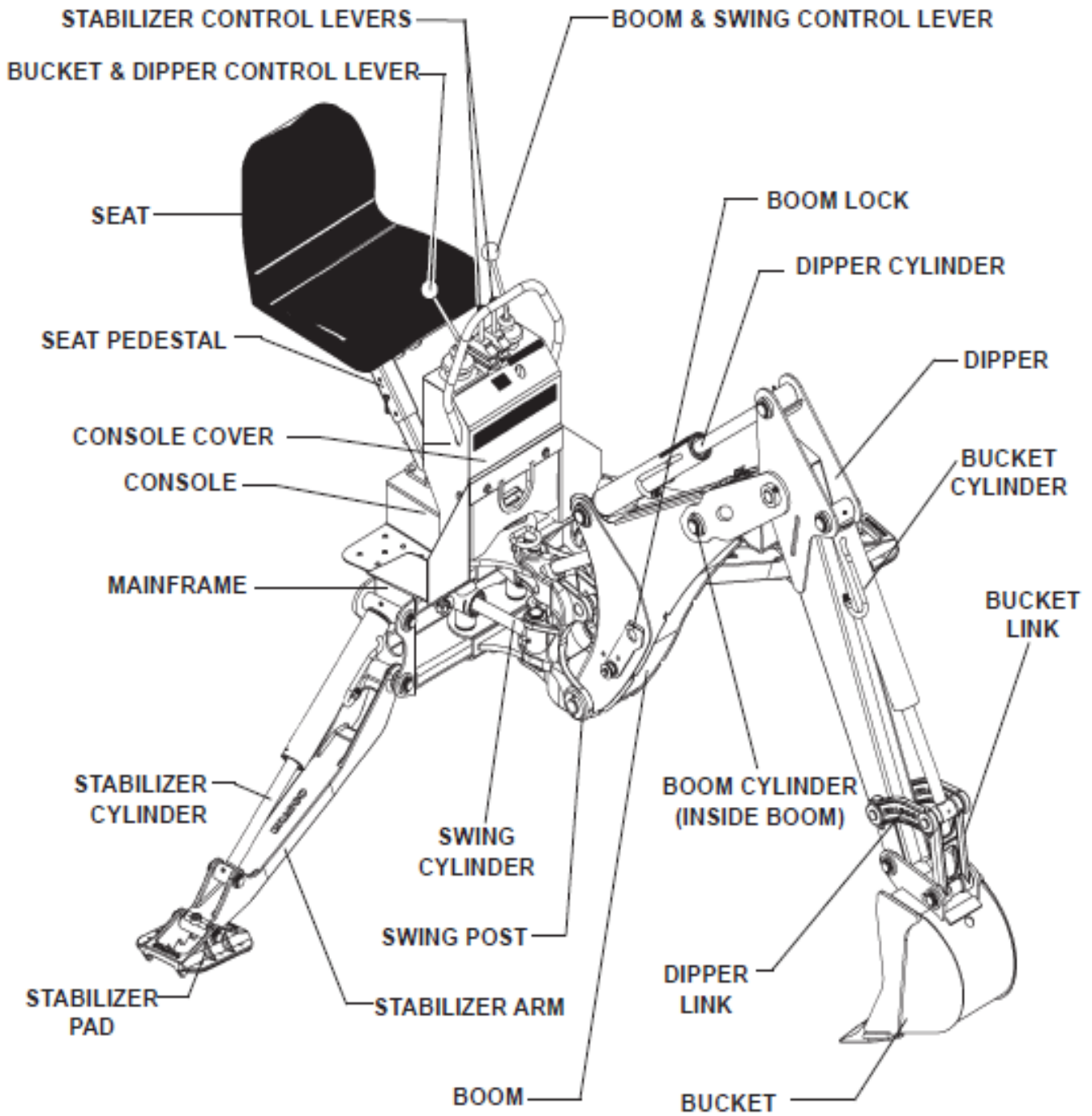

INSTALLATION

MOUNTING KITS

The three point hitch adapter kit will adapt the backhoe to any three point hitch tractor and therefore this kit will be covered in this manual to help facilitate mounting onto any compact tractor's three point hitch system.

Due to the various models of mini skid loaders that this backhoe is designed for, installation instructions for the mounting kit you have received and the backhoe itself is covered in a separate set of instructions that will address your particular combination.

IMPORTANT NOTICE REGARDING 3-POINT HITCH BACKHOES

SPARTAN makes no claims or warranty, implied or otherwise, as to the compatibility or structural integrity of any tractors 3-point hitch assembly or components when used with any SPARTAN 3-point type backhoe. Since many models of tractors have standard category hitches and backhoes have standard category attaching points, it is possible to mount tractor or backhoe combinations that are not compatible.

DEALERS AND/OR OWNERS MUST DETERMINE THAT COMPATIBILITY BETWEEN THE TRACTOR AND BACKHOE EXISTS.

Compatibility includes, but is not limited to items such as operator clearance, hitch component strength, tractor case strength and hydraulics.

Suggestions given as to hitch categories and horsepower ranges used with various models of backhoes are suggestions only and not recommendations as to suitability of any combination of tractors and backhoes.

SPARTAN also manufactures solid 4-point mounting kits for many models of tractors. These kits do NOT mount to the 3-point hitch. If in doubt about your hitch compatibility, a solid 4-point mounting type kit and backhoe should be used.

NOTICE! Sustained heavy use of this backhoe may result in damage to your tractor.

NOTICE! The 365 backhoe is designed for use on compact tractors with 25-40 horse power, 800-2000 lbs. rated hitch lift capacity and up to 4000 lbs GVW. Mounting this backhoe on larger tractors may result in serious damage to the backhoe and void warranties.

WARNING! Only use on Category I tractors.
Do not use 3-point quick attaching coupler to mount backhoe onto tractor. Minimum of 20% of the tractor and equipment weight must be on the tractor front wheels with the backhoe in the transport position.
Do not exceed ROPS certification weight.
Backhoe digging forces can lift and turn tractor over. Make sure stabilizer pads are on firm ground and avoid steep banks.



INSTALLATION

Before you install a 3-point hitch backhoe on any tractor there are certain critical points that must be checked. Failure to address these points could result in serious damage to the equipment, and serious injury or even death to the operator. Do NOT attempt to install the backhoe until you have gone through the following points and made any corrections to the equipment that might be deemed necessary.

PRELIMINARY CLEARANCE CHECK

The first point to consider is if there will be adequate clearance between the backhoe operator and the tractor. Proper clearance is essential for operator safety. When mounted, there must be a minimum of 18" horizontal clearance (with seat in forward position) and a minimum of 23" horizontal clearance (with seat in the extended position). There must also be a minimum vertical clearance of 8" between the operator's head and any portion of the tractor.

Follow the procedure below to check for minimum clearances.

6. With the tractor 3-point hitch lower links set approximately 8" to 9" off the ground, measure the horizontal distance between the lower link ball joint and any object that comes the closest to interfering with the backhoe seat (such as the ROPS or cab). See Figure #1

FIGURE #1

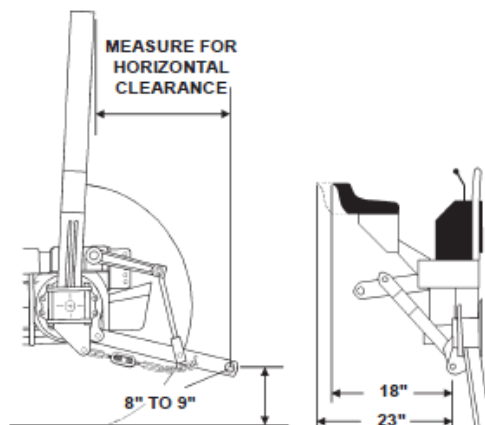
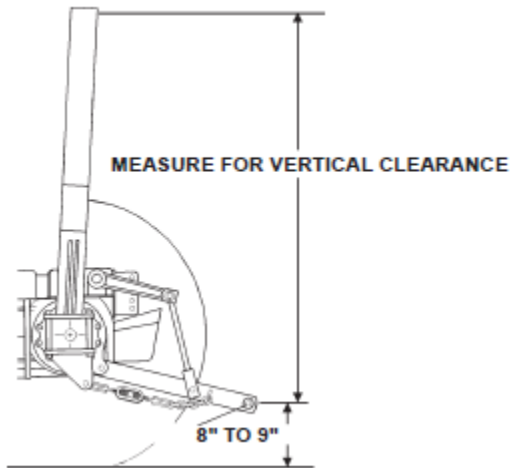

Figure #1 also shows the minimum horizontal distances between the seat (in the forward and the extended positions) and the lower link mounting point. The distance found in step #1 must be greater than these distances to safely operate the backhoe. Do not mount the backhoe if the distance found in step #1 is less than the 18" minimum. (If the distance found in step #1 is greater than 18" but less than 23" make sure the seat is in the forward position.)

INSTALLATION

2. To check the vertical clearance, first make sure the lower links are approximately 8" to 9" off the ground. Measure the vertical distance between the lower link ball joint center and any solid object that could interfere with the backhoe operator's head (such as the tractor cab or ROPS). See Figure #2

FIGURE #2



The distance found in step #2 must be at least 78". This distance allows for the height of the backhoe, the height of the seated operator, and the minimum 8" clearance. This figure assumes the operator is 6' tall. You will have to add $1/2$ " for every inch your operator is over 6' to achieve the correct figure. The distance found in step #2 must be greater than this distance to safely operate the backhoe. Do not mount the backhoe if the distance found in step #2 is less than the 78" minimum.

INSTALLATION 3- POINT HITCH ADAPTER KIT

7.

GENERAL INFORMATION

The following instructions will help you to mount your backhoe onto a category 1 three-point hitch system. Remember to read all safety warnings, decals, and operating instructions before operating the tractor or backhoe.

WARNING! Three point hitch backhoes used on tractors equipped with either ROPS or cabs can be dangerous and may cause injury or death if not properly installed, operated and maintained.



Always read the operator's manual.

Always maintain an 8" clearance between the operator and the cab or ROPS.

Always use pins of the proper size and grade at the 3-point hitch points.

MOUNTING INSTRUCTIONS

1. Remove the top link from the tractor.
2. If the tractor is equipped with draft control, render it inoperable. If this is not possible, adjust the draft lever to its heaviest load position.
3. Remove the steel shipping banding from around the backhoe and skid.
4. Remove the seat pedestal from the console and mainframe. See Figure #1
5. Position the upper support bracket on the mainframe and reinstall the seat bracket using the longer .38" UNC X 2.00" cap screws, lock washers and hex nuts provided. See Figure #1

FIGURE
#1

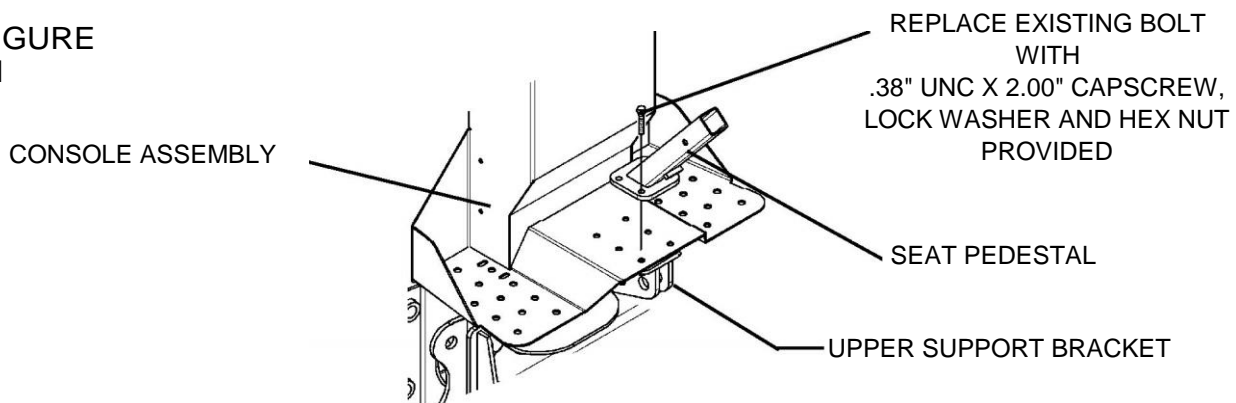

6. Secure the upper support bracket to the mainframe using two of the .75" UNC X 2.50" cap screws, hard flat washers, lock washers and nylock nuts provided. See Figure #2

10612 7-20-06

INSTALLATION

3-Point Hitch Adapter Kit

8.

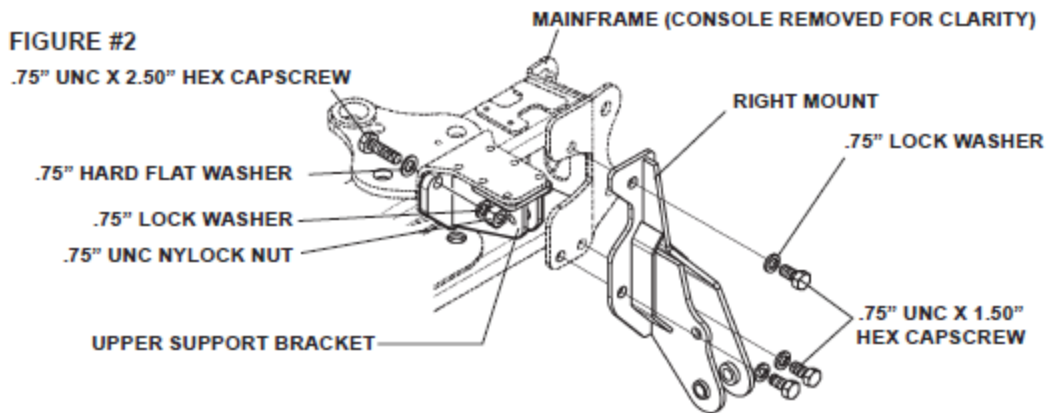

7. Install the left and right mounts onto the back of the mainframe using the six .75" UNC X 1.50" capscrews and lock washers provided. See Figure #2
8. Install the center single link between the ears of the upper support bracket using the pivot pin #86620, thrust washers #57462 and snap rings #6612. See Figure #3
9. Install the center double link onto the tractor top link location using the existing high strength pin supplied by your tractor manufacturer. See Figure #3

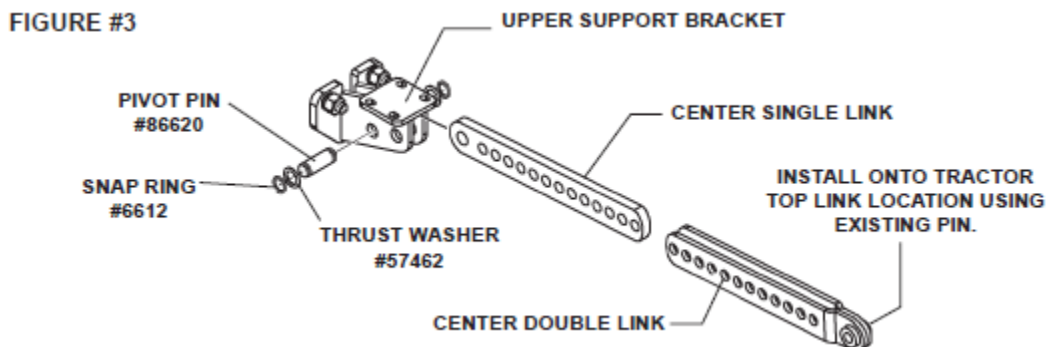

10. Connect the two #38474 power and return hoses to the two hoses coming from the backhoe valve. (The hose on the left goes to the backhoe inline filter and the hose on the right comes from the backhoe check valve.)
11. Connect the couplers (purchased from your dealer) onto the power and return hoses. Install the male coupler to the hose on the right coming from the check valve and the female coupler to the hose on the left going to the inline filter.

10613 7-20-06

10.

INSTALLATION 3- POINT HITCH ADAPTER KIT

- Following the proper operating procedures listed in your tractor operator's manual, slowly back the tractor up to the backhoe. (Back the tractor only close enough to connect the hydraulic system.

WARNING! Escaping fluid under pressure can have sufficient force to penetrate the skin causing serious personal injury. Fluid escaping from a very small hole can be almost invisible. Use a piece of cardboard or wood, rather than hands to search for suspected leaks.



Keep unprotected body parts, such as face, eyes, and arms as far away as possible from a suspected leak. Flesh injected with hydraulic fluid may develop gangrene or other permanent disabilities.

- Hook up the hydraulic system to the tractor.

We recommend that you involve your dealer for the initial hydraulic hook-up and to install the correct hydraulic couplers that fit your tractor onto the backhoe power and return hoses.

- Start the tractor engine and operate at low RPM. Activate the tractor valve to provide power to the backhoe. (Check for any hydraulic leaks.)

CAUTION! Until the backhoe is securely mounted onto the tractor keep all people clear of your work area and make sure that no portion of the operator's body is beneath any part of the backhoe.



- Raise the backhoe using the stabilizer and boom control levers until the swing post is approximately eight to nine inches above ground level. Make sure the backhoe is vertical (perpendicular to the ground). See Figure #4

FIGURE
#4

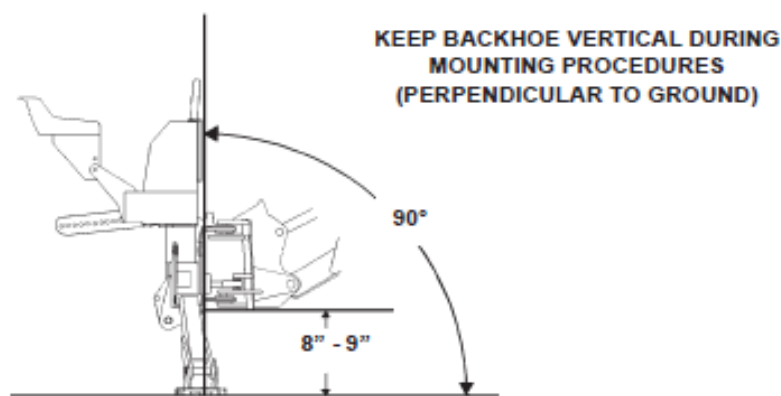

INSTALLATION 3- POINT HITCH ADAPTER KIT

12.

16. Back the tractor until the lower link ball joints are in line with the mounting holes in the left and right mounts. NOTE: While backing tractor be aware of the location of the hydraulic hoses and top links.

17. Install the (2) #1987 hitch pins connecting the lower links to the left and right mounts. Secure in place using the two hair pins provided. See Figure #5

FIGURE #5

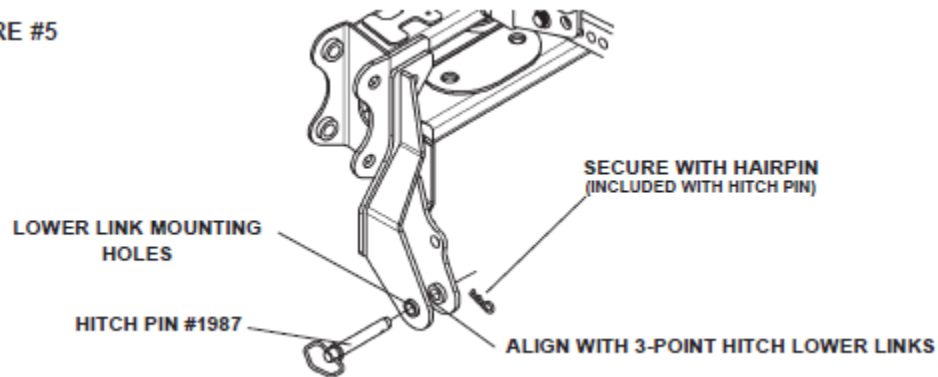

18. Position the center single link in-between the center double link. Adjust the backhoe height until at least one hole lines up between the two links. Keep the backhoe vertical while adjusting the height. Install the .75" UNC X 2.50" capscREW, hard flat washers (both sides) and nylock nut provided. See Figure #6

19. If the hitch arm locks were not installed at the factory, position them to the inside of the mounting holes and bolt into place using the two .75" X 2.00" capscREWS, hard flat washers (both sides) and lock nuts provided. Position the hitch lock out arms on each side of the center top links, align one of the holes (as far away from the capscREW installed in step #18 as possible) and install the .75" x 4.00" capscREW, two hard flat washers (both sides) and lock nut provided. See Figure #6

FIGURE #6

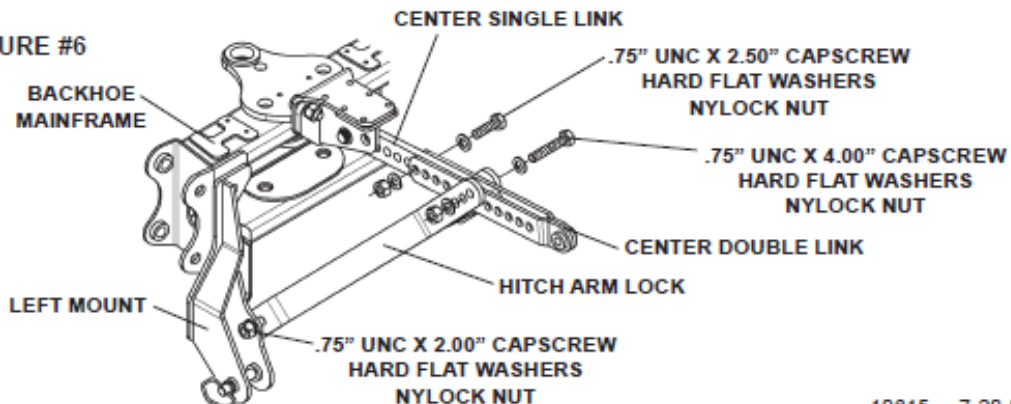

10615 7-20-06

INSTALLATION

3-POINT HITCH ADAPTER KIT

It is important to pick a set of holes that place the backhoe in a vertical position in relationship to the ground with 8" - 9" of ground clearance at the boom pivot pin.

20. Torque all .75" mounting bolts to 270-324 ft. lbs. Refer to Bolt Torque Specifications chart in the backhoe operator's manual.
21. Check hose routing to ensure that all hoses are kept away from the operator during operation and are not touching the ground. Secure all hydraulic lines in place for operator safety and to prevent them from being damaged.
22. Double check clearance between the backhoe operator and any solid portion of the tractor, such as the cab or ROPS. If 8" of head clearance is not available DO NOT USE THIS BACKHOE ON THIS TRACTOR. Failure to observe these instructions may cause severe personal injury or death.

CAUTION! Do not attempt to modify the mounting in any way. Incorrect mounting or modifying of the backhoe 3-point mounting could allow the backhoe to raise up during use, resulting in injury or death.



IMPORTANT: DO NOT attempt to raise the backhoe with the 3-point hitch. The backhoe center links along with the hitch lock out arms make the backhoe a solid mount that is immovable. Any attempt to raise the backhoe with the 3-point hitch will cause the hydraulic lift oil to go over relief and eventually damage the hydraulic system due to excessive heat build-up.

3-POINT HITCH ADAPTER KIT

ASSEMBLY #107100

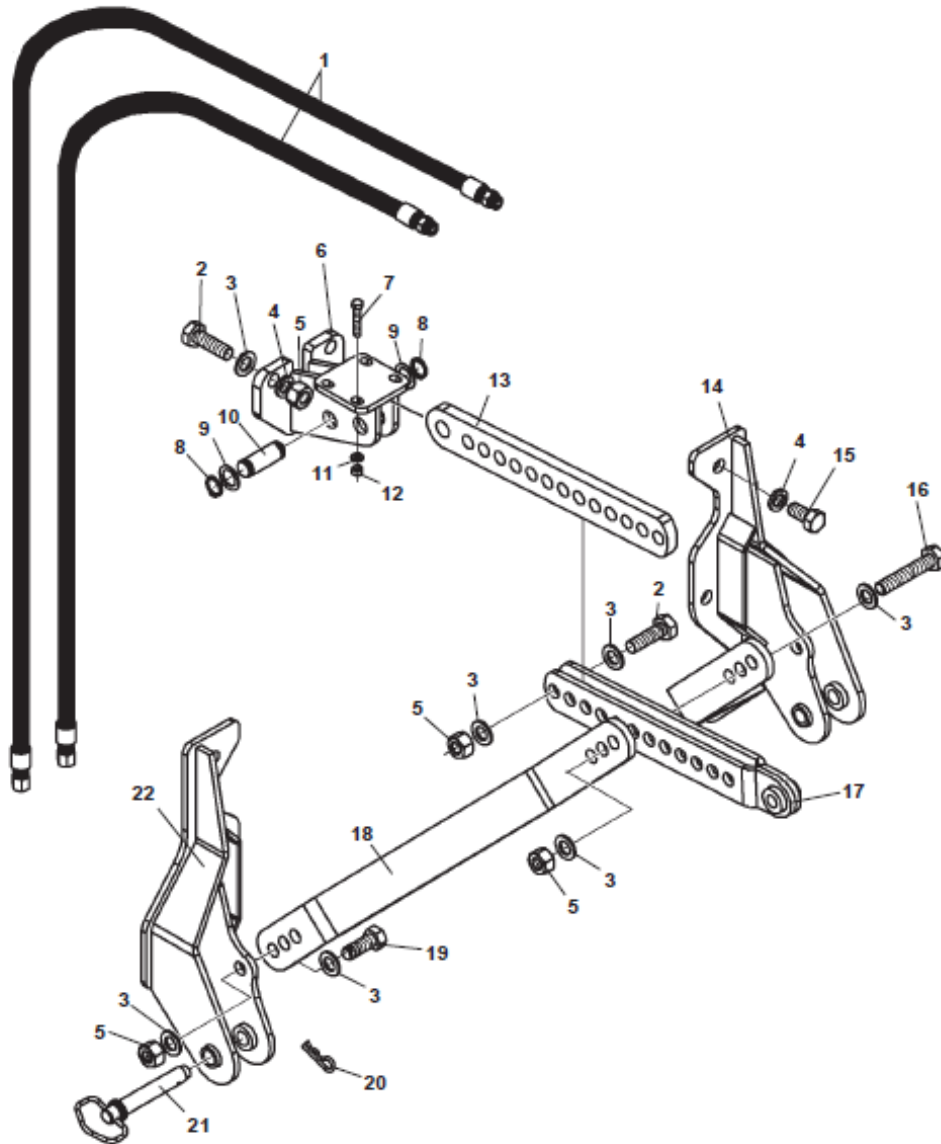

3-POINT HITCH ADAPTER KIT

ASSEMBLY #107100

<u>ITEM</u>	<u>REQ'D</u>	<u>PART NO.</u>	<u>DESCRIPTION</u>
1	2	38474	Hose .50" X 40" 8MBo-8FJX
2	3	1141	.75" UNC X 2.50" Hex Capscrew
3	10	1649	.75" Hard Flat Washer
4	8	1507	.75" Lock Washer
5	6	1534	.75" UNC Nylock Nut
6	1	106319	Upper Support Bracket
7	4	1047	.38" UNC X 2.00" Hex Capscrew
8	2	6612	Snap Ring
9	2	57462	Thrust Washer
10	1	86620	Pivot Pin
11	4	1503	.38" Lock Washer
12	4	1226	.38" UNC Hex Nut
13	1	107101	Center Single Link
14	1	107097	Right Mount
15	6	1137	.75" UNC X 1.50" Hex Capscrew
16	1	1147	.75" UNC X 4.00" Hex Capscrew
17	1	107548	Center Double Link
18	2	107549	Hitch Arm Lock
19	2	1139	.75" UNC X 2.00" Hex Capscrew
20	--	1985	Replacement Hairpin
21	2	1987	Hitch Pin (Included Hairpin #1985)
22	1	107092	Left Mount

10611 7-19-06

OPERATING INSTRUCTIONS

GENERAL INFORMATION

Your backhoe is operated by four different control levers. Two are for stabilizer operation and the other two operate the swing, boom, dipper, and bucket functions. The information contained below will help you become familiar with the operation of each control lever. Read the safety precautions (Section B) of this manual before attempting to use the backhoe. Remember, right and left when referred to on this page are determined by the operator's position seated at the backhoe controls facing the bucket.

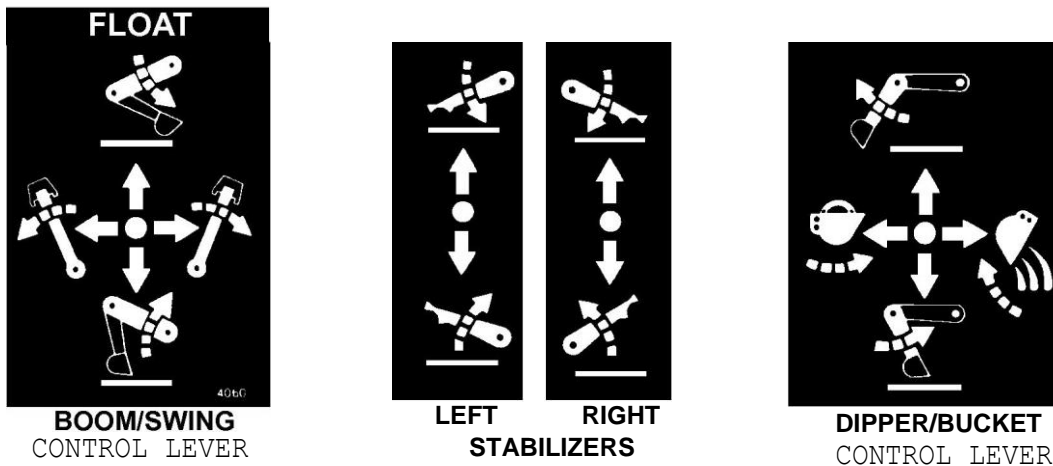

BACKHOE STABILIZER LEVERS

Moving the stabilizer lever(s) forward will bring the backhoe stabilizer (s) "Down". Moving the stabilizer lever(s) backward will raise the backhoe stabilizers "Up". Both stabilizers are required to be down for proper stability of the backhoe when in operation.

BOOM/SWING LEVER (LEFT HAND LEVER)

Pushing the boom/swing lever forward will "Lower" the boom dipstick and bucket. Full forward is the "FLOAT" position. Pulling the lever backward will "Lift" the boom, dipstick, and bucket.

Pushing the boom/swing lever to the left will swing the boom and bucket to the "Left". Pushing the lever to the right will swing the boom, and bucket to the "Right".

DIPPER/BUCKET LEVER (RIGHT HAND LEVER)

Pushing the dipper/bucket lever forward will move the dipper "Out" or away from the operator. Pulling the lever backward will move (crowd) the dipper "In" or toward the operator.

Pushing the dipper/bucket lever to the left will "Fill" or curl the bucket (move inward). Pushing the lever to the right will "Dump" the bucket (move outward).

OPERATING INSTRUCTIONS

OPERATING TECHNIQUES ATTACHMENT

TYPE BACKHOES

GENERAL INFORMATION

When operating the backhoe, smoothness of technique should be strived for at all times. Smoothness will come with experience and practice at feathering the controls. Establish a flowing digging cycle to increase operator efficiency and save unnecessary wear on the machine.

Observe the following points to obtain the best results and to fully utilize the digging force of the backhoe.

WARNING! Operate the backhoe only when seated at the controls. Any other method could result in serious personal injury or death.



Never attempt to drive the tractor when seated at the backhoe controls.

Check the prospective digging area for hidden utility lines before operating the backhoe or when in doubt of their location, contact the local utility companies. When operating the backhoe in an area where utilities are expected to be present, throttle the backhoe down and proceed with caution. If you feel the backhoe bucket made contact with anything out of the ordinary, stop digging at once. Have the obstruction checked by hand. If a utility line has been damaged, contact the affected utility at once.

BEFORE YOU START DIGGING

Before any excavating is started, it is always a good idea to plan out the job first. Various things need to be considered and taken into account prior to the actual digging. The operator should inspect the job site and take notice of any potential hazards in the area. He should have a complete understanding of the tasks he is expected to perform. Figure out what will be done with the spoil (excavated soil), will it be used to backfill or be trucked out? What are the soil conditions like? Will you have to work around others? Etc.

Once you have become familiar with the job site and understand the job requirements, it is time to set up for the actual digging. Position the backhoe in such a way as to minimize repositioning the unit and to maximize digging efficiency. Consider the placement of spoil and position the backhoe to be able to dig the maximum amount of soil, accurately, while leaving enough room for the spoil removed to be piled in the desired area.

OPERATING INSTRUCTIONS

OPERATING TECHNIQUES ATTACHMENT

TYPE BACKHOES

BEFORE YOU START DIGGING (CONTINUED)

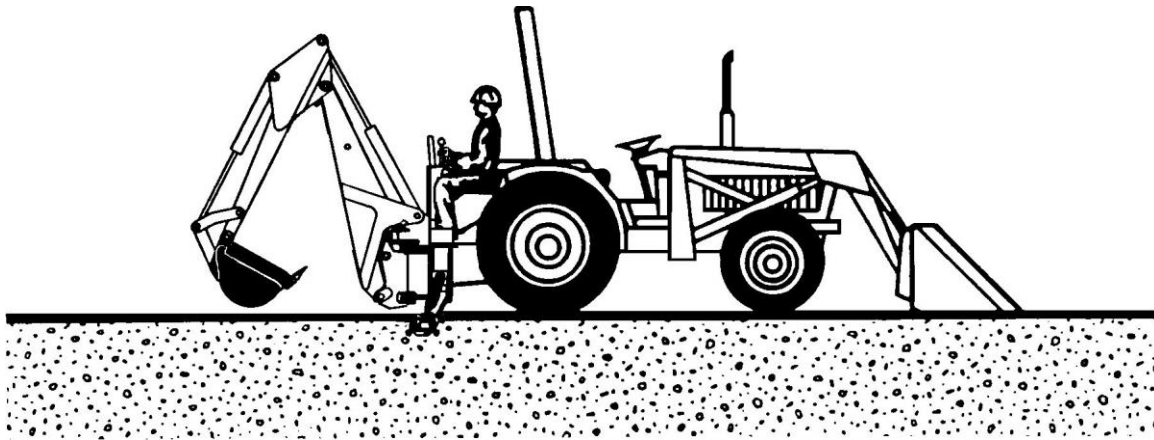

Once the unit is positioned, lower the stabilizers to the ground. The tires should still be supporting most of the vehicle weight with the stabilizers relieving only part of the weight, and mainly acting to give the unit a wider base for increased stability and to keep the unit from moving or bouncing with backhoe use. The front end loader should also be lowered if the unit is so equipped. The vehicle should at no time be supported by the stabilizers and loader with any of its wheels off the ground. Severe damage to the vehicle could result. When operating the unit on a delicate surface (such as concrete, or stone work) or on sandy, loose, or soft ground place plywood under the stabilizers to help distribute the load over a wider area.

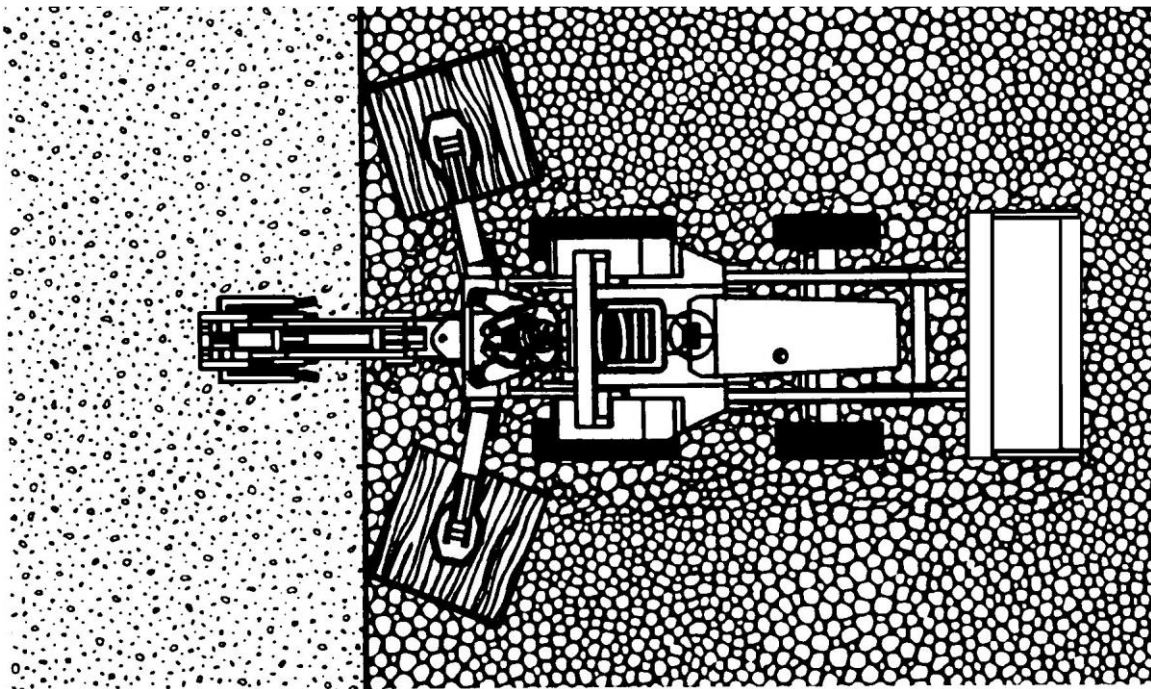

OPERATING INSTRUCTIONS

OPERATING TECHNIQUES ATTACHMENT

TYPE BACKHOES

BASIC DIGGING TECHNIQUE

When starting an excavation, make the first cut of each section shallow, being careful to follow the exact layout of the excavation. The reason for the shallow cut is to minimize damage to the sod and to facilitate replacement. These first cuts are also important because they will act as guides for the remaining cuts, thus getting the first few cuts as accurate as possible will help in keeping all future cuts accurate.

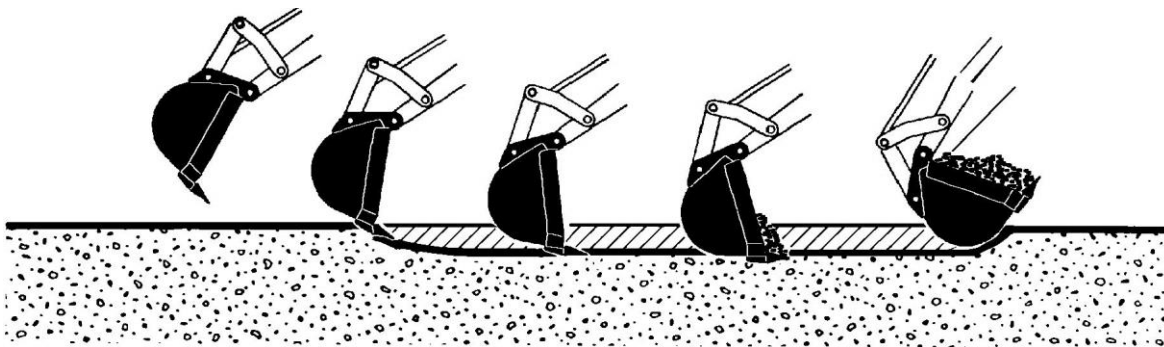

When digging with the backhoe, extend the boom, dipper and bucket out, away from the operator. Lower the boom and dipper to start the digging process. The bucket teeth should be at a 30° to 45° entry angle. As the digging starts, curl the bucket until the cutting edge is level with the horizon. Crowd the bucket in toward the operator working the bucket lever to keep the bucket level. As the bucket moves toward the operator, manipulate the boom lever to keep the cut level. At the end of the digging cycle, crowd the dipper out and completely curl the bucket while lifting it from the excavation. Once you have cleared the excavation, swing the bucket to the spoil pile. Start to dump the bucket before the pile is approached. Once the bucket is empty, swing the unit back to the excavation, positioning the bucket and dipper for the next cut in the process. The whole digging process should be one smooth cycle that is repeated until the excavation is completed.

When the excavation has been dug to within six inches of the finished bottom, clear and touch up the sides of the excavation. Use the flat sides of the bucket to scrape off any high spots. Dislodge any exposed rocks if they seem loose. When finishing walls, finish the far wall by curling the bucket out, crowding the dipper out, and forcing the bucket down. To finish the closest wall, lift the bucket up and curl it in.

OPERATING INSTRUCTIONS

OPERATING TECHNIQUES ATTACHMENT

TYPE BACKHOES

BASIC DIGGING TECHNIQUES (CONTINUED)

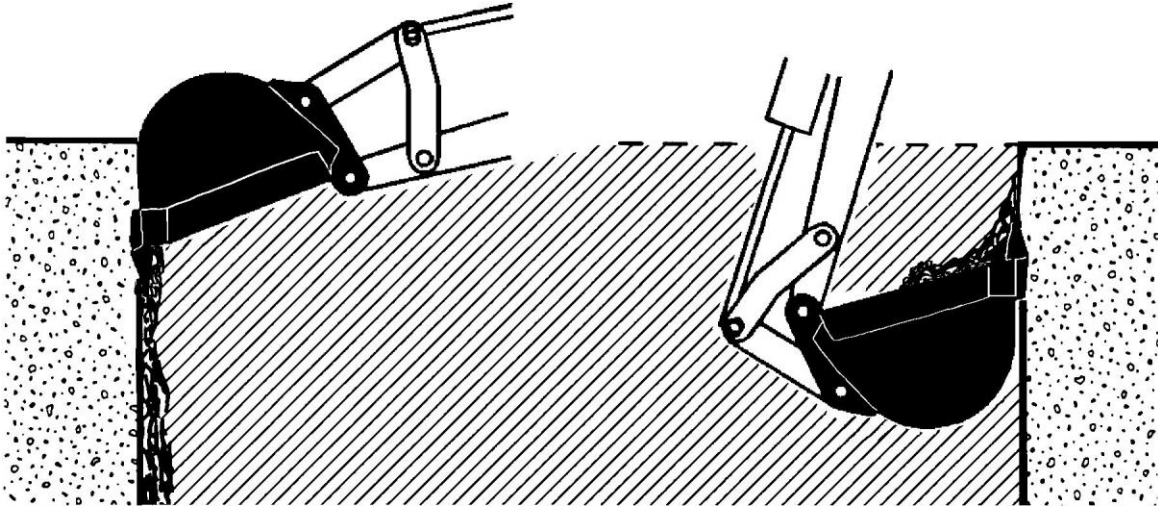

Once the sides are cleaned up, finish grading the bottom of the excavation. This is done by making the remaining cuts long and shallow, concentrating on making them level and smooth. Remove any remaining spoil. Check the excavation bottom for depth and levelness, making any adjusting cuts as needed.

The basic steps just listed at the same regardless of the excavation. All other digging jobs are simply variations of this basic procedure. Remember to make your cuts in smooth cycles. This will reduce operator fatigue and machine wear while increasing productivity and efficiency.

SPECIAL APPLICATIONS

TRENCHING BETWEEN A BUILDING AND AN OPEN EXCAVATION

Start the trench at the building and trench toward the open excavation. Dig toward the open excavation until there is just enough room to move the unit out from between the trench and open excavation.

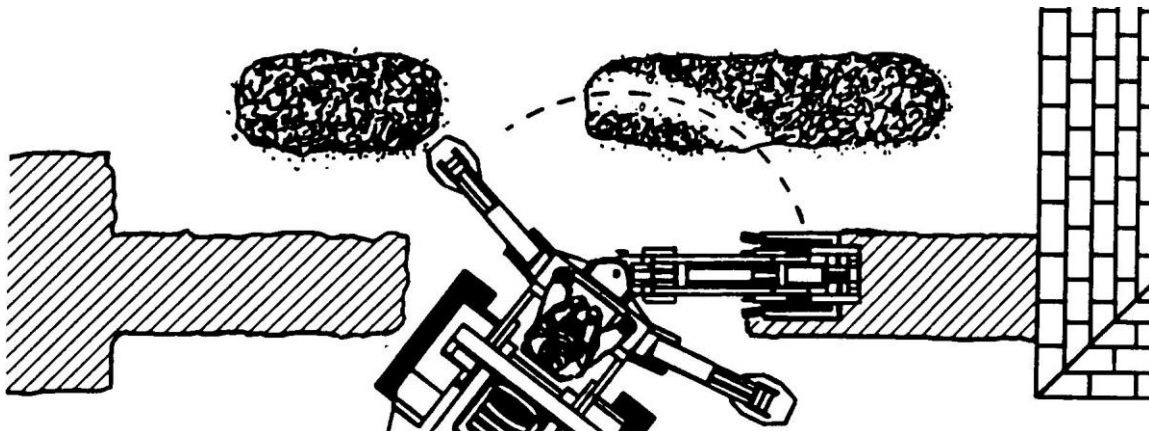

6757 8-10-06-2

OPERATING INSTRUCTIONS
OPERATING TECHNIQUES ATTACHMENT
TYPE BACKHOES

**TRENCHING BETWEEN A BUILDING
AND AN OPEN EXCAVATION (CONTINUED)**

Position the unit so the backhoe swing post is over the center line of the trench connection. Dig with the backhoe at extreme swing positions, and in as close to the stabilizers as possible. Pile the soil on the opposite side of the trenches.

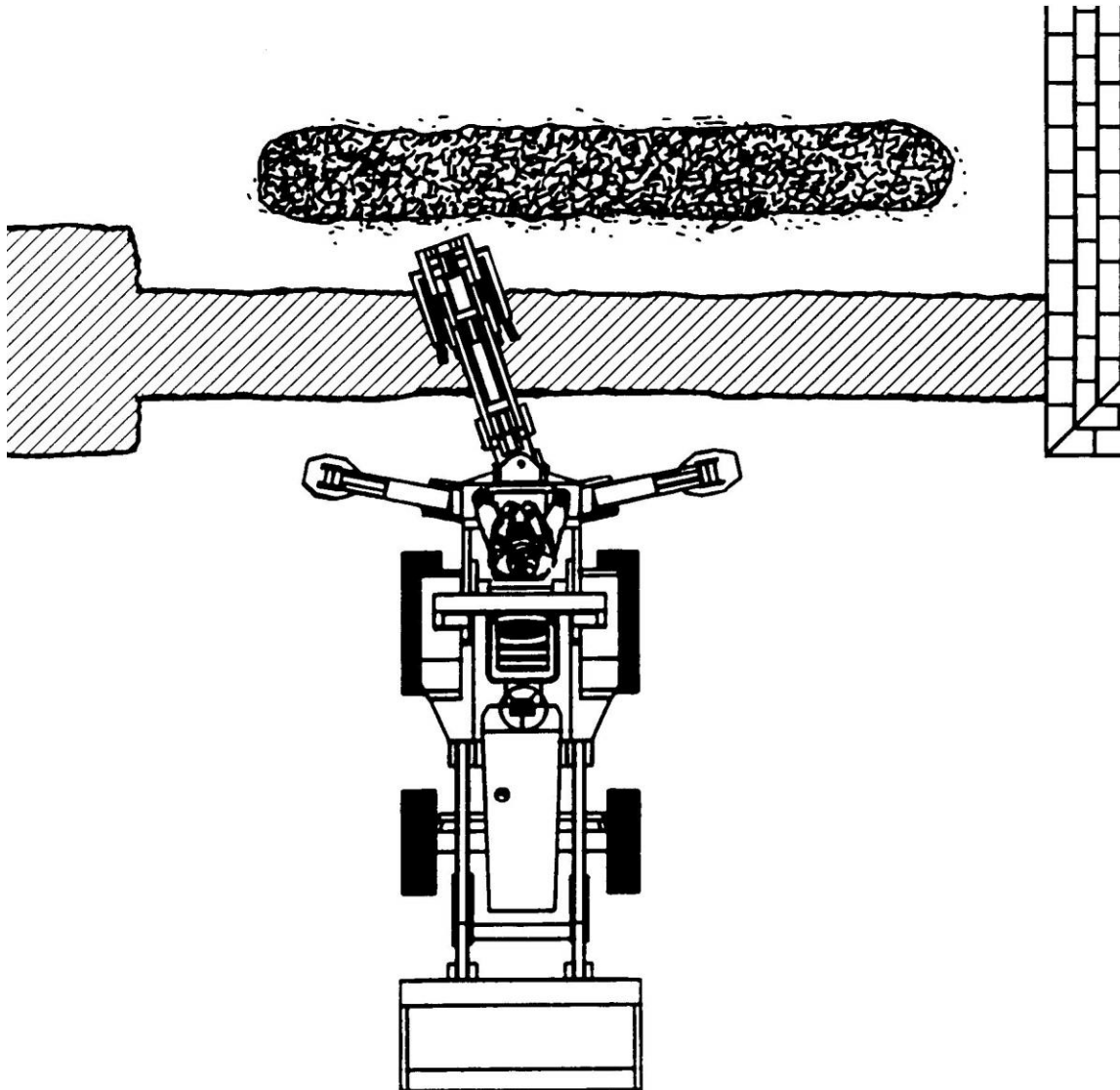

Position the unit forward so the two trenches can be connected. Pile the spoil on the opposite side of the trench.

OPERATING INSTRUCTIONS

OPERATING TECHNIQUES ATTACHMENT

TYPE BACKHOES

14.

EXCAVATING ON SLOPES

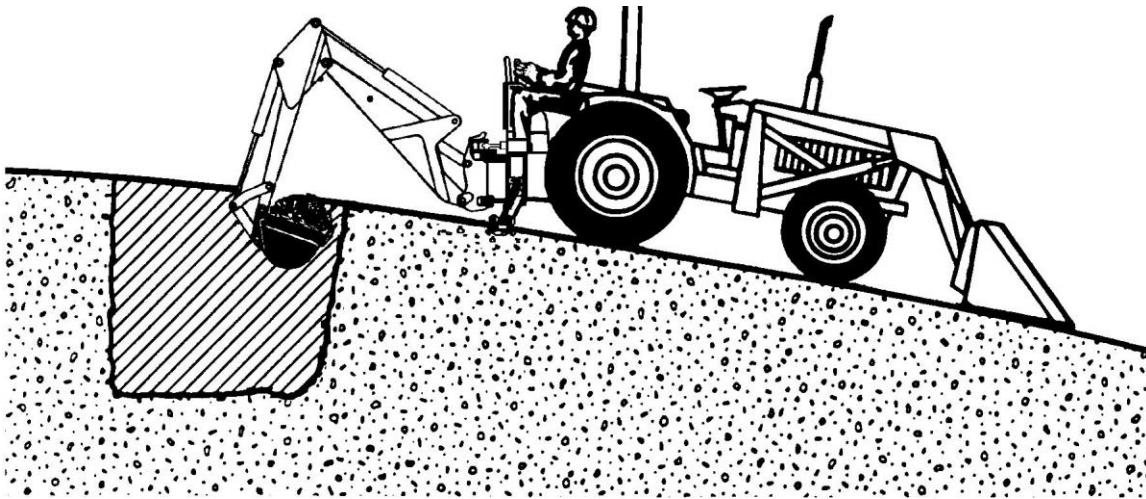

When digging on slopes always face the backhoe upgrade whenever possible. It may be necessary to cut a level surface in the hill for the backhoe to sit in when operating on slopes. This will allow the backhoe to sit level for digging the main excavation. Pile the spoil from the surface downhill. When digging the main excavation, pile the spoil uphill.

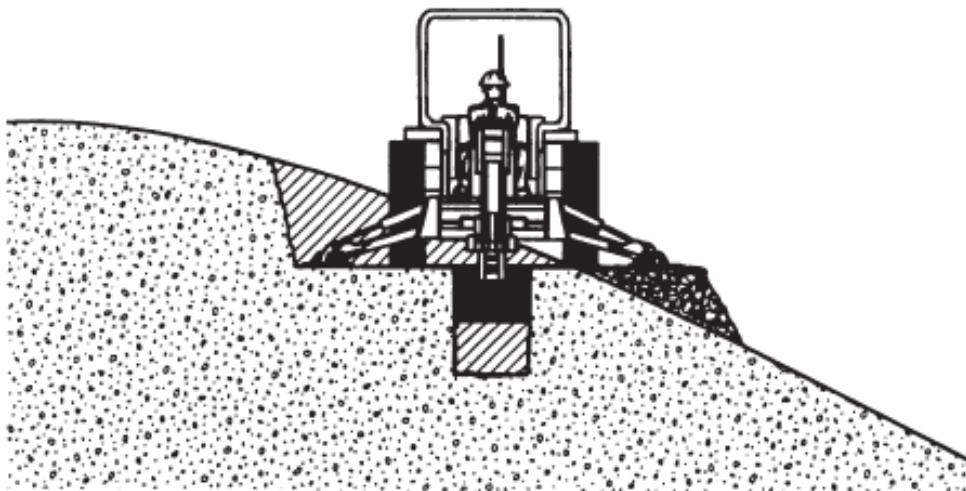

OPERATING INSTRUCTIONS

OPERATING TECHNIQUES ATTACHMENT

TYPE BACKHOES

15.

PIPELINE LEAK REPAIR

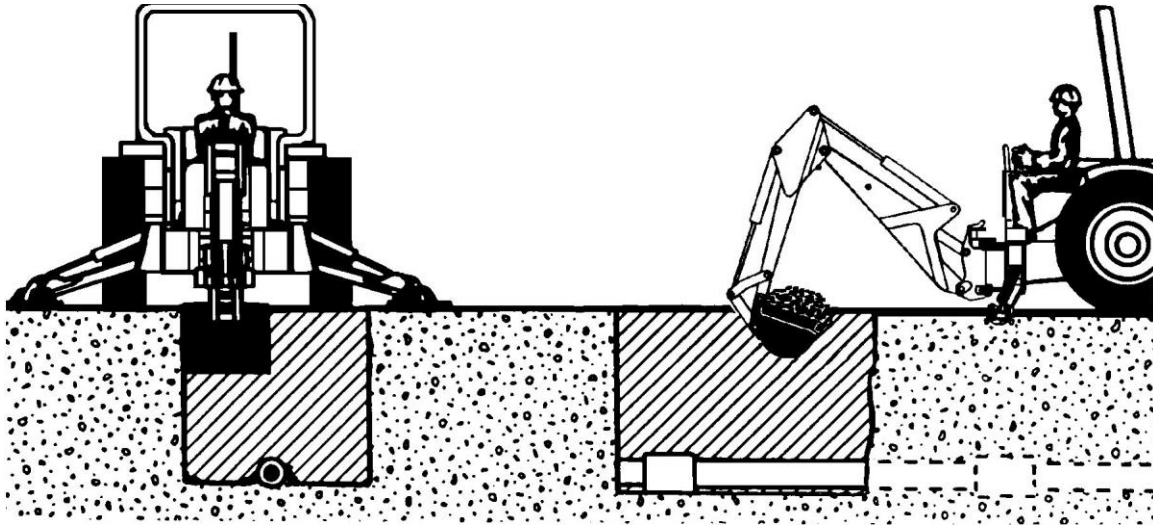

To check for pipeline leaks, start by digging a bellhole about six feet wide and ten feet long. Then, dig lengthwise along the pipeline to locate the leak. Once the leak is located, position the unit to dig at grade level on both sides of the pipeline. If a section of pipe is to be replaced, strip the soil from both ends of the bellhole. Enlarge the hole enough to allow the workmen adequate working space in the leak area.

DIGGING STRAIGHT WALL SHALLOW BASEMENTS

Begin at one corner, and remove as much material as possible to grade level. Reset the unit forward and continue digging to the grade level. Progress around the edge of the basement, finishing each corner as you come to it.

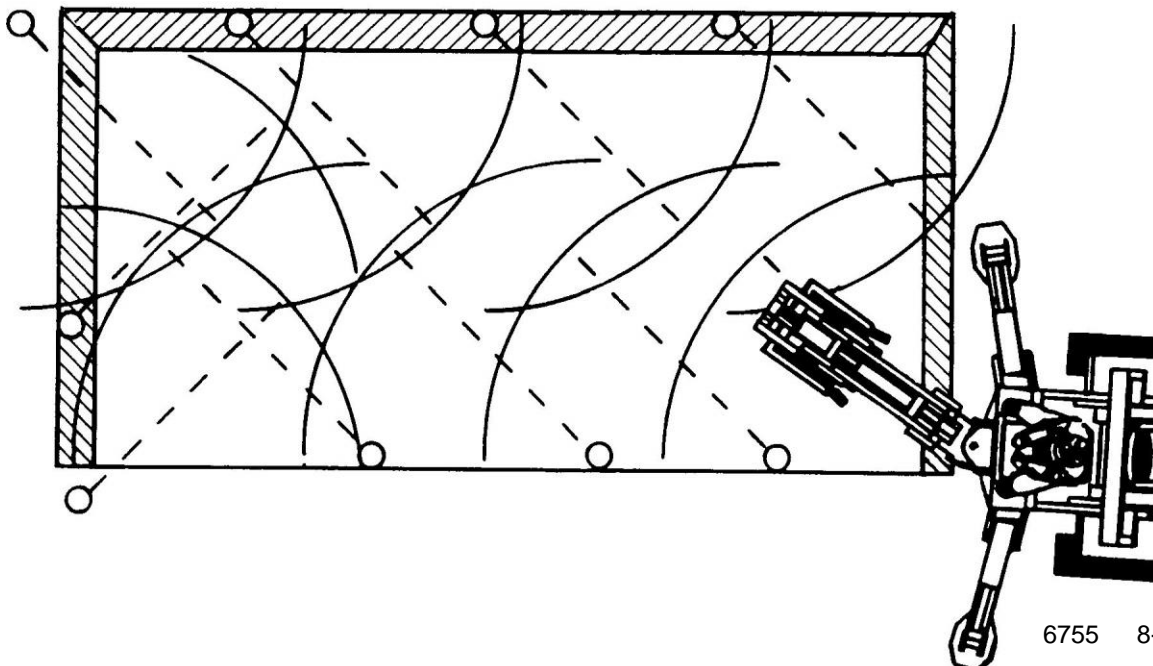

6755 8-10-06-2

OPERATING INSTRUCTIONS

OPERATING TECHNIQUES ATTACHMENT

TYPE BACKHOES

MISCELLANEOUS - BACKFILLING

To backfill an excavation, lower the extended bucket into the spoil pile. Curl the bucket and lift it clear of the spoil pile. Swing the bucket to the excavation and extend the bucket. Return the bucket to the spoil pile and continue the cycle until the job is completed.

IMPORTANT: Do not backfill by using the swing circuit and dragging the bucket sideways. Doing so could cause damage to the dipper, boom, and swing cylinders or mainframe.

IMPORTANT: Avoid constant jarring or hammering contact between the spoil pile and the loaded bucket as this may cause premature wear to the backhoe pins and bushings.

MISCELLANEOUS - EXCAVATING BY A WALL

To excavate by a wall, where the wall will interfere with the stabilizer placement, move the backhoe in at an angle to the wall. Concentrate on getting the swing pin as close to the wall as possible while leaving enough swing arc left to dump the spoil.

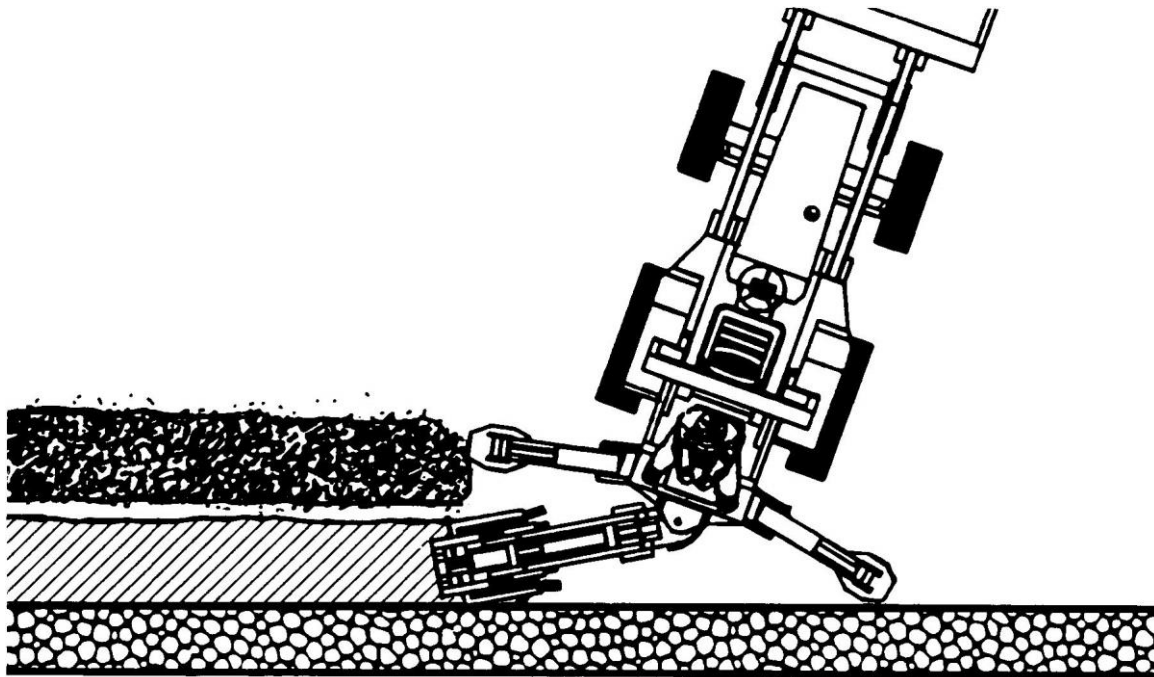

MISCELLANEOUS - HARD GROUND OPERATION

When digging in hard ground, it may be necessary to decrease the bucket angle of entry to the point where the back of the bucket almost contacts the ground. It may also be necessary to apply downward pressure with the boom on the bucket.

OPERATING INSTRUCTIONS

TRANSPORTING

GENERAL INFORMATION

Follow the simple steps listed below when preparing the backhoe for transportation between work sites. Read and follow the safety precautions for backhoe transporting listed in safety section of this manual before moving the backhoe.

1. Before transporting the backhoe, raise the boom, dipper, and bucket to the transporting position.
2. Install the swing lock pin.
3. Engage the boom lock by moving the boom lock handle to the left/down therefore locking the boom to the swing post in the transporting position.
4. Raise all stabilizers.

CAUTION! Be sure to install a SMV (Slow Moving Vehicle) sign on the backhoe dipper before attempting to transport the backhoe.



When transporting the backhoe on a road or highway at night or during the day, use accessory lights and devices for adequate warning to the operators of other vehicles. In this regard, check local government regulations.

Always drive slowly over uneven terrain to avoid tipping the backhoe.

OPERATING INSTRUCTIONS

BACKHOE STORAGE

To prepare the backhoe for storage, first wash off all dirt and grime from the unit. Coat the exposed portions of the cylinder rods with grease. Lubricate all grease fittings. Make sure that backhoe hydraulic system is properly sealed against contaminants entering the unit. When storing the backhoe, place the unit in a clean dry place with a cover over the unit if possible.

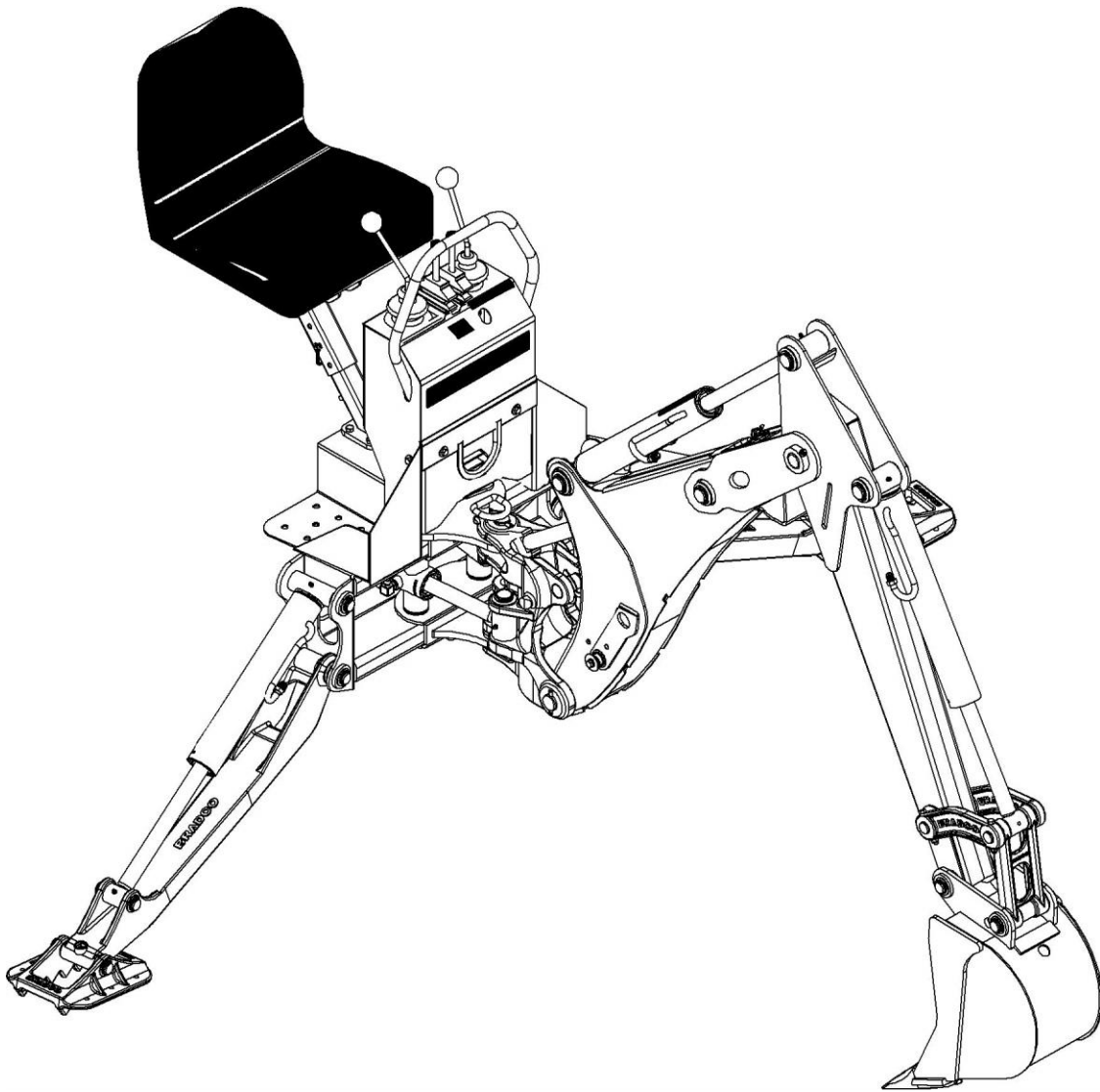

REMOVING FROM STORAGE

- Wash off all dirt and grime from the unit. This will assist you in making a visual inspection and help avoid overlooking any worn or damaged components.
- Check all hydraulic hoses and fittings for damage before installing the backhoe onto your power unit. (Check for leaks after the backhoe has been properly installed.)
- Check all lubrication points to ensure there is sufficient grease for smooth operation.
- Check all bolts for tightness.

LUBRICATION

GENERAL INFORMATION

Economical and efficient operation of any machine is dependent upon regular and proper lubrication of all moving parts with a quality lubricant. Neglect leads to reduced efficiency, heavy draft, wear, breakdown, and needless replacement parts.

All parts provided with grease fittings should be lubricated as indicated. If any grease fittings are missing, replace them immediately. Clean all fittings thoroughly before using grease gun.

IMPORTANT: Avoid excessive greasing. Dirt collects on exposed grease and greatly increases wear. After greasing, wipe off excessive grease from fittings.

LUBRICATION SYMBOLS

The following symbol is used on the lubrication diagram printed on the following page. It is reproduced here with its meaning for your convenience.



Lubricate daily or every 8 hours of operation, whichever comes first, with SAE Multi-Purpose Lubricant or an equivalent SAE Multi Purpose type grease.

CAUTION! Shut off vehicle engine before lubricating equipment.



LUBRICATION

BACKHOE LUBRICATION DIAGRAM

The following diagram is provided to help you locate all the points on your backhoe that need lubricating. Be sure to follow the lubrication intervals as noted by the lubrication symbols used on this page. Always replace any missing grease fittings as soon as possible.

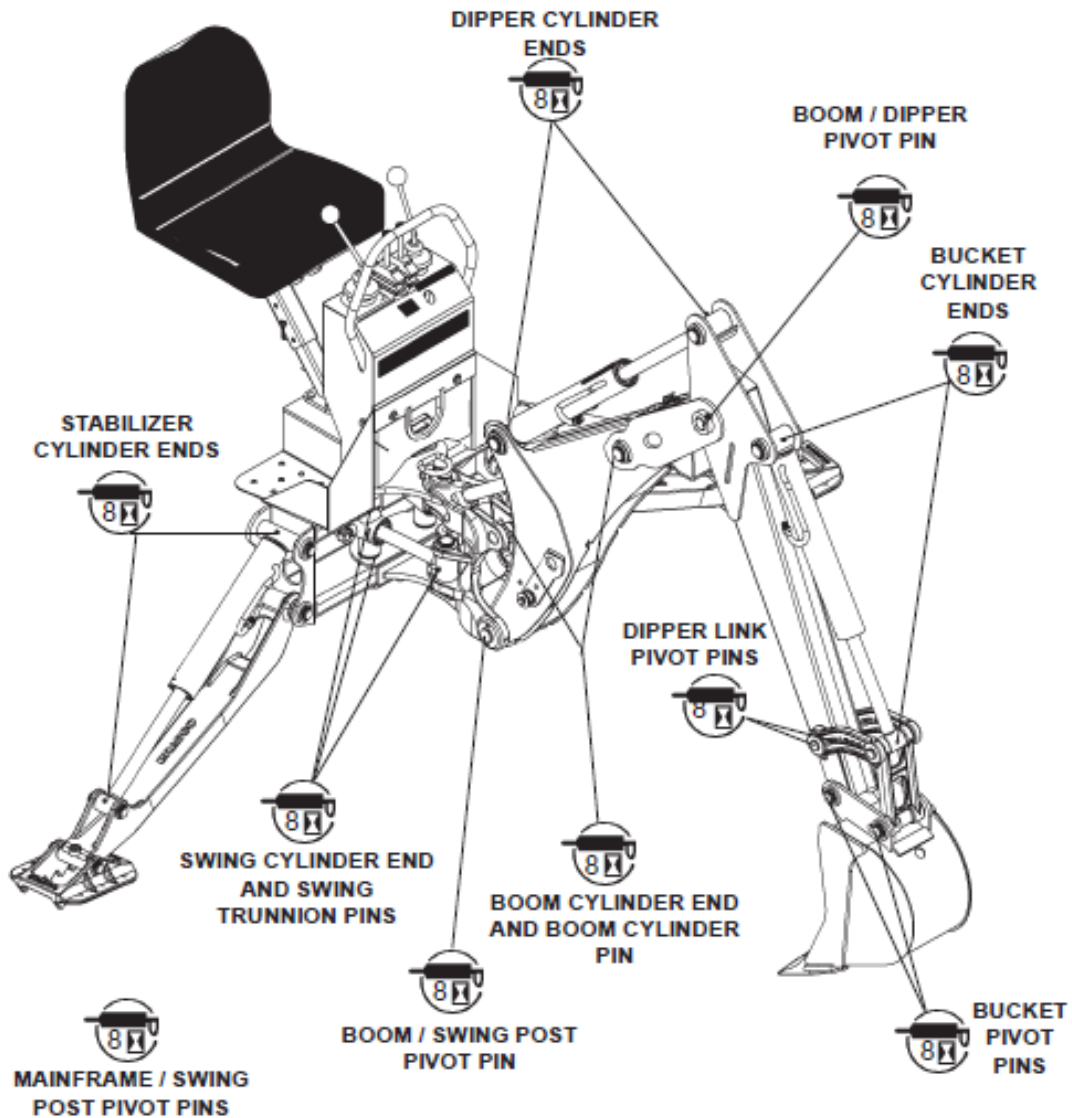

MAINTENANCE AND SERVICE

GENERAL INFORMATION

Regular maintenance is the key to long equipment life and safe operation. Maintenance requirements have been reduced to an absolute minimum. However, it is very important that these maintenance functions be performed as described below.

EVERY 8 HOURS OF OPERATION

Grease all swivel points (ram and base end of all cylinders) thoroughly. Excessive wear and even mechanical damage to pins and cylinders can result from inadequate lubrication. Use a multi-purpose grease.

Lubricate all grease fittings with a multi-purpose grease. For grease locations, refer to the diagram in the lubrication section of this manual.

EVERY 40 HOURS OF OPERATION

Check hydraulic reservoir fluid level. If oil is low, check all lines, fittings, and control valve for signs of leakage.

IMPORTANT: Hydraulic fluid level should be checked with backhoe in transport position.

WARNING! Escaping hydraulic/diesel fluid under pressure can penetrate the skin causing serious injury.



DO NOT use your hand to check for leaks. Use a piece of cardboard or paper to search for leaks.

Stop engine and relieve pressure before connecting or disconnecting lines.

Tighten all connections before starting engine or pressurizing lines.

If any hydraulic/diesel fluid is injected into the skin, obtain medical attention immediately or gangrene or other serious injury will result.

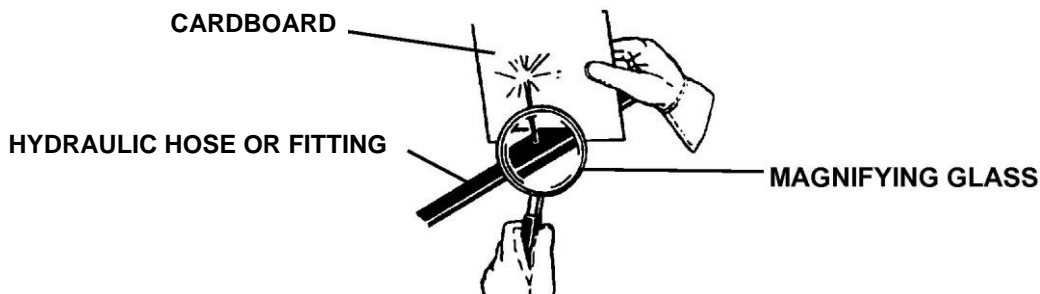

Physically check all pins, bushings, cotter pins, nuts, etc., for signs of wear or loose fit. Tighten as required, replacing where necessary. (Bolts and pins may vibrate loose during operation.) Clean equipment of all dirt, oil, and excess grease. This will assist you in making visual inspections and help avoid overlooking worn or damaged components.

MAINTENANCE AND SERVICE

CONTROL VALVE

The hydraulic control valve maintenance is normally limited to replacement of O-ring seals, cleaning and the replacement of relief valve cartridges.

The most common cause of premature wear and malfunctioning of hydraulic system components is the ingress of contaminants and incorrect high pressure inlet and low pressure return connections (cavitation).

Observe a high standard of cleanliness when doing valve maintenance.

REPLACING BUCKET TEETH

The bucket teeth are self-sharpening and require little attention: however, they can be replaced when they become worn or broken.

Remove the two capscrews and lock nuts securing the tooth to the bucket and replace with new bucket teeth and hardware .

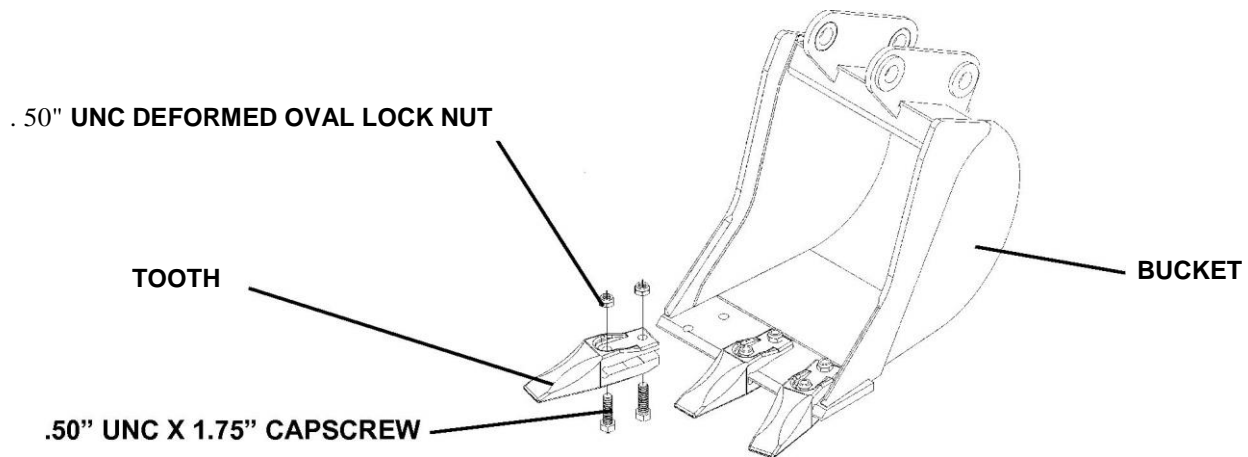

CHANGING BUCKETS

The bucket is connected to the dipper and bucket link with snap ring style pins. To change buckets, remove the snap rings and washers from one side of the pivot pins, slide the pins out and then remove the old bucket. Position the new bucket in its place. Install the pivot pins and secure with snap rings and thrust washers. Lubricate both pivot pin grease fittings before operating.

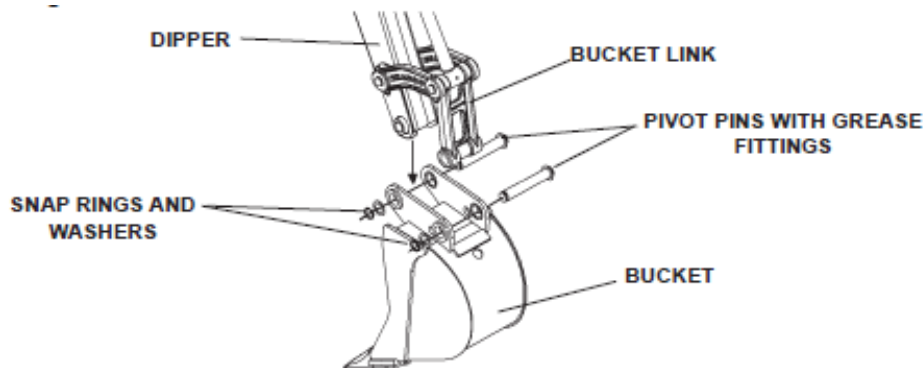

MAINTENANCE AND SERVICE

HOSE ROUTING

20.

GENERAL INFORMATION

The purpose of this page is to show the hydraulic hose routing between the backhoe control valve and the various backhoe hydraulic cylinders. This information is helpful when trouble shooting cylinder and control valve related problems. Simply match the number of the hydraulic cylinder port (shown in the bottom diagram), to the corresponding number on the backhoe control valve (shown in the top diagram).

BACKHOE CONTROL VALVE

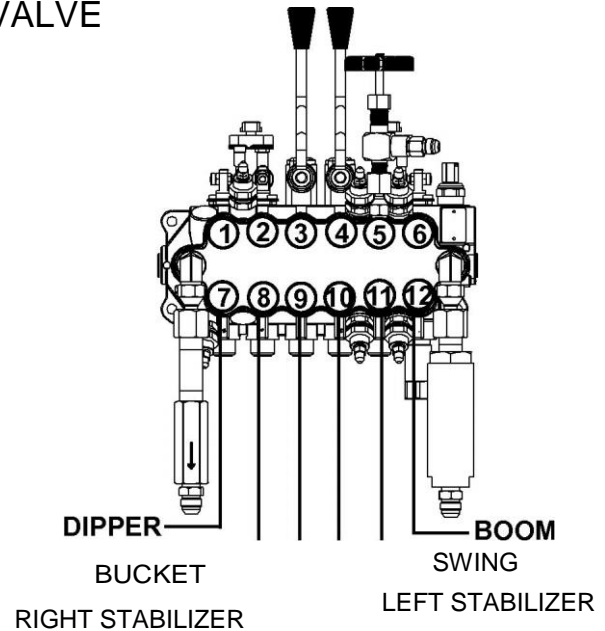

BACKHOE CYLINDERS

NOTE: The fittings on the hydraulic cylinders have been altered for clarity purposes. This will assist you in distinguishing between the rod end and the barrel end of the various hydraulic cylinders.

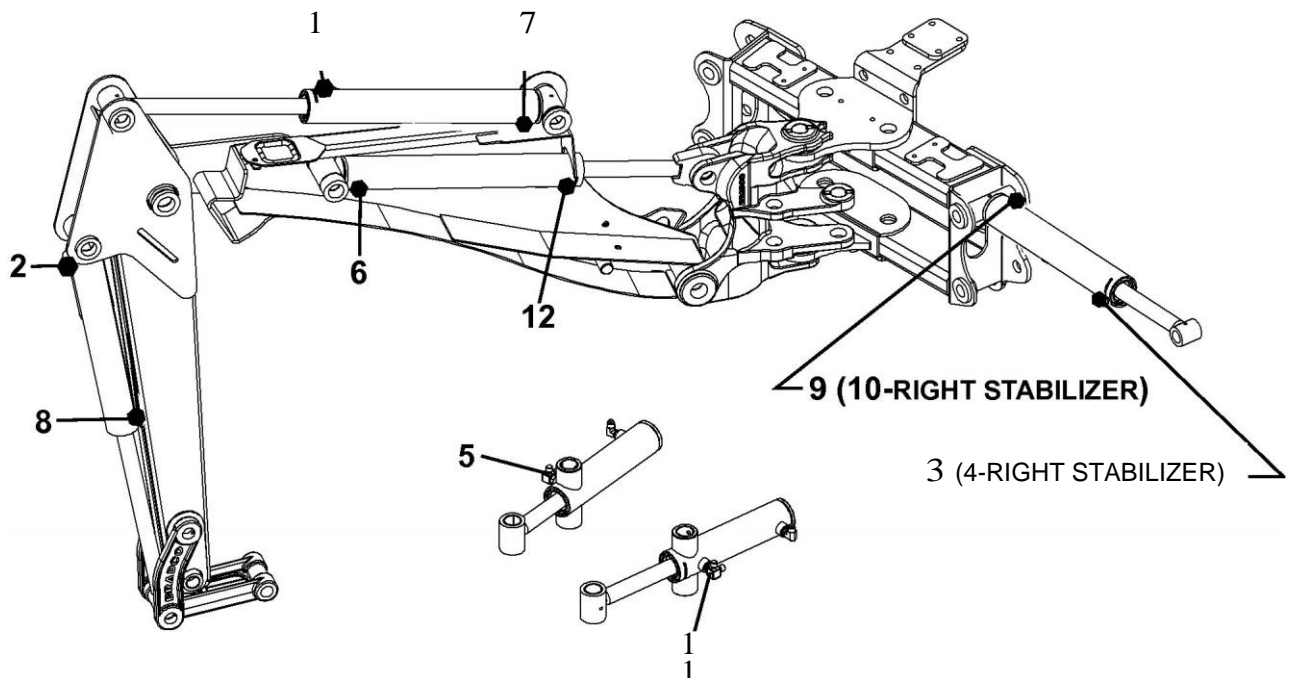

MAINTENANCE AND SERVICE

CYLINDER SEAL REPLACEMENT

The following information is provided to assist you in the event you should need to repair or rebuild a hydraulic cylinder. When working on hydraulic cylinders, make sure that the work area and tools are clean and free of dirt to prevent contamination of the hydraulic system and damage to the hydraulic cylinders. Always protect the active part of the cylinder rod (the chrome section). Nicks or scratches on the surface of the rod could result in cylinder failure. Clean all parts thoroughly with a cleaning solvent before reassembly.

DISASSEMBLY PROCEDURE

IMPORTANT: Do not contact the active surface of the cylinder rod with the vise. Damage to the rod could result.

RETAINING RING TYPE GLAND

1. Mount the cylinder tube securely in a vise. **NOTICE:** Do not clamp too tight and distort the tube.
2. Rotate the gland with a spanner wrench (available from your dealer), until the gland retaining ring appears in the milled slot.

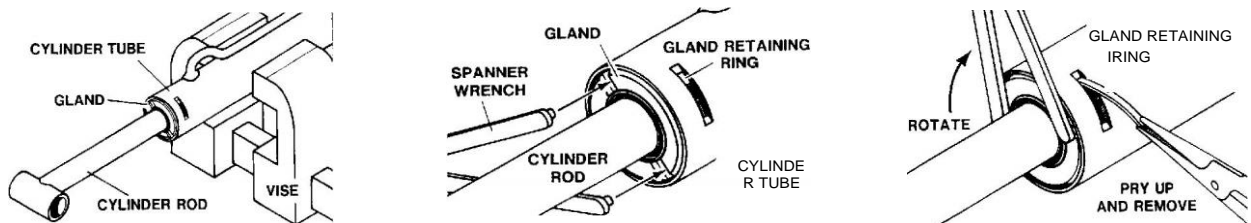

Pry up the end of the gland retaining ring with a pointed tool. Rotate the gland with a spanner wrench while removing the retaining ring. **NOTE:** The gland and piston seal(s) can be pulled out and cut as they appear in the milled slot during disassembly. After cutting, pull them out through the milled slot.

3. Pull the cylinder rod from the cylinder tube.



4. Inspect the piston and the bore of the cylinder tube for deep scratches or galling. If damaged, the piston and cylinder tube must be replaced.
5. Remove the hex nut, piston, flat washer or spacer tube (if so equipped), and gland from the cylinder rod. If the cylinder rod is rusty, scratched, or bent, it must be replaced.
6. Remove and discard all old seals.

ASSEMBLY PROCEDURE

IMPORTANT: Replace all seals even if they do not appear to be damaged. Failure to replace all seals may result in premature cylinder failure.

1. Install the cylinder rod seal in the gland first. Be careful not to damage the seal in the process as it is somewhat difficult to install. A special installation tool is available to help with installing the seal. Simply fit the end of the tool over the seal so that the large prong of the tool is on the outside of the seal, and the two smaller prongs on the inside. The lip of the seal should be facing towards the tool. Rotate the handles on the tool around to wrap the seal around the end of the tool.

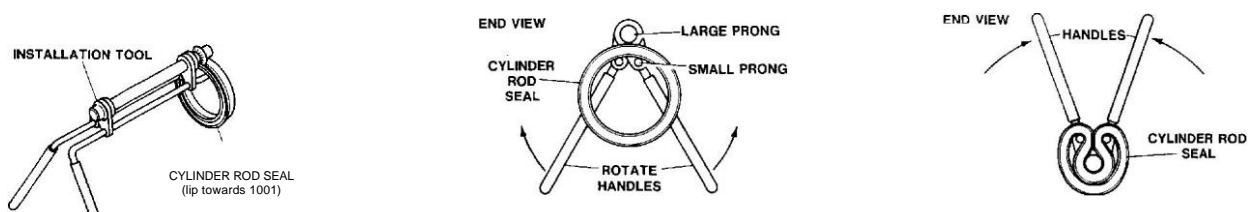

10530 3-8-06

MAINTENANCE AND SERVICE

Now insert the seal into the gland from the inner end. Position the seal in its groove, and release and remove the tool. Press the seal into its seat the rest of the way by hand.

NOTE: Threaded gland is shown in diagram for reference only.

- Install the new piston ring, rod wiper, O-rings, and backup washers, if applicable, on the piston. Be careful not to damage the seals. Caution must be used when installing the piston ring. The ring must be stretched carefully over the piston with a smooth, round, pointed tool.
- Slide the gland onto the cylinder rod being careful not to damage the rod wiper. Then install the spacer, or flat washer (if so equipped), small O-ring, piston, and hex nut onto the end of the cylinder rod.
- Secure the cylinder rod (mounting end) in a vise, with a support at its center. Torque the nut to the amount shown on the chart for the thread diameter of the cylinder rod. (see chart)

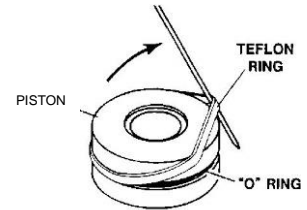
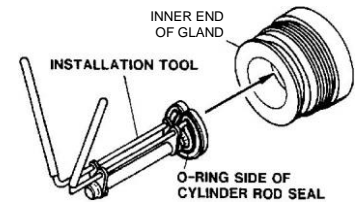

Thread Diameter	POUNDS - FEET
7/8"	150-200
*1"	230-325
1-1/8"	350-480
1-1/4"	490-670
1-3/8"	670-900

* 1" Thread Diameter WITH 1.25" Rod Diameter
 Min. 230 ft. lbs. Max. 250 ft. lbs.

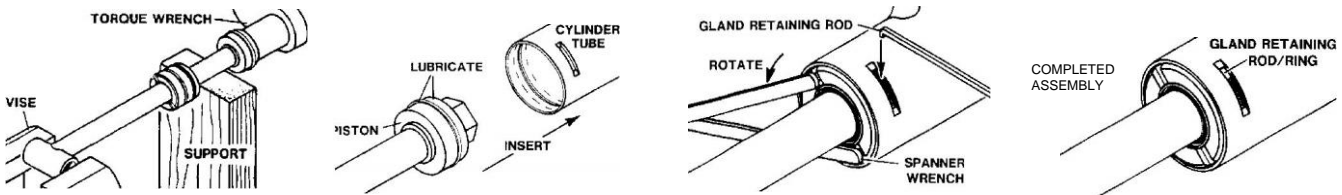

IMPORTANT: Do not contact the active surface of the cylinder rod with the vise. Damage to the rod could result.

IMPORTANT: Ensure that the piston ring fits squarely into the cylinder tube and piston groove, otherwise the ring may be damaged and a leak will occur.

- Apply a lubricant (such as Lubriplate #105) to the piston and teflon ring. Insert the cylinder rod assembly into the cylinder tube.
- Rotate the gland with a spanner wrench until the hole (drilled into the retaining slot of the gland) appears in the milled slot of the cylinder tube. Insert the hooked end of the gland retaining rod into the hole.

Rotate the gland until the gland retaining rod forms a ring between the gland and the cylinder tube. When complete, the bent end of the gland retainer ring should be hidden (not turned so it is exposed in the slot) to prevent it from popping out.

WARNING!



Cylinders serviced in the field are to be tested for leakage prior to the attachment being placed in work. Failure to test rebuilt cylinders could result in damage to the cylinder and/or the attachment, cause severe personal injury or even death.

TROUBLESHOOTING

PROBLEM	POSSIBLE CAUSE	REMEDY
Backhoe fails to lift or swing	Low oil supply	Add oil
	Swing speed control completely closed	Open swing speed control valve
	Improper hose hookup	Check hydraulic diagram; reinstall properly
	Broken hydraulic line	Check for leaks and replace line
	Jammed swing linkage	Remove interference
	Bent cylinder rod	Replace or repair cylinder
Backhoe lifting or swinging too slowly	Swing speed control completely closed	Open swing speed control valve
	Cold oil	Warm oil with engine at idle speed
	Engine speed too slow	Open throttle
	Oil too heavy	Use recommended oil
	Oil leaking past cylinder packings	Replace packings
	Dirty oil filter	Replace filter
	Faulty relief valve	Clean or replace
Incorrect restrictors in valve	Check restrictor orifice size with those shown on valve assembly page	
Backhoe fails to hold up load	Broken or leaking lines	Replace broken hose and check for leaks
	Dirty oil	Drain and refill oil, replace filter
	Oil leaking past cylinder packings	Replace packings
	Faulty relief valve	Clean or replace

TROUBLESHOOTING

PROBLEM	POSSIBLE CAUSE	REMEDY
Oil heating	Dirty oil	Drain and refill oil, replace filter
	Partially plugged inlet filter	Clean filter element
	Control valve held open too long	Return control to neutral position when not in use
	Relief valve set too low	Set valve correctly
	Oil too light in hot weather	Use recommended oil
	Engine running too fast	Reduce throttle
	Damaged oil lines	Replace damaged lines
	Poor operating technique causing excessive oil flow over relief valve	Learn smooth operating methods
External leakage	Damaged a-rings on valve spools	Repair control valve
	Cylinder seals damaged	Repair cylinder
	Broken oil lines	Replace hose and check for leaks
Swing cylinder malfunctioning	Oil leaking past packing or seals	Replace packing or seals
	Faulty relief valve	Clean or replace

TROUBLESHOOTING

PROBLEM	POSSIBLE CAUSE	REMEDY
Control valve sticking or working hard	Dirty valve	Clean valve
	Scored bore or bent spool	Inspect and replace spool, or entire valve
	Control linkage misaligned	Correct misalignment
	Return spring binding broken	Replace spring
	Foreign matter in spool bore	Clean valve
	Displaced O'rings in valve	Replace O'rings
	Excessive oil flow	Check flow rate. If over 12 GPM Contact Factory



BOLT TORQUE

BOLT TORQUE SPECIFICATIONS

GENERAL TORQUE SPECIFICATION TABLE

Use the following torques when special torques are not given. These values apply to fasteners as received from suppliers, dry, or when lubricated with normal engine oil. They do not apply if special graphited or moly disulphide greases or other extreme pressure lubricants are used. This applies to both UNF and UNC threads. Remember to always use grade five or better when replacing bolts.

IMPORTANT: On all PLATED GRADE 8 bolts, reduce torque 15 from listed bolt torque specification.

SAE Grade No.		2				5				8*			
Bolt head identification marks as per grade. NOTE: Manufacturing Marks Will Vary													
		TORQUE		TORQUE		TORQUE		TORQUE		TORQUE		TORQUE	
Bolt Size Inches	Millimeters	Pounds Feet	Newton-Meters	Pounds Feet	Newton-Meters	Pounds Feet	Newton-Meters	Pounds Feet	Newton-Meters	Pounds Feet	Newton-Meters	Pounds Feet	Newton-Meters
		Min.	Max.	Min.	Max.	Min.	Max.	Min.	Max.	Min.	Max.	Min.	Max.
1/4	6.35	5	6	7	8	9	11	12	15	12	15	16	20
5/16	7.94	10	12	14	16	17	20.5	23	28	24	29	33	39
3/8	9.53	20	23	27	31	35	42	48	57	45	54	61	73
7/16	11.11	30	35	41	47	54	64	73	87	70	84	95	114
1/2	12.70	45	52	61	70	80	96	109	130	110	132	149	179
9/16	14.29	65	75	88	102	110	132	149	179	160	192	217	260
5/8	15.88	95	105	129	142	150	180	203	244	220	264	298	358
3/4	19.05	150	185	203	251	270	324	366	439	380	456	515	618
7/8	22.23	160	200	217	271	400	480	542	651	600	720	814	976
1	25.40	250	300	339	406	580	696	787	944	900	1080	1220	1464
1-1/8	25.58	-	-	-	-	800	880	1085	1193	1280	1440	1736	1953
1-1/4	31.75	-	-	-	-	1120	1240	1519	1681	1820	2000	2468	2712
1-3/8	34.93	-	-	-	-	1460	1680	1980	2278	2380	2720	3227	3688
1-1/2	38.10	-	-	-	-	1940	2200	2631	2983	3160	3560	4285	4827

* Thick Nuts must be used with Grade 8 bolts

METRIC BOLT TORQUE SPECIFICATIONS

Size of Screw	Grade No.	Coarse Thread			Fine Thread		
		Pitch (mm)	Pounds Feet	Newton-Meters	Pitch (mm)	Pounds Feet	Newton-Meters
M6	5.6	1.0	3.6-5.8	4.9-7.9	-	-	-
	8.8		5.8-4	7.9-12.7		-	-
	10.9		7.2-10	9.8-13.6		-	-
M8	5.6	1.25	7.2-14	9.8-19	1.0	12-17	16.3-23
	8.8		17-22	23-29.8		19-27	25.7-36.6
	10.9		20-26	27.1-35.2		22-31	29.8-42
M10	5.6	1.5	20-25	27.1-33.9	1.25	20-29	27.1-39.3
	8.8		34-40	46.1-54.2		35-47	47.4-63.7
	10.9		38-46	51.5-62.3		40-52	54.2-70.5
M12	5.6	1.75	28-34	37.9-46.1	1.25	31-41	42-55.6
	8.8		51-59	69.1-79.9		56-68	75.9-92.1
	10.9		57-66	77.2-89.4		62-75	84-101.6
M14	5.6	2.0	49-56	66.4-75.9	1.5	52-64	70.5-86.7
	8.8		81-93	109.8-126		90-106	122-143.6
	10.9		96-109	130.1-147.7		107-124	145-168
M16	5.6	2.0	67-77	90.8-104.3	1.5	69-83	93.5-112.5
	8.8		116-130	157.2-176.2		120-138	162.6-187
	10.9		129-145	174.8-196.5		140-158	189.7-214.1
M18	5.6	2.0	88-100	119.2-136	1.5	100-117	136-158.5
	8.8		150-168	203.3-227.6		177-199	239.8-269.6
	10.9		175-194	237.1-262.9		202-231	273.7-313
M20	5.6	2.5	108-130	146.3-176.2	1.5	132-150	178.9-203.3
	8.8		186-205	252-277.8		206-242	279.1-327.9
	10.9		213-249	288.6-337.4		246-289	333.3-391.6

SPECIFICATIONS

365 BACKHOE

29.

BACKHOE DIMENSIONS

SPECIFICATIONS AND DESIGN ARE SUBJECT TO CHANGE WITHOUT NOTICE AND WITHOUT LIABILITY THEREFORE. WHENEVER APPLICABLE SPECIFICATIONS ARE IN ACCORDANCE WITH SAE STANDARDS.

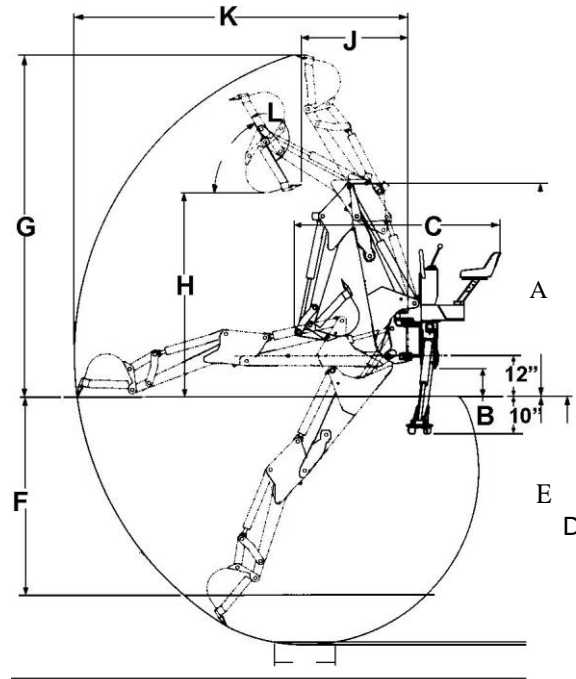

DESCRIPTION

365

TRANSPORT

A Transport Height (with boom fully retracted)	67"
Transport Width (with stabilizers up)45"
B Ground Clearance	9.5"
C Overall Length	76"
Boom Pivot Height	12"
Operating Weight w/12" Bucket	712#

OPERATIONAL

D Digging Depth Maximum	78"
E Digging Depth (2 Ft.) Flat Bottom	76"
F Digging Depth (8 Ft.) Flat Bottom	52"
G Overall Operating Height - Fully Raised	108"
H Loading Height	55"
J Loading Reach	46"
K Reach From Swing Post	108"
L Bucket Rotation	180°
Swing Arc	180°
Stabilizer Spread Operating Position	87"
Stabilizer Down Below Grade	10"
System Relief Valve Setting	2250 PSI
Digging Force - Bucket Cylinder	2599#
Digging Force - Dipper Cylinder	1358#

10669 8-11-06

SPECIFICATIONS

365 BACKHOE

CYLINDER SPECIFICATION TABLE

CYLINDER	SPECIFICATION
BUCKET CYLINDER	
Cylinder #	103687
Bore	2.25"
Stroke	14.35"
Rod Diameter	1 .25"
DIPPER CYLINDER	
Cylinder #	103677
Bore	2.25"
Stroke	15.47"
Rod Diameter	1 .25"
BOOM CYLINDER	
Cylinder #	103669
Bore	2.25"
Stroke	15.98"
Rod Diameter	1 .25"
SWING CYLINDER	
Cylinder #	103661
Bore	2.25"
Stroke	7.06"
Rod Diameter	1 .25"
STABILIZER CYLINDER	
Cylinder #	103649
Bore	2.25"
Stroke	12.06"
Rod Diameter	1 .25"

BUCKETS AND CAPACITIES

Bucket <u>Size</u>	<u>Heaped</u> Cal2. Ft. ³	<u>Weight</u> <u>Lbs.</u>	Number Of Teeth
8"	.61	40	2
10"	.85	43	3
12"	1.09	47	3
16"	1.54	60	4
18"	2.78	63	4

**THIS PAGE
IS INTENTIONALLY
BLANK**

BACKHOE CHECKLIST

FOR USE WITH BACKHOES AND BACKHOE MOUNTING KITS

DEALER RESPONSIBILITY:

The following check list is to be completed by the equipment dealer. This checklist is to be completed by the dealer at time of delivery. When purchasing a mounting kit for an existing backhoe it is the equipment dealers responsibility to review this checklist with the customer and instruct them to check each item at time of installation onto their prime mover.

BACKHOE:

1. Check and lubricate backhoe. See "Lubrication Section" in Operator's Manual.
- . Visually inspect the backhoe for bent, loose, cracked, damaged or missing parts or any other irregularities prior to operation.
2. Verify backhoe control lever function and direction of operation are in accordance with the control lever decals.
3. Run cylinders through their full cycle to purge any air from the system. Recheck hydraulic system for correct hydraulic fluid levels.
4. Check all hydraulic connections for leaks and all hoses for proper positioning to reduce chafing and binding.
5. Check prime mover system relief valve pressure and compare and adjust to recommend operating pressure listed in the "Specifications Section" of the Operator's Manual.
6. Make sure decals are not damaged or missing and are in their right location. See "Decals Section" of the Operator's Manual.
7. Customer instructed to read and understand Operator's Manual before operating backhoe.
Complete and return the manufacturers "Warranty Validation Form".

8.
.
9.
.

MOUNTING:

1. Check backhoe, mounting, and prime mover to ensure they are all compatible.
- . Check backhoe mounting bolts for tightness. Instruct owner to retighten after the first eight working hours, and after every forty working hour interval thereafter. See "Bolt Torque Specifications" in Operator's Manual.
2. If customer is installing the mounts and mounting the backhoe to the prime mover, the dealer must review the proper mounting procedure and possible consequences of improper installation.
3. Verify the owner is in possession of an operator's manual and instruct them to read and understand all safety and operating techniques.
- 4.

OWNERS RESPONSIBILITY:

It is the owner's responsibility to make sure that the dealer has completed this checklist and instructed him/her on safe and proper operation of the backhoe. If installation instructions are unclear, bring backhoe, mounting and prime mover to the equipment dealership for proper installation.

Owner's Signature

Date

Dealership Signature

Date

**THIS PAGE
IS INTENTIONALLY
BLANK**

Limited Warranty

Except for the Excluded Products as described below, all new products are warranted to be free from defects in material and/or workmanship during the Warranty Period, in accordance with and subject to the terms and conditions of this Limited Warranty.

1. Excluded Products. The following products are excluded from this Limited Warranty:

(a) Any cable, part that engages with the ground (i.e. sprockets), digging chain, bearing, teeth, tamping and/or demolition head, blade cutting edge, pilot bit, auger teeth and broom brush that either constitutes or is part of a product.

(b) Any product, merchandise or component that, in the opinion of Spartan Equipment', has been (i) misused; (ii) modified in any unauthorized manner; (iii) altered; (iv) damaged; (v) involved in an accident; or (vi) repaired using parts not obtained through Spartan Equipment.

2. Warranty Period. The Limited Warranty is provided only to those defects that occur during the Warranty Period, which is the period that begins on the first to occur of: (i) the date of initial purchase by an end-user, (ii) the date the product is first leased or rented, or (iii) the date that is six (6) months after the date of shipment by Spartan Equipment as evidenced by the invoiced shipment date (the "Commencement Date") and ends on the date that is twenty-four (24) months after the Commencement Date.

3. Terms and Conditions of Limited Warranty. The following terms and conditions apply to the Limited Warranty hereby provided:

(a) Option to Repair or Replace. Spartan Equipment shall have the option to repair or replace the product.

(b) Timely Repair and Notice. In order to obtain the Limited Warranty, (i) the product must be repaired within thirty (30) days from the date of failure, and (ii) a claim under the warranty must be submitted to Spartan Equipment in writing within thirty (30) days from the date of repair.

(c) Return of Defective Part or Product. If requested by Spartan Equipment, the alleged defective part or product shall be shipped to Spartan Equipment at its manufacturing facility or other location specified by Spartan Equipment, with freight PRE-PAID by the claimant, to allow Spartan Equipment to inspect the part or product.

Claims that fail to comply with any of the above terms and conditions shall be denied.

LIMITATIONS AND EXCLUSIONS.

THIS LIMITED WARRANTY IS IN LIEU OF ALL OTHER WARRANTIES, EXPRESS OR IMPLIED, INCLUDING WITHOUT LIMITATION THE WARRANTIES OF MERCHANTABILITY, FITNESS FOR A PARTICULAR PURPOSE AND ANY WARRANTY BASED ON A COURSE OF DEALING OR USAGE OF TRADE.

IN NO EVENT SHALL SPARTAN EQUIPMENT BE LIABLE FOR CONSEQUENTIAL OR SPECIAL DAMAGES.

IN NO EVENT SHALL SPARTAN EQUIPMENT BE LIABLE FOR ANY LOSS OR CLAIM IN AN AMOUNT IN EXCESS OF THE PURCHASE PRICE, OR, AT THE OPTION OF SPARTAN EQUIPMENT, THE REPAIR OR REPLACEMENT, OF THE PARTICULAR PRODUCT ON WHICH ANY CLAIM OF LOSS OR DAMAGE IS BASED. THIS LIMITATION OF LIABILITY APPLIES IRRESPECTIVE OF WHETHER THE CLAIM IS BASED ON BREACH OF CONTRACT, BREACH OF WARRANTY, NEGLIGENCE OR OTHER CAUSE AND WHETHER THE ALLEGED DEFECT IS DISCOVERABLE OR LATENT.