

OPERATOR'S MANUAL

INDUSTRIAL GRAPPLE RAKE

FOR
SKID STEER LOADERS

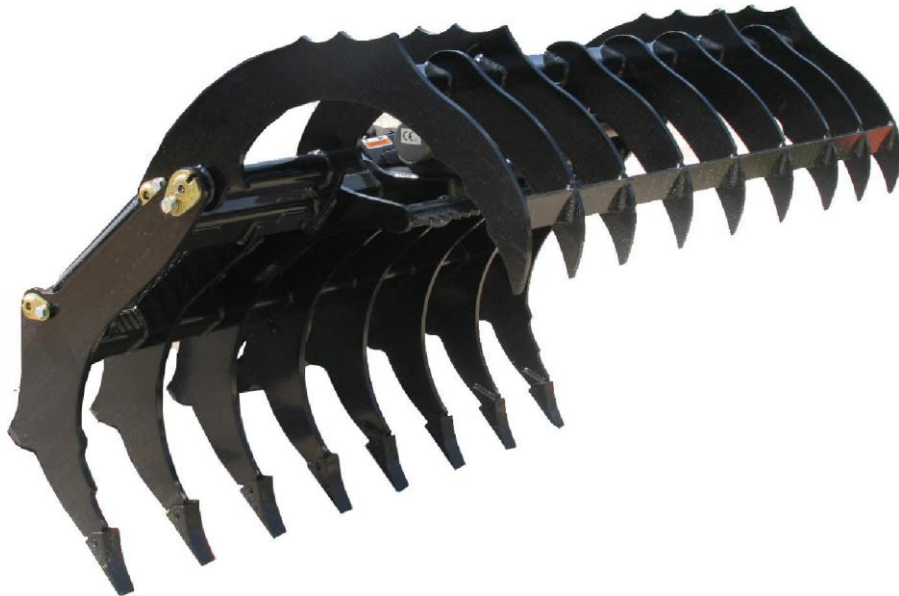

SERIAL NUMBER:

MODEL NUMBER:

Manual Number: PM711

Part Number: 75611

Rev. 6

TABLE OF CONTENTS

PREFACE	3
SAFETY PRECAUTIONS	
SAFETY STATEMENTS	5
GENERAL SAFETY PRECAUTIONS	5-7
EQUIPMENT SAFETY PRECAUTIONS	8-9
DECALS	
DECAL PLACEMENT	10
DECALS	11
INSTALLATION AND OPERATION	
INSTALLATION	12
DETACHING	12
INTENDED USE	12
OPERATION	12-13
STORAGE	13
LIFT POINTS	14
TIE DOWN POINTS	14
TRANSPORTING	14
MAINTENANCE AND SERVICE	
ROUTINE MAINTENANCE	15
CYLINDER SEAL REPLACEMENT	16-17
SPECIFICATIONS	
BOLT TORQUE SPECIFICATIONS	18
ROOT RAKE SPECIFICATIONS	19
PARTS / LIMITED WARRANTY	20

**THIS PAGE
IS INTENTIONALLY
BLANK**

PREFACE

GENERAL COMMENTS

Congratulations on the purchase of your new SPARTAN EQUIPMENT product! This product was carefully designed and manufactured to give you many years of dependable service. Only minor maintenance (such as cleaning and lubricating) is required to keep it in top working condition. Be sure to observe all maintenance procedures and safety precautions in this manual and on any safety decals located on the product and on any equipment on which the attachment is mounted.

This manual has been designed to help you do a better, safer job. Read this manual carefully and become familiar with its contents.

WARNING! Never let anyone operate this unit without reading the "Safety Precautions" and "Operating Instructions" sections of this manual.



Always choose hard, level ground to park the vehicle on and set the brake so the unit cannot roll.

Unless noted otherwise, right and left sides are determined from the operator's control position when facing forward.

NOTE: The illustrations and data used in this manual were current (according to the information available to us) at the time of printing, however, we reserve the right to redesign and change the attachment as may be necessary without notification.

BEFORE OPERATION

The primary responsibility for safety with this equipment falls to the operator. Make sure the equipment is operated only by trained individuals that have read and understand this manual. If there is any portion of this manual or function you do not understand, contact your local authorized dealer or the manufacturer to obtain further assistance. Keep this manual available for reference. Provide the manual to any new owners and/or operators.

SAFETY ALERT SYMBOL



This is the "Safety Alert Symbol" used by this industry. This symbol is used to warn of possible injury. Be sure to read all warnings carefully. They are included for your safety and for the safety of others working with you.

SERVICE

Use only manufacturer replacement parts. Substitute parts may not meet the required standards.

Record the model and serial number of your unit on the cover of this manual. The parts department needs this information to insure that you receive the correct parts.

SOUND AND VIBRATION

Sound pressure levels and vibration data for this attachment are influenced by many different parameters: some items are listed below (not inclusive):

- prime mover type, age, condition, with or without cab enclosure and configuration
- operator training, behavior, stress level
- job site organization, working material condition, environment

Based on the uncertainty of the prime mover, operator, and job site, it is not possible to get precise machine and operator sound pressure levels or vibration levels for this attachment.

**THIS PAGE
IS INTENTIONALLY
BLANK**

SAFETY STATEMENTS



THIS SYMBOL BY ITSELF OR WITH A WARNING WORD THROUGHOUT THIS MANUAL IS USED TO CALL YOUR ATTENTION TO INSTRUCTIONS INVOLVING YOUR PERSONAL SAFETY OR THE SAFETY OF OTHERS. FAILURE TO FOLLOW THESE INSTRUCTIONS CAN RESULT IN INJURY OR DEATH.



DANGER! THIS SIGNAL WORD INDICATES A HAZARDOUS SITUATION WHICH, IF NOT AVOIDED, WILL RESULT IN DEATH OR SERIOUS INJURY.



WARNING! THIS SIGNAL WORD INDICATES A HAZARDOUS SITUATION WHICH, IF NOT AVOIDED, COULD RESULT IN DEATH OR SERIOUS INJURY.



CAUTION! THIS SIGNAL WORD INDICATES A HAZARDOUS SITUATION WHICH, IF NOT AVOIDED, COULD RESULT IN MINOR OR MODERATE INJURY.

NOTICE

NOTICE IS USED TO ADDRESS PRACTICES NOT RELATED TO PHYSICAL INJURY.

GENERAL SAFETY PRECAUTIONS

WARNING!

READ MANUAL PRIOR TO INSTALLATION



Improper installation, operation, or maintenance of this equipment could result in serious injury or death. Operators and maintenance personnel should read this manual, as well as all manuals related to this equipment and the prime mover thoroughly before beginning installation, operation, or maintenance. **FOLLOW ALL SAFETY INSTRUCTIONS IN THIS MANUAL AND THE PRIME MOVER'S MANUAL(S).**

READ AND UNDERSTAND ALL SAFETY STATEMENTS



Read all safety decals and safety statements in all manuals prior to operating or working on this equipment. Know and obey all OSHA regulations, local laws, and other professional guidelines for your operation. Know and follow good work practices when assembling, maintaining, repairing, mounting, removing, or operating this equipment.

KNOW YOUR EQUIPMENT



Know your equipment's capabilities, dimensions, and operations before operating. Visually inspect your equipment before you start, and never operate equipment that is not in proper working order with all safety devices intact. Check all hardware to ensure it is tight. Make certain that all locking pins, latches, and connection devices are properly installed and secured. Remove and replace any damaged, fatigued, or excessively worn parts. Make certain all safety decals are in place and are legible. Keep decals clean, and replace them if they become worn or hard to read.

GENERAL SAFETY PRECAUTIONS

WARNING!



PROTECT AGAINST FLYING DEBRIS

Always wear proper safety glasses, goggles, or a face shield when driving pins in or out, or when any operation causes dust, flying debris, or any other hazardous material.

WARNING!



LOWER OR SUPPORT RAISED EQUIPMENT

Do not work under raised booms without supporting them. Do not use support material made of concrete blocks, logs, buckets, barrels, or any other material that could suddenly collapse or shift positions. Make sure support material is solid, not decayed, warped, twisted, or tapered. Lower booms to ground level or on blocks. Lower booms and attachments to the ground before leaving the cab or operator's station.

WARNING!



USE CARE WITH HYDRAULIC FLUID PRESSURE

Hydraulic fluid under pressure can penetrate the skin and cause serious injury or death. Hydraulic leaks under pressure may not be visible. Before connecting or disconnecting hydraulic hoses, read your prime mover's operator's manual for detailed instructions on connecting and disconnecting hydraulic hoses or fittings.

- Keep unprotected body parts, such as face, eyes, and arms as far away as possible from a suspected leak. Flesh injected with hydraulic fluid may develop gangrene or other permanent disabilities.
- If injured by injected fluid, see a doctor at once. If your doctor is not familiar with this type of injury, ask him to research it immediately to determine proper treatment.
- Wear safety glasses, protective clothing, and use a piece of cardboard or wood when searching for hydraulic leaks. **DO NOT USE YOUR HANDS!** SEE ILLUSTRATION.

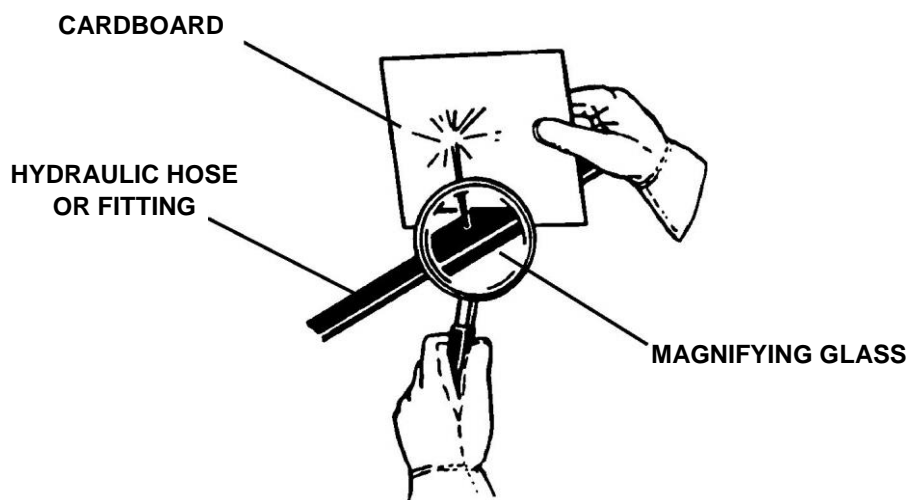

GENERAL SAFETY PRECAUTIONS

WARNING!



DO NOT MODIFY MACHINE OR ATTACHMENTS

Modifications may weaken the integrity of the attachment and may impair the function, safety, life, and performance of the attachment. When making repairs, use only the manufacturer's genuine parts, following authorized instructions. Other parts may be substandard in fit and quality. Never modify any ROPS (Roll Over Protective Structure) or FOPS (Falling Object Protective Structure) equipment or device. Any modifications must be authorized in writing by the manufacturer.

WARNING!



SAFELY MAINTAIN AND REPAIR EQUIPMENT

- Do not wear loose clothing or any accessories that can catch in moving parts. If you have long hair, cover or secure it so that it does not become entangled in the equipment.
- Work on a level surface in a well-lit area.
- Use properly grounded electrical outlets and tools.
- Use the correct tools for the job at hand. Make sure they are in good condition for the task required.
- Wear the protective equipment specified by the tool manufacturer.

SAFELY OPERATE EQUIPMENT



Do not operate equipment until you are completely trained by a qualified operator in how to use the controls, know its capabilities, dimensions, and all safety requirements. See your machine's manual for these instructions.

- Keep all step plates, grab bars, pedals, and controls free of dirt, grease, debris, and oil.
- Never allow anyone to be around the equipment when it is operating.
- Do not allow riders on the attachment or the prime mover.
- Do not operate the equipment from anywhere other than the correct operator's position.
- Never leave equipment unattended with the engine running, or with this attachment in a raised position.
- Do not alter or remove any safety feature from the prime mover or this attachment.
- Know your work site safety rules as well as traffic rules and flow. When in doubt on any safety issue, contact your supervisor or safety coordinator for an explanation.

WARNING!



CALIFORNIA PROPOSITION 65 WARNING

This product may contain a chemical known to the state of California to cause cancer, or birth defects or other reproductive harm. www.P65Warnings.ca.gov

EQUIPMENT SAFETY PRECAUTIONS

WARNING! KNOW WHERE UTILITIES ARE



Observe overhead electrical and other utility lines. Be sure equipment will clear them. When digging, call your local utilities for location of buried utility lines, gas, water, and sewer, as well as any other hazard you may encounter.

WARNING!

EXPOSURE TO RESPIRABLE CRYSTALLINE SILICA DUST ALONG WITH OTHER HAZARDOUS DUSTS MAY CAUSE SERIOUS OR FATAL RESPIRATORY DISEASE.



It is recommended to use dust suppression, dust collection and if necessary personal protective equipment during the operation of any attachment that may cause high levels of dust.

WARNING!

REMOVE PAINT BEFORE WELDING OR HEATING



Hazardous fumes/dust can be generated when paint is heated by welding, soldering or using a torch. Do all work outside or in a well ventilated area and dispose of paint and solvent properly. Remove paint before welding or heating.

When sanding or grinding paint, avoid breathing the dust. Wear an approved respirator. If you use solvent or paint stripper, remove stripper with soap and water before welding. Remove solvent or paint stripper containers and other flammable material from area. Allow fumes to disperse at least 15 minutes before welding or heating.

WARNING!

END OF LIFE DISPOSAL



At the completion of the useful life of the unit, drain all fluids and dismantle by separating the different materials (rubber, steel, plastic, etc.). Follow all federal, state and local regulations for recycling and disposal of the fluid and components.

OPERATING THE ROOT RAKE



Do not exceed the lifting capacity of your prime mover.

Operate only from the operator's station.

When operating on slopes, drive up and down, not across. Avoid steep hillside operation, which could cause the prime mover to overturn.

Reduce speed when driving over rough terrain, on a slope, or turning, to avoid overturning the vehicle.

An operator must not use drugs or alcohol, which can change his or her alertness or coordination. An operator taking prescription or over-the-counter drugs should seek medical advice on whether or not he or she can safely operate equipment.

Before exiting the prime mover, lower the attachment to the ground, turn off the prime mover's engine, remove the key and apply the brakes.

Never heap load heavy material where the combined weight of the attachment and material could exceed the rated lifting capacity of the loader.

Be sure the load does not stick out too far in front of the rake. A light load sticking out too far can have the same tipping effect as a heavy load carried in close. When using the grapple, lift the load slightly and make sure that the load is secure. If the load appears to be unstable, lower the load, open the grapple and reposition the load to attain full stability.

10675 2-14-13-2

EQUIPMENT SAFETY PRECAUTIONS

TRANSPORTING THE ROOT RAKE



Travel only with the attachment in a safe transport position to prevent uncontrolled movement. Drive slowly over rough ground and on slopes.

When driving on public roads use safety lights, reflectors, Slow Moving Vehicle signs etc., to prevent accidents. Check local government regulations that may affect you.

Do not drive close to ditches, excavations, etc., cave in could result.

Do not smoke when refueling the prime mover. Allow room in the gas tank for expansion. Wipe up any spilled fuel. Secure cap tightly when done.

MAINTAINING THE ROOT RAKE



Before performing maintenance, lower the attachment to the ground, turn off the engine, remove the key and apply the brakes.

Never perform any work on the attachment unless you are authorized and qualified to do so. Always read the operator service manual's before any repair is made.

After completing maintenance or repair, check for correct functioning of the attachment. If not functioning properly, always tag "DO NOT OPERATE" until all problems are corrected.

Worn, damaged, or illegible safety decals must be replaced. New safety decals can be ordered from SPARTAN EQUIPMENT.

Never make hydraulic repairs while the system is under pressure. Serious personal injury or death could result.

Never work under a raised attachment.

DECALS

DECAL PLACEMENT

GENERAL INFORMATION

The diagram on this page shows the location of the decals used on the Root Rake. The decals are identified by their part numbers, with reductions of the actual decals located on the following page. Use this information to order replacements for lost or damaged decals. Be sure to read all decals before operating the attachment. They contain information you need to know for both safety and product longevity.

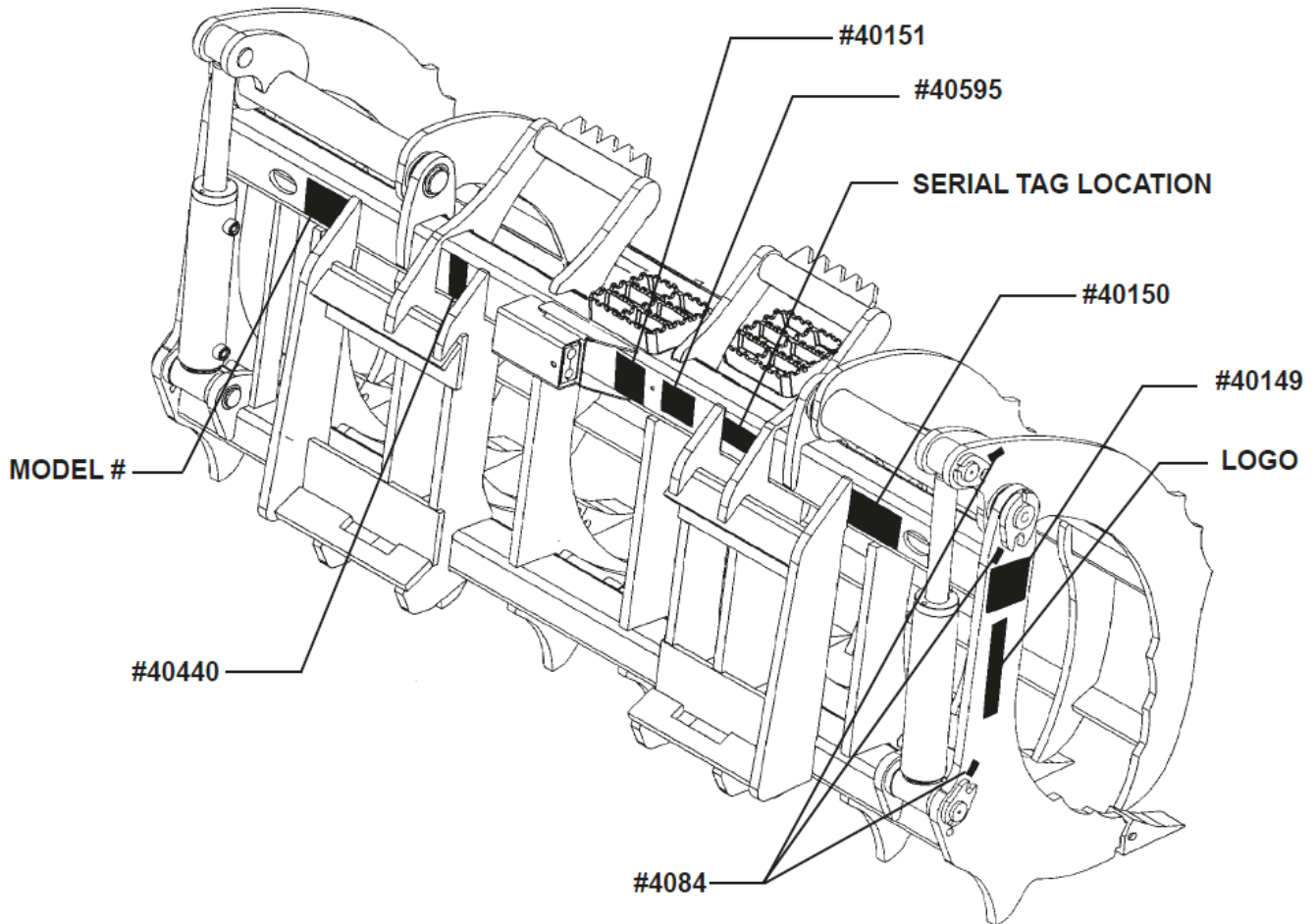

IMPORTANT: Keep all safety signs clean and legible. Replace all missing, illegible, or damaged safety signs. When replacing parts with safety signs attached, the safety signs must also be replaced.

REPLACING SAFETY SIGNS: Clean the area of application with nonflammable solvent, then wash the same area with soap and water. Allow the surface to fully dry. Remove the backing from the safety sign, exposing the adhesive surface. Apply the safety sign to the position shown in the diagram above and smooth out any bubbles.

10676 8-1-18-3

DECALS



PART #40149
DANGER! PINCH POINT

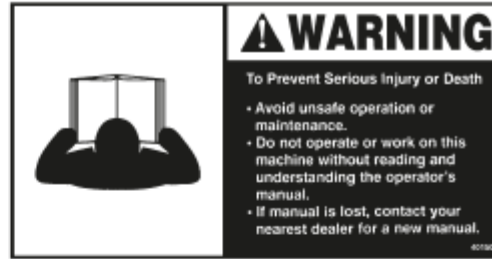

PART #40150
WARNING! READ MANUAL



PART #40595
WARNING! FALLING LOAD



PART #40151
WARNING! HIGH PRESSURE FLUID



PART #40440
WARNING! CALL BEFORE YOU DIG

NOTE: CONTACT YOUR LOCAL DEALER FOR MODEL NUMBER AND LOGO DECALS.

INSTALLATION AND OPERATION

INSTALLATION

Your Root Rake was shipped complete with the appropriate mounting for your specific unit, and with the hydraulic hoses and couplers installed.

Install the attachment by following your power unit operator's manual for installing an attachment.

WARNING!  **To Avoid Serious Personal Injury, make sure the root rake is securely latched to the attachment mechanism of your unit. Failure to do so could result in separation of the attachment from the unit.**

Connect the hydraulic quick couplers to the auxiliary hydraulics, and route the hoses in such a fashion as to prevent chafing and pinching.

Start engine and slowly cycle the cylinders several times to purge system of air and check for proper hydraulic connection, hose routing, and hose length.

Check the attachment for proper assembly, installation and hydraulic leaks.

DETACHING

On firm level ground, close the grapple and lower the boom arms completely down on the frame until the attachment is level and approximately 2" off the ground.

Turn off the engine. Move the control levers back and forth to relieve pressure in line.

Disconnect couplers.

NOTE: Connect couplers together or install caps to prevent contaminants from entering the hydraulic system.

Follow your power unit operator's manual for detaching (removing) an attachment.

NOTE: Frequent lubrication of grease fittings at the cylinder pivot pins and on each end of the grapple pins with a multi-purpose grease will greatly increase life of the product.

OPERATION

INTENDED USE: The Root Rakes are designed to pick up bulky, unusually shaped or long materials that will not stay in an ordinary bucket. In addition the Root Rakes are designed to rake large debris into a pile for easy pick up while leaving the soil and small rocks etc.

1. Approach the load in such a fashion that the weight will be centered in the grapples.
2. Close the grapples to their fullest extent possible and lift the attachment slightly to be certain that the load is secure.

NOTE: If the load appears to be unstable, lower the rake to the ground, open the grapples and reposition the load to attain full stability. Repeat until full stability is achieved.

When using the grapples as a rake to drag materials into position for pick up, **THE GRAPPLES MUST BE COMPLETELY OPEN.**

INSTALLATION AND OPERATION

NOTICE Applying a raking-type force to partially open grapples will greatly magnify the fluid pressure in the hydraulic hoses, fittings, and cylinders and may cause component failure.



Never heap load heavy material where the combined weight of the attachment and material could exceed the rated lifting capacity of the loader.

Be sure the load does not stick out too far in front of the bucket. A light load sticking out too far can have the same tipping effect as a heavy load carried in close.

Do not exceed the lift capacity of your loader. See loader specifications. When using the grapple, lift the load slightly and make sure that the load is secure. If the load appears to be unstable, lower the load, open the grapple and reposition the load to attain full stability.

Avoid side slope travel whenever possible. Drive up the slope to pick up a load and then down in reverse. Carry loads as close to the ground as possible.

Before exiting the prime mover, lower the attachment to the ground, turn off the prime mover's engine, remove the key and apply the brakes.

STORAGE

- Clean the unit thoroughly, removing all mud, dirt, and grease.
- Inspect for visible signs of wear, breakage, or damage. Order any parts required, and make the necessary repairs to avoid delays when starting next season.
- Tighten loose nuts, capscrews, and hydraulic connections.
- Seal hydraulic system from contaminants and secure all hydraulic hoses of the ground to help prevent damage.
- Lubricate grease fittings.
- Coat the exposed portions of the cylinder rods with grease.
- Replace decals that are damaged or in unreadable condition.
- Store the unit in a dry and protected place. Leaving the unit outside will materially shorten its life.

Additional Precautions for Long Term Storage:

- Touch up all unpainted surfaces with paint, to prevent rust.

REMOVAL FROM STORAGE

Remove cover.

Wash unit and replace any damaged and/or missing parts.

Lubricate grease fittings.

Check hydraulic hoses for damage and replace as necessary.

INSTALLATION AND OPERATION

LIFT POINTS

Lifting points are identified by lifting decals where required. Lifting at other points is unsafe and can damage attachment. Do not attach lifting accessories around cylinders or in any way that may damage hoses or hydraulic components. See Diagram

- Attach lifting accessories to unit at recommended lifting points.
- Bring lifting accessories together to a central lifting point.
- Lift gradually, maintaining the equilibrium of the unit.

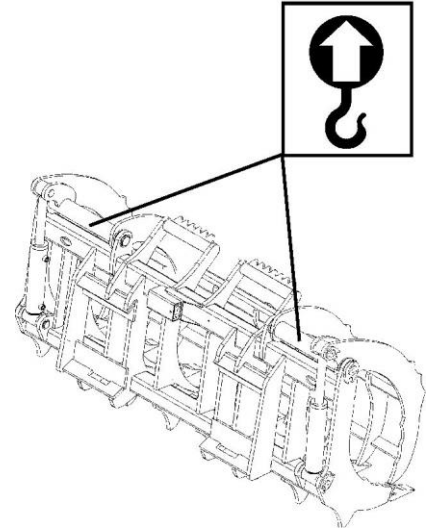

Use lifting accessories (chains, slings, ropes, shackles and etc.) that are capable of supporting the size and weight of your attachment. Secure all lifting accessories in such a way to prevent unintended disengagement. Failure to do so could result in the attachment falling and causing serious personal injury or death.

TIE DOWN POINTS

Tie down points are identified by tie down decals where required. Securing to trailer at other points is unsafe and can damage attachment. Do not attach tie down accessories around cylinders or in any way that may damage hoses or hydraulic components. See Diagram

Attach tie down accessories to unit as recommended.
Check unit stability before transporting.

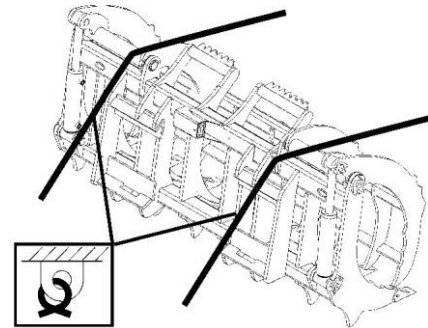

WARNING!



Verify that all tie down accessories (chains, slings, ropes, shackles and etc.) are capable of maintaining attachment stability during transporting and are attached in such a way to prevent unintended disengagement or shifting of the unit. Failure to do so could result in serious personal injury or death.

TRANSPORTING

Follow all local government regulations that may apply along with recommended tie down points and any equipment safety precautions at the front of this handbook when transporting your attachment.

MAINTENANCE AND SERVICE

GENERAL INFORMATION

Regular maintenance is the key to long equipment life and safe operation. Maintenance requirements have been reduced to an absolute minimum. However, it is very important that these maintenance functions be performed as described below.

Procedure	Daily	Every 40 Hours
Check all bolts and nuts for tightness.	✓	
Replace any missing bolts or nuts with approved replacement parts.	✓	
Check hydraulic system for hydraulic oil leaks. See procedure below.	✓	
Visually inspect the machine for worn parts or cracked welds, and repair as necessary.	✓	
Check for missing or illegible Safety / Warning Decals.	✓	
Lubricate all grease fittings.		✓

WARNING!



Escaping hydraulic / diesel fluid under pressure can penetrate the skin causing serious injury. Fluid escaping from a very small hole can be almost invisible. Use a piece of cardboard or wood, rather than hands to search for suspected leaks.

Keep unprotected body parts, such as face, eyes, and arms as far away as possible from a suspected leak. Flesh injected with hydraulic fluid may develop gangrene or other permanent disabilities. If injured by injected fluid, see a doctor at once.

Stop the engine and relieve pressure before connecting or disconnecting lines.

Tighten all connections before starting engine or pressurizing lines.

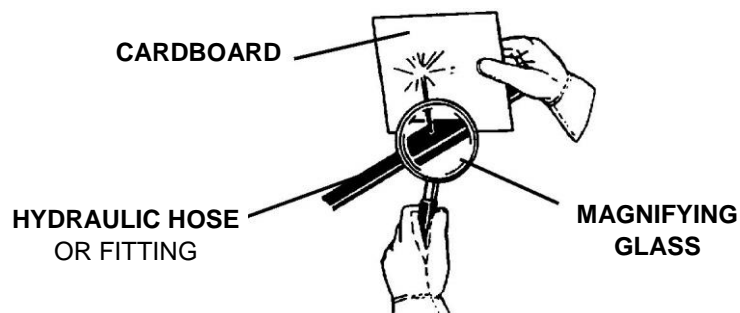

9451 2-14-13-3

MAINTENANCE AND SERVICE

6.

CYLINDER SEAL REPLACEMENT

The following information is provided to assist you in the event you should need to repair or rebuild a hydraulic cylinder. When working on hydraulic cylinders, make sure that the work area and tools are clean and free of dirt to prevent contamination of the hydraulic system and damage to the hydraulic cylinders. Always protect the active part of the cylinder rod (the chrome section). Nicks or scratches on the surface of the rod could result in cylinder failure. Clean all parts thoroughly with a cleaning solvent before reassembly.

DISASSEMBLY PROCEDURE

IMPORTANT: Do not contact the active surface of the cylinder rod with the vise. Damage to the rod could result.

THREADED TYPE GLAND

1. Rotate the gland with a spanner wrench counterclockwise until the gland is free of the cylinder tube.
2. Pull the cylinder rod from the cylinder tube and inspect the piston and the bore of the cylinder tube for deep scratches or galling. If damaged, the piston AND the cylinder tube must be replaced.

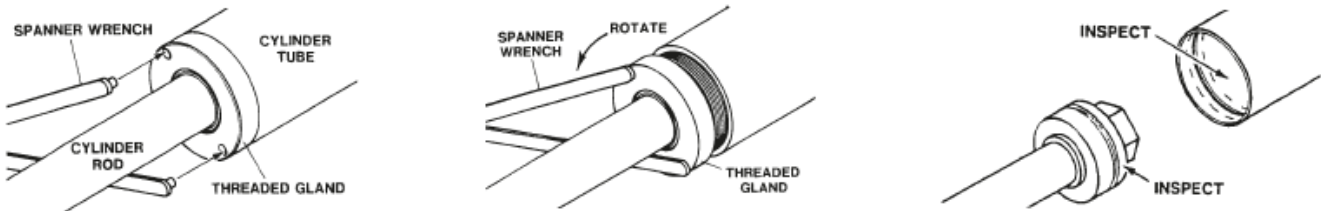

3. Remove the hex nut, piston, flat washer or spacer tube (if so equipped), and gland from the cylinder rod. If the cylinder rod is rusty, scratched, or bent, it must be replaced.
4. Remove and discard all the old seals.



ASSEMBLY PROCEDURE

IMPORTANT: Replace all seals even if they do not appear to be damaged. Failure to replace all seals may result in premature cylinder failure. NOTE: Seal kits will service most cylinders of similar bore size and rod diameter.

1. Install the cylinder rod seal in the gland first. Be careful not to damage the seal in the process, as it is somewhat difficult to install.

NOTE: A special installation tool (Part #65349) is available to help with installing the seal. Simply fit the end of the tool over the seal so that the large prong of the tool is on the outside of the seal, and the two smaller prongs on the inside. The lip of the seal should be facing towards the tool. Rotate the handles on the tool around to wrap the seal around the end of the tool.

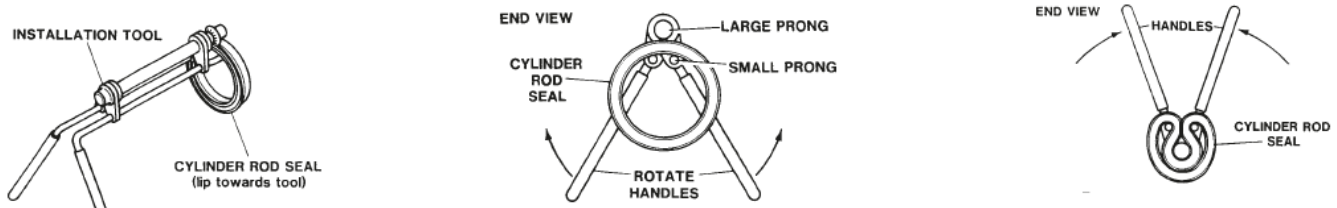

1 0356 10-13-05

MAINTENANCE AND SERVICE

8.

Now insert the seal into the gland from the inner end. Position the seal in its groove, and release and remove the tool. Press the seal into its seat the rest of the way by hand.

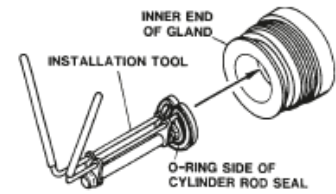

2. Install the new piston ring, rod wiper, O-rings and backup washers, if applicable, on the piston.

Be careful not to damage the seals. Caution must be used when installing the piston ring. The ring must be stretched carefully over the piston with a smooth, round, pointed tool.

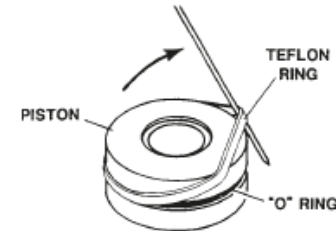

3. After installing the rod seal inside the gland, as shown in step #1, install the external seal.

NOTE: Threaded glands may have been equipped with a separate O-ring and backup washer system or a polypak (all in one) type seal. Current seal kits contain a polypak (all in one) type seal to replace the discarded seal types on ALL THREADED GLANDS.



4. Slide the gland onto the cylinder rod, being careful not to damage the rod wiper. Then install the spacer, or flat washer (if so equipped), small o-ring, piston, and hex nut onto the end of the cylinder rod.
5. Secure the cylinder rod (mounting end) in a vise with a support at its center. Torque the nut to the amount shown for the thread diameter of the cylinder rod (see chart).

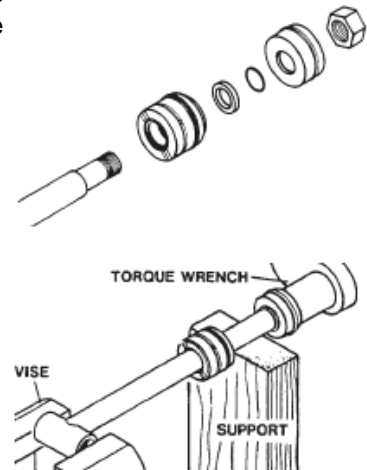

Thread Diameter	POUNDS - FEET
7/8"	150-200
*1"	230-325
1-1/8"	350-480
1-1/4"	490-670
1-3/8"	670-900

* 1" Thread Diameter WITH 1.25" Rod Diameter
 Min. 230 ft. lbs. Max. 250 ft. lbs.

IMPORTANT: Do not contact the active surface of the cylinder rod with the vise. Damage to the rod could result.

6. Apply a lubricant (such as Lubriplate #105) to the piston and teflon ring. Insert the cylinder rod assembly into the cylinder tube.

IMPORTANT: Ensure that the piston ring fits squarely into the cylinder tube and piston groove, otherwise the ring may be damaged and a leak will occur.

7. Use a spanner wrench to rotate the gland clockwise into the cylinder. Continue to rotate the gland with the spanner wrench until it is tight.

WARNING!



Cylinders serviced in the field are to be tested for leakage prior to the attachment being placed in work. Failure to test rebuilt cylinders could result in damage to the cylinder and/or the attachment, cause severe personal injury or even death.

10357 10-13-05







BOLT TORQUE

BOLT TORQUE SPECIFICATIONS

GENERAL TORQUE SPECIFICATION TABLE

Use the following torques when special torques are not given. These values apply to fasteners as received from suppliers, dry, or when lubricated with normal engine oil. They do not apply if special graphited or moly disulphide greases or other extreme pressure lubricants are used. This applies to both UNF and UNC threads. Remember to always use grade five or better when replacing bolts.

IMPORTANT: On all PLATED GRADE 8 bolts, reduce torque 15 from listed bolt torque specification.

SAE Grade No.		2				5				8*			
Bolt head identification marks as per grade. NOTE: Manufacturing Marks Will Vary						  				  			
		TORQUE		TORQUE		TORQUE		TORQUE		TORQUE		TORQUE	
Bolt Size		Pounds Feet		Newton-Meters		Pounds Feet		Newton-Meters		Pounds Feet		Newton-Meters	
Inches	Millimeters	Min.	Max.	Min.	Max.	Min.	Max.	Min.	Max.	Min.	Max.	Min.	Max.
1/4	6.35	5	6	7	8	9	11	12	15	12	15	16	20
5/16	7.94	10	12	14	16	17	20.5	23	28	24	29	33	39
3/8	9.53	20	23	27	31	35	42	48	57	45	54	61	73
7/16	11.11	30	35	41	47	54	64	73	87	70	84	95	114
1/2	12.70	45	52	61	70	80	96	109	130	110	132	149	179
9/16	14.29	65	75	88	102	110	132	149	179	160	192	217	260
5/8	15.88	95	105	129	142	150	180	203	244	220	264	298	358
3/4	19.05	150	185	203	251	270	324	366	439	380	456	515	618
7/8	22.23	160	200	217	271	400	480	542	651	600	720	814	976
1	25.40	250	300	339	406	580	696	787	944	900	1080	1220	1464
1-1/8	25.58	-	-	-	-	800	880	1085	1193	1280	1440	1736	1953
1-1/4	31.75	-	-	-	-	1120	1240	1519	1681	1820	2000	2468	2712
1-3/8	34.93	-	-	-	-	1460	1680	1980	2278	2380	2720	3227	3688
1-1/2	38.10	-	-	-	-	1940	2200	2631	2983	3160	3560	4285	4827

* Thick Nuts must be used with Grade 8 bolts

METRIC BOLT TORQUE SPECIFICATIONS

Size of Screw	Grade No.	Coarse Thread			Fine Thread		
		Pitch (mm)	Pounds Feet	Newton-Meters	Pitch (mm)	Pounds Feet	Newton-Meters
M6	5.6	1.0	3.6-5.8	4.9-7.9	-	-	-
	8.8		5.8-4	7.9-12.7		-	-
	10.9		7.2-10	9.8-13.6		-	-
M8	5.6	1.25	7.2-14	9.8-19	1.0	12-17	16.3-23
	8.8		17-22	23-29.8		19-27	25.7-36.6
	10.9		20-26	27.1-35.2		22-31	29.8-42
M10	5.6	1.5	20-25	27.1-33.9	1.25	20-29	27.1-39.3
	8.8		34-40	46.1-54.2		35-47	47.4-63.7
	10.9		38-46	51.5-62.3		40-52	54.2-70.5
M12	5.6	1.75	28-34	37.9-46.1	1.25	31-41	42-55.6
	8.8		51-59	69.1-79.9		56-68	75.9-92.1
	10.9		57-66	77.2-89.4		62-75	84-101.6
M14	5.6	2.0	49-56	66.4-75.9	1.5	52-64	70.5-86.7
	8.8		81-93	109.8-126		90-106	122-143.6
	10.9		96-109	130.1-147.7		107-124	145-168
M16	5.6	2.0	67-77	90.8-104.3	1.5	69-83	93.5-112.5
	8.8		116-130	157.2-176.2		120-138	162.6-187
	10.9		129-145	174.8-196.5		140-158	189.7-214.1
M18	5.6	2.0	88-100	119.2-136	1.5	100-117	136-158.5
	8.8		150-168	203.3-227.6		177-199	239.8-269.6
	10.9		175-194	237.1-262.9		202-231	273.7-313
M20	5.6	2.5	108-130	146.3-176.2	1.5	132-150	178.9-203.3
	8.8		186-205	252-277.8		206-242	279.1-327.9
	10.9		213-249	288.6-337.4		246-289	333.3-391.6

SPECIFICATIONS

72", 78" & 84" ROOT RAKES

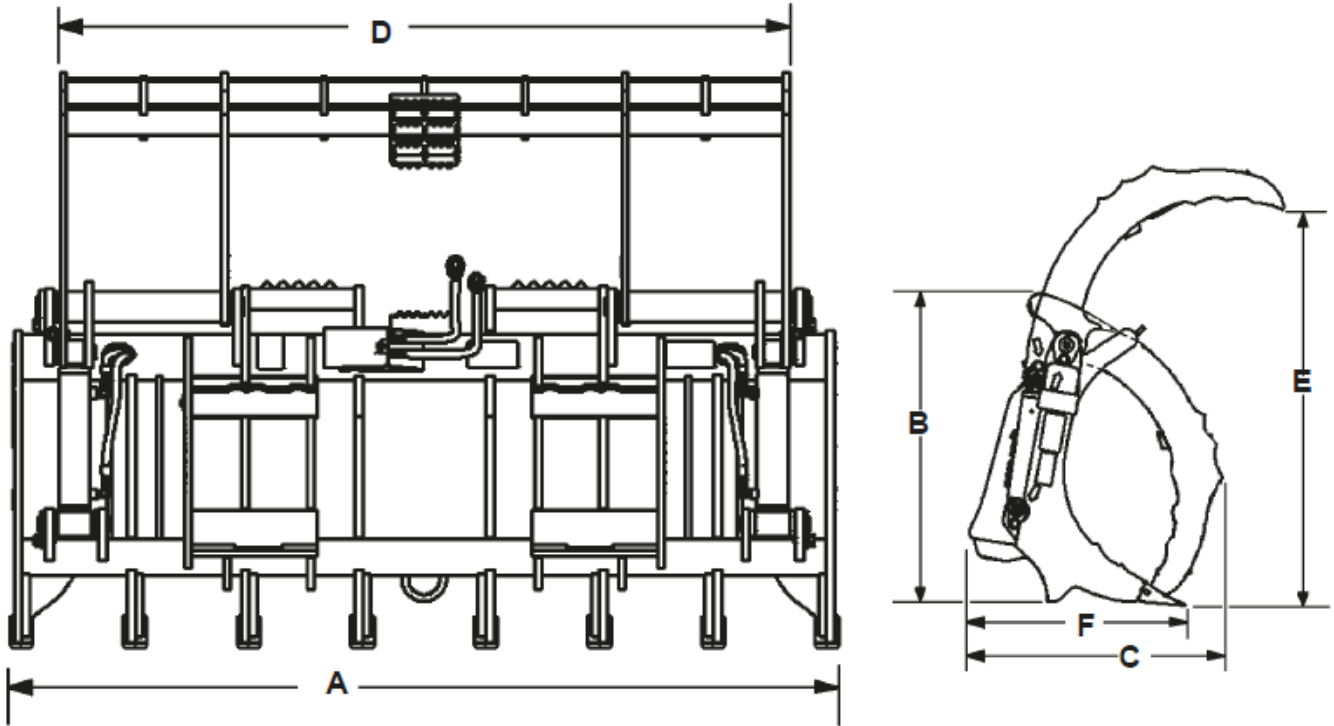

DESCRIPTION	72"	78"	84"
A. Overall Width	72.00"	78.00"	84.00"
B. Overall Height	38.90"	38.90"	38.90"
C. Overall Length	30.79"	30.79"	30.79"
D. Grapple Width	70.00"	70.00"	70.00"
E. Grapple Opening	51.00"	51.00"	51.00"
F. Tooth Position	25.00"	25.00"	25.00"
Tine Spacing	9.50"	10.00"	8.50"
Weight (lbs)	1095#	1150#	1220#
Cylinder Specifications			
Bore	2.50"	2.50"	2.50"
Stroke	9.00"	9.00"	9.00"
Rod Diameter	1.50"	1.50"	1.50"
SPECIFICATIONS AND DESIGN ARE SUBJECT TO CHANGE WITHOUT NOTICE AND WITHOUT LIABILITY THEREFOR.			

**THIS PAGE
IS INTENTIONALLY
BLANK**

PARTS

When servicing your attachment, remember to use only original manufacturer replacement parts. Substitute parts may not meet the standards required for safe, dependable operation.

To facilitate parts ordering when contacting the factory, please have the product control number (PCN) or model and serial number of your product ready to ensure that you receive the correct parts for your specific attachment.

The product control number (PCN), model and serial number for your attachment should be recorded in the space provided on the cover of this manual. This information may be obtained from the serial number identification plate located on your attachment.

NOTE: Most daily and emergency parts orders (in stock) received by 10:30 A.M. (Eastern Standard Time) will be shipped UPS Ground the same day received. UPS Next Day orders must be received by 1 :30 PM (Eastern Standard Time.)

SERVICE DEPARTMENT 1.888.888.1085

WARRANTY

In order to provide you with the most UP-TO-DATE Warranty information, Spartan Equipment Warranty Statement and Warranty Procedures along with Warranty Registration and Claim

Forms have been moved to our website at www.SpartanEquipment.com.