



**SPARTAN
EQUIPMENT®**

OPERATOR'S AND PARTS MANUAL

AUGER DRIVES

X900 High Speed & X1500 High Torque

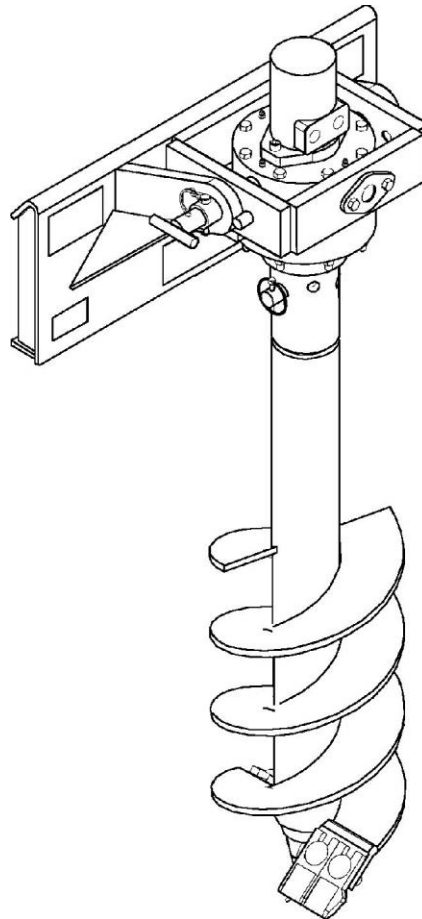

SERIAL NUMBER:

MODEL NUMBER:

Manual Number: OM859

Part Number: 75759

Rev. 1

TABLE OF CONTENTS

AUGER DRIVES

PREFACE	3
SAFETY PRECAUTIONS	
SAFETY STATEMENTS	5
GENERAL SAFETY PRECAUTIONS	5-7
EQUIPMENT SAFETY PRECAUTIONS	8-9
INSTALLATION & OPERATION	
INSTALLING THE DRIVE UNIT	10
INSTALLING AN AUGER	10-11
OPERATION	11-12
STORAGE	13
LIFT POINTS	13
TIE DOWN POINTS	14
TRANSPORTING	14
MAINTENANCE	
SEVICE INTERVALS	15
CHECKING PLANETARY GEAR CASE OIL	15
CHANGING PLANETARY GEAR CASE OIL	15
WEAR PARTS	16
TROUBLESHOOTING	17
LIMITED WARRANTY	19
PARTS	
X900 HIGH SPEED AUGER DRIVE	20-21
X1500 HIGH TORQUE AUGER DRIVE	22-23

**THIS PAGE
IS INTENTIONALLY
BLANK**

PREFACE

GENERAL COMMENTS

Congratulations on the purchase of your new attachment! This product was carefully designed and manufactured to give you many years of dependable service. Only minor maintenance (such as cleaning and lubricating) is required to keep it in top working condition. Be sure to observe all maintenance procedures and safety precautions in this manual and on any safety decals located on the product and on any equipment on which the attachment is mounted.

This manual has been designed to help you do a better, safer job. Read this manual carefully and become familiar with its contents.

WARNING! Never let anyone operate this unit without reading the "Safety Precautions" and "Operating Instructions" sections of this manual.



Always choose hard, level ground to park the vehicle on and set the brake so the unit cannot roll.

Unless noted otherwise, right and left sides are determined from the operator's control position when facing the attachment.

NOTE: The illustrations and data used in this manual were current (according to the information available to us) at the time of printing, however, we reserve the right to redesign and change the attachment as may be necessary without notification.

BEFORE OPERATION

The primary responsibility for safety with this equipment falls to the operator. Make sure the equipment is operated only by trained individuals that have read and understand this manual. If there is any portion of this manual or function you do not understand, contact your local authorized dealer or the manufacturer to obtain further assistance. Keep this manual available for reference. Provide the manual to any new owners and/or operators.

SAFETY ALERT SYMBOL



This is the "Safety Alert Symbol" used by this industry. This symbol is used to warn of possible injury. Be sure to read all warnings carefully. They are included for your safety and for the safety of others working with you.

SERVICE

Use only manufacturer replacement parts. Substitute parts may not meet the required standards.

Record the model and serial number of your unit on the cover of this manual. The parts department needs this information to insure that you receive the correct parts.

SOUND AND VIBRATION

Sound pressure levels and vibration data for this attachment are influenced by many different parameters: some items are listed below (not inclusive):

- prime mover type, age, condition, with or without cab enclosure and configuration
- operator training, behavior, stress level
- job site organization, working material condition, environment

Based on the uncertainty of the prime mover, operator, and job site, it is not possible to get precise machine and operator sound pressure levels or vibration levels for this attachment.

**THIS PAGE
IS INTENTIONALLY
BLANK**

SAFETY STATEMENTS



THIS SYMBOL BY ITSELF OR WITH A WARNING WORD THROUGHOUT THIS MANUAL IS USED TO CALL YOUR ATTENTION TO INSTRUCTIONS INVOLVING YOUR PERSONAL SAFETY OR THE SAFETY OF OTHERS. FAILURE TO FOLLOW THESE INSTRUCTIONS CAN RESULT IN INJURY OR DEATH.



DANGER THIS SIGNAL WORD INDICATES A HAZARDOUS SITUATION WHICH, IF NOT AVOIDED, WILL RESULT IN DEATH OR SERIOUS INJURY.



WARNING THIS SIGNAL WORD INDICATES A HAZARDOUS SITUATION WHICH, IF NOT AVOIDED, COULD RESULT IN DEATH OR SERIOUS INJURY.



CAUTION THIS SIGNAL WORD INDICATES A HAZARDOUS SITUATION WHICH, IF NOT AVOIDED, COULD RESULT IN MINOR OR MODERATE INJURY.

NOTICE

NOTICE IS USED TO ADDRESS PRACTICES NOT RELATED TO PHYSICAL INJURY.

GENERAL SAFETY PRECAUTIONS

WARNING!



READ MANUAL PRIOR TO INSTALLATION

Improper installation, operation, or maintenance of this equipment could result in serious injury or death. Operators and maintenance personnel should read this manual, as well as all manuals related to this equipment and the prime mover thoroughly before beginning installation, operation, or maintenance. **FOLLOW ALL SAFETY INSTRUCTIONS IN THIS MANUAL AND THE PRIME MOVER'S MANUAL(S).**



READ AND UNDERSTAND ALL SAFETY STATEMENTS

Read all safety decals and safety statements in all manuals prior to operating or working on this equipment. Know and obey all OSHA regulations, local laws, and other professional guidelines for your operation. Know and follow good work practices when assembling, maintaining, repairing, mounting, removing, or operating this equipment.



KNOW YOUR EQUIPMENT

Know your equipment's capabilities, dimensions, and operations before operating. Visually inspect your equipment before you start, and never operate equipment that is not in proper working order with all safety devices intact. Check all hardware to ensure it is tight. Make certain that all locking pins, latches, and connection devices are properly installed and secured. Remove and replace any damaged, fatigued, or excessively worn parts. Make certain all safety decals are in place and are legible. Keep decals clean, and replace them if they become worn or hard to read.

GENERAL SAFETY PRECAUTIONS

WARNING!



PROTECT AGAINST FLYING DEBRIS

Always wear proper safety glasses, goggles, or a face shield when driving pins in or out, or when any operation causes dust, flying debris, or any other hazardous material.

WARNING!



LOWER OR SUPPORT RAISED EQUIPMENT

Do not work under raised booms without supporting them. Do not use support material made of concrete blocks, logs, buckets, barrels, or any other material that could suddenly collapse or shift positions. Make sure support material is solid, not decayed, warped, twisted, or tapered. Lower booms to ground level or on blocks. Lower booms and attachments to the ground before leaving the cab or operator's station.

WARNING!



USE CARE WITH HYDRAULIC FLUID PRESSURE

Hydraulic fluid under pressure can penetrate the skin and cause serious injury or death. Hydraulic leaks under pressure may not be visible. Before connecting or disconnecting hydraulic hoses, read your prime mover's operator's manual for detailed instructions on connecting and disconnecting hydraulic hoses or fittings.

- Keep unprotected body parts, such as face, eyes, and arms as far away as possible from a suspected leak. Flesh injected with hydraulic fluid may develop gangrene or other permanent disabilities.
- If injured by injected fluid, see a doctor at once. If your doctor is not familiar with this type of injury, ask him or her to research it immediately to determine proper treatment.
- Wear safety glasses, protective clothing, and use a piece of cardboard or wood when searching for hydraulic leaks. **DO NOT USE YOUR HANDS! SEE ILLUSTRATION.**

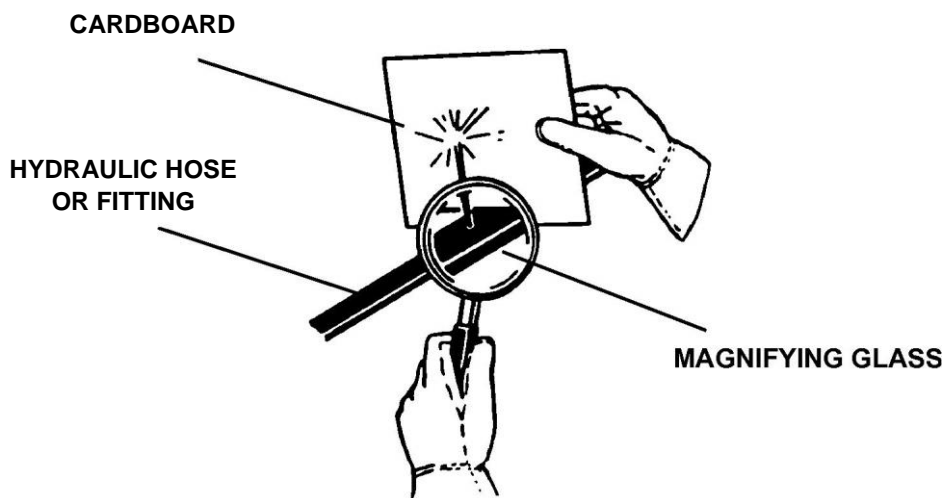

GENERAL SAFETY PRECAUTIONS

WARNING!



DO NOT MODIFY MACHINE OR ATTACHMENTS

Modifications may weaken the integrity of the attachment and may impair the function, safety, life, and performance of the attachment. When making repairs, use only the manufacturer's genuine parts, following authorized instructions. Other parts may be substandard in fit and quality. Never modify any ROPS (Roll Over Protection Structure) or FOPS (Falling Object Protective Structure) equipment or device. Any modifications must be authorized in writing by the manufacturer.

WARNING!



SAFELY MAINTAIN AND REPAIR EQUIPMENT

- Do not wear loose clothing or any accessories that can catch in moving parts. If you have long hair, cover or secure it so that it does not become entangled in the equipment.
- Work on a level surface in a well-lit area.
- Use properly grounded electrical outlets and tools.
- Use the correct tools for the job at hand. Make sure they are in good condition for the task required.
- Wear the protective equipment specified by the tool manufacturer.

SAFELY OPERATE EQUIPMENT



Do not operate equipment until you are completely trained by a qualified operator in how to use the controls, know its capabilities, dimensions, and all safety requirements. See your machine's manual for these instructions.

- Keep all step plates, grab bars, pedals, and controls free of dirt, grease, debris, and oil.
- Never allow anyone to be around the equipment when it is operating.
- Do not allow riders on the attachment or the prime mover.
- Do not operate the equipment from anywhere other than the correct operator's position.
- Never leave equipment unattended with the engine running, or with this attachment in a raised position.
- Do not alter or remove any safety feature from the prime mover or this attachment.
- Know your work site safety rules as well as traffic rules and flow. When in doubt on any safety issue, contact your supervisor or safety coordinator for an explanation.

WARNING!



CALIFORNIA PROPOSITION 65 WARNING

This product may contain a chemical known to the state of California to cause cancer, or birth defects or other reproductive harm. www.P65Warnings.ca.gov

EQUIPMENT SAFETY PRECAUTIONS



KNOW WHERE UTILITIES ARE

Observe overhead electrical and other utility lines. Be sure equipment will clear them. When digging, call your local utilities for location of buried utility lines, gas, water, and sewer, as well as any other hazard you may encounter.

WARNING!



EXPOSURE TO RESPIRABLE CRYSTALLINE SILICA DUST ALONG WITH OTHER HAZARDOUS DUSTS MAY CAUSE SERIOUS OR FATAL RESPIRATORY DISEASE.

It is recommended to use dust suppression, dust collection and if necessary personal protective equipment during the operation of any attachment that may cause high levels of dust.

WARNING!



REMOVE PAINT BEFORE WELDING OR HEATING

Hazardous fumes/dust can be generated when paint is heated by welding, soldering or using a torch. Do all work outside or in a well ventilated area and dispose of paint and solvent properly. Remove paint before welding or heating.

When sanding or grinding paint, avoid breathing the dust. Wear an approved respirator. If you use solvent or paint stripper, remove stripper with soap and water before welding. Remove solvent or paint stripper containers and other flammable material from area. Allow fumes to disperse at least 15 minutes before welding or heating.

WARNING!



END OF LIFE DISPOSAL

At the completion of the useful life of the unit, drain all fluids and dismantle by separating the different materials (rubber, steel, plastic, etc.). Follow all federal, state and local regulations for recycling and disposal of the fluid and components.

OPERATING THE AUGER



- All bystanders should be kept a minimum of 10 feet (3 meters) away from the working area of the earth auger.

Operate only from the operator's station.

Avoid steep hillside operation which could cause the prime mover to overturn. Consult your prime mover operator's and safety manuals for maximum incline allowable. Reduce speed when driving over rough terrain, on a slope, or turning, to avoid overturning the vehicle.

An operator must not use drugs or alcohol, which can change his or her alertness or coordination. An operator taking prescription or over-the-counter drugs should seek medical advice on whether or not he or she can safely operate equipment.

Before exiting the prime mover, lower the attachment to the ground, apply the parking brakes, turn off the prime mover's engine, and remove the key.

- Flow and pressure gauges, fittings, and hoses must have a continuous operating pressure rating of at least 25 higher than highest pressures of the system.

EQUIPMENT SAFETY PRECAUTIONS



TRANSPORTING THE AUGER

Travel only with the earth auger in a safe transport position to prevent uncontrolled movement. Drive slowly over rough ground and on slopes.

Tether the earth auger with a chain, if necessary, to prevent uncontrolled swinging of the auger when moving from hole to hole.

Do not drive close to ditches, excavations, etc., cave in could result.

Do not smoke when refueling the prime mover. Allow room in the fuel tank for expansion.

Wipe up any spilled fuel. Secure cap tightly when done.

Remove the earth auger from the prime mover before transporting to and from the job site.



MAINTAINING THE AUGER

Before performing maintenance, lower the attachment to the ground, apply the parking brakes, turn off the engine, and remove the key.

Never adjust a relief valve for pressure higher than recommended by the prime mover manufacturer.

Never perform any work on an attachment unless you are authorized and qualified to do so. Always read the operator service manual's before any repair is made. After completing maintenance or repair, check for correct functioning of the attachment. If not functioning properly, always tag "DO NOT OPERATE" until all problems are corrected.

Worn, damaged, or illegible safety decals must be replaced. New safety decals can be ordered from Spartan Equipment® free of charge.

Never make hydraulic repairs while the system is under pressure. Serious personal injury or death could occur.

INSTALLATION & OPERATION

3.

INSTALLING THE DRIVE UNIT

2. READ AND UNDERSTAND ALL SAFETY INFORMATION BEFORE ATTEMPTING INSTALLATION.

NOTE: Always use the mini loader to lift and move the drive unit. To move an auger without the drive unit, sling a strap over each end of the auger and hoist it to the desired location.

2. Remove bucket or other attachment from mini loader quick attach mechanism.
2. Attach the mounting bracket with the drive assembly to the mini loader's quick attach mechanism, as per the manufacturer's recommendations. *Refer to your mini loader's Operator's Manual for more information on installing and removing attachments.*

INSTALLING AN AUGER

1. Lower the loader arms and rotate frame until the drive unit is on the ground and the output shaft is facing away from the loader. See Figure #1
1. Align the locking holes on the mounting frame ears with the locking holes on the dual pivot gimbal. Remove .50" x 2.00" capscrews #1092 and hex nuts #1228 from their storage location and install through the locking holes on both sides of the mounting frame. This will lock the drive unit in position for installing the extension/auger. (NOTE: Locking the drive unit allows for easy alignment of the output shaft to the extension/auger, whether it is located on the ground on a trailer.) See Figure #1
3. Slowly drive up to the extension/auger, aligning the extension/auger over the output shaft, secure with pin #22262 and klik pin #21169. See Figure #1

FIGURE #1

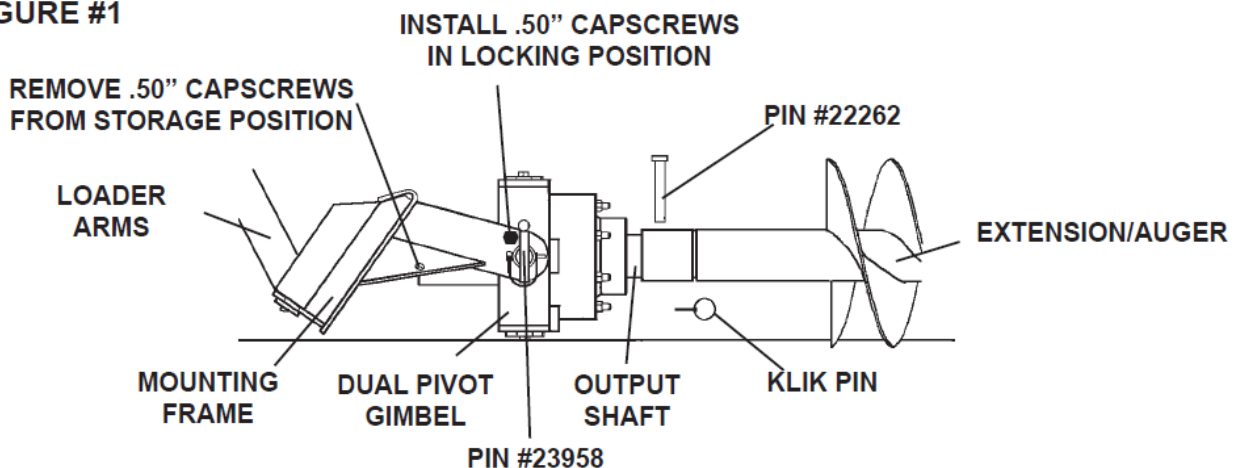

NOTE: When pin #23958 is installed in the locked position, it will lock out the left to right pivoting function. With the pin in the unlocked position, the auger is free to pivot in both directions.

M-834 5-4-05

INSTALLATION & OPERATION

WARNING! KEEP HANDS AND FINGERS AWAY FROM THE MOUNTING ARMS ON THE MOUNTING BRACKET. The auger drive unit swings freely in the mounting arms whenever it is not locked in position. Hands or fingers could get pinched, severely injured or amputated if caught between the mounting arms and the swinging drive head.



4. After the auger is securely attached to the drive unit, and still supported by either the trailer or the ground, remove the .50" capscrews #1092 and hex nuts #1228 from the locking position and install in the storage position. Start the engine and raise the auger free of the ground.

CAUTION! Do not operate the extension/auger in the locked position. Machine damage can occur.

5. When the auger is vertical, tilt the attachment plate back, until the drive head contacts the attachment plate. This will stabilize the auger and keep it from swinging freely. See Figure #2

FIGURE #2

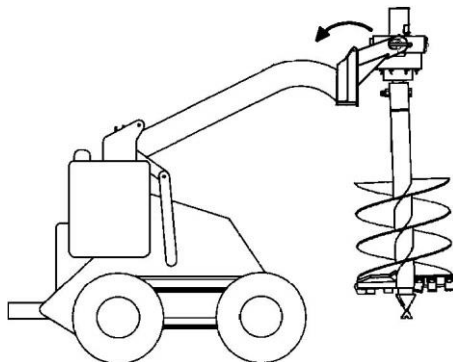

RAISE THE AUGER AND TILT BACK TO STABILIZE THE AUGER AND KEEP IT FROM SWINGING

OPERATION

DANGER! There may be buried power, gas, and/or utility lines in the work area that may cause electrocution or an explosion. Have the work area marked for buried lines and do not dig in the marked areas. If a utility line has been damaged, contact the affected utility at once.



IMPORTANT: Only use the auger if the point and teeth are intact and in good condition. Before digging, ensure that the ground is free of debris.

1. Lower the auger to the ground at the site of the proposed hole.
2. Increase the engine rpm and engage the auxiliary hydraulics.
3. Lower the auger slowly as the soil is loosened.

NOTE: As you dig deeper, move the mini loader backward, forward, right, or left as required to keep the hole vertical.

INSTALLATION & OPERATION

DANGER!



Excessive down force may cause the bit to wobble uncontrollably causing the machine to become unstable and tip over, crushing you or others. **DO NOT** use excessive down pressure on the bit. Allow the bit to pull itself into the soil.

4. When the auger becomes full of soil, disengage the auger drive and lift the auger from the hole. Engage the auger drive to spin off the soil, then resume digging.

NOTE: Switching rapidly from forward to reverse will help to shake off the soil.

STABILITY RATINGS

To determine the degree of slope you can traverse with the auger installed on a mini loader, find the stability rating for the following hill positions in the mini loader operator's manual.

FRONT UPHILL



When positioned with the front of the mini loader uphill, the smaller the auger, the lower the stability rating.

REAR UPHILL



When positioned with the rear of the mini loader uphill, the smaller the auger, the better the stability rating.

SIDE UPHILL



When positioned along the hill, the smaller the auger, the better the stability rating.

It is recommended to use a counterweight when using the auger drive head with an auger larger than 12". Failure to use a counterweight will cause the mini loader to become unstable. Do not use a counterweight when using the auger head without an auger or with an auger smaller than 12". If you use the counterweight, the mini loader will be less stable in the front and side uphill positions.

INSTALLATION & OPERATION

STORAGE

Check that drive unit motor and hoses are full of clean oil and planetary is full.

Coat liberally with grease the output shaft and collar, extension shaft and collar, and all connecting pins to prevent rust and reduce wear.

Clean the unit thoroughly, removing all mud, dirt, and grease.

Inspect for visible signs of wear, breakage, or damage. Order any parts required and make the necessary repairs to avoid delays upon removal from storage.

Tighten loose nuts, capscrews and hydraulic connections.

Seal hydraulic system from contaminants and secure all hydraulic hoses off the ground to help prevent damage.

- Replace decals that are damaged or in unreadable condition.

Store unit in a dry and protected place. Leaving the unit outside will materially shorten its life.

Additional Precautions for Long Term Storage:

Touch up all unpainted surfaces with paint to prevent rust.

REMOVAL FROM STORAGE

Remove cover.

Wash unit and replace any damage and/or missing parts. Check hydraulic hoses for damage and replace as necessary.

LIFT POINTS

Lifting points are identified by lifting decals where required. Lifting at other points is unsafe and can damage attachment. Do not attach lifting accessories around cylinders or in any way that may damage hoses or hydraulic components.

- Attach lifting accessories to unit at recommended lifting points.
- Bring lifting accessories together to a central lifting point.
- Lift gradually, maintaining the equilibrium of the unit.

WARNING!



Use lifting accessories (chains, slings, ropes, shackles and etc.) that are capable of supporting the size and weight of your attachment. Secure all lifting accessories in such a way to prevent unintended disengagement. Failure to do so could result in the attachment falling and causing serious personal injury or death.

INSTALLATION & OPERATION

TIE DOWN POINTS

Tie down points are identified by tie down decals where required. Securing to trailer at other points is unsafe and can damage attachment. Do not attach tie down accessories around cylinders or in any way that may damage hoses or hydraulic components.

- Attach tie down accessories to unit as recommended.
- Check unit stability before transporting.

WARNING!  **Verify that all tie down accessories (chains, slings, ropes, shackles and etc.) are capable of maintaining attachment stability during transporting and are attached in such a way to prevent unintended disengagement or shifting of the unit. Failure to do so could result in serious personal injury or death.**

TRANSPORTING

Follow all local government regulations that may apply along with recommended tie down points and any equipment safety precautions at the front of this handbook when transporting your attachment.

MAINTENANCE

SERVICE INTERVALS

INSPECT AUGER TEETH BEFORE EACH USE
(Replace if damaged.)

CHECK PLANETARY GEAR CASE OIL EVERY 25 HOURS

CHANGE PLANETARY GEAR CASE OILEVERY 1000 HOURS

CHECKING PLANETARY GEAR CASE OIL

Check the oil level in the planetary gear case every 25 hours, and top off the oil if necessary.

1. Place the auger drive head on the ground so that the driveshaft is parallel with the ground.
2. Rotate the drive head so that the oil drain plug is located on top. See Figure #1.
3. Remove the oil drain plug.
4. Rotate the auger drive head so that the drain opening is at the 2 o'clock or 10 o'clock position.
(See Figure #1) Oil should just begin to come out of the opening.
5. If no oil comes out of the opening, add oil (a mild, extreme pressure lubricant API-GL-5, number 80 or 90) until the oil starts to run out when the drain hole is at the 2 o'clock or 10 o'clock position.
6. Replace the drain plug.

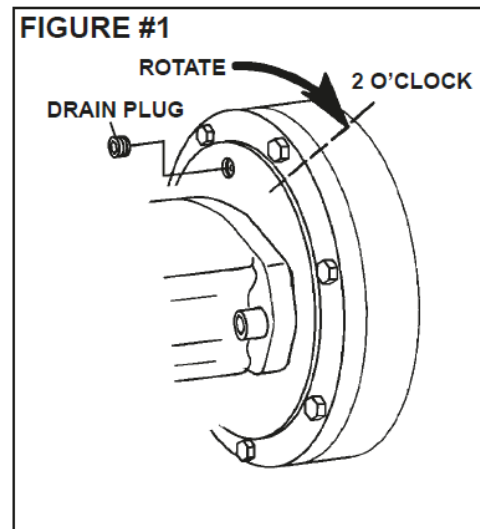

CHANGING PLANETARY GEAR CASE OIL

Change the oil after the first 50 hours of operation and every 1000 hours thereafter. The planetary gear case requires approximately 2 pints of a mild, extreme pressure lubricant, rated APT-GL-5, number 80 or 90.

1. Support the drive head over an oil pan so that the oil drain plug is on the bottom of the drive head, facing the oil pan.
2. Remove the oil drain plug to drain the oil.
3. When the oil is completely drained, turn the drive head so that the oil drain opening is on the top of the drive head, facing up.
4. Add approximately 2 pints of a mild, extreme pressure lubricant, rated APT-GL-5, number 80 or 90.
5. Replace the drain plug.

M-837 5-4-04

HDC STYLE AUGER WEAR PARTS LIST

AUGER DIA.	6"	8"	9"	10"	12"	15"	16"	18"	20"	24"	30"	36"	42"	48"
Part #	152 mm	203 mm	229 mm	254 mm	305 mm	381 mm	406 mm	457 mm	508 mm	610 mm	762 mm	914 mm	1067 mm	1219 mm
Qty	2	2	2	2	2	2	2	2	2	2	2	2	2	2
Description/Standard Components	Hardened Drive-In Gage Tooth	Hardened Drive-In Gage Tooth	Hardened Drive-In Gage Tooth	Hardened Drive-In Gage Tooth	Hardened Drive-In Gage Tooth	Hardened Drive-In Gage Tooth	Hardened Drive-In Gage Tooth	Hardened Drive-In Gage Tooth	Hardened Drive-In Gage Tooth	Hardened Drive-In Gage Tooth	Hardened Drive-In Gage Tooth	Hardened Drive-In Gage Tooth	Hardened Drive-In Gage Tooth	Hardened Drive-In Gage Tooth
Part #	22189	22189	22189	22189	22189	22189	22189	22189	22189	22189	22189	22189	22189	22189
Qty	1	1	1	1	1	1	1	1	1	1	1	1	1	1
Description/Standard Components	3.50" Hardened Fishtail Point (male shaft)	3.50" Hardened Fishtail Point (male shaft)	3.50" Hardened Fishtail Point (male shaft)	3.50" Hardened Fishtail Point (male shaft)	3.50" Hardened Fishtail Point (male shaft)	3.50" Hardened Fishtail Point (male shaft)	3.50" Hardened Fishtail Point (male shaft)	3.50" Hardened Fishtail Point (male shaft)	3.50" Hardened Fishtail Point (male shaft)	3.50" Hardened Fishtail Point (male shaft)	3.50" Hardened Fishtail Point (male shaft)	3.50" Hardened Fishtail Point (male shaft)	3.50" Hardened Fishtail Point (male shaft)	3.50" Hardened Fishtail Point (male shaft)
Part #	22154													
Qty	2	4	4	4	4	6	6	6	6	8	10	12	16	20
Description/Standard Components	Rubber Lock													

HDF STYLE AUGER WEAR PARTS LIST

AUGER DIA.	4"	6"	8"	9"	10"	12"	15"	16"	18"	20"	24"	30"	36"	48"
Part #	102 mm	152 mm	203 mm	229 mm	254 mm	305 mm	381 mm	406 mm	457 mm	508 mm	610 mm	762 mm	914 mm	1219 mm
Qty	4	2	2	2	2	2	2	2	2	2	2	2	2	4
Description/Standard Components	Hardened Bolt-on Gage Tooth	Hardened Bolt-on Gage Tooth	Hardened Bolt-on Gage Tooth	Hardened Bolt-on Gage Tooth	Hardened Bolt-on Gage Tooth	Hardened Bolt-on Gage Tooth	Hardened Bolt-on Gage Tooth	Hardened Bolt-on Gage Tooth	Hardened Bolt-on Gage Tooth	Hardened Bolt-on Gage Tooth	Hardened Bolt-on Gage Tooth	Hardened Bolt-on Gage Tooth	Hardened Bolt-on Gage Tooth	Hardened Bolt-on Gage Tooth
Part #	22169	22169	22169	22169	22169	22169	22169	22169	22169	22169	22169	22169	22169	22169
Qty	3	1	1	1	1	1	1	1	1	1	1	1	1	13
Description/Standard Components	3.50" Hardened Fishtail Point (male shaft)	3.50" Hardened Fishtail Point (male shaft)	3.50" Hardened Fishtail Point (male shaft)	3.50" Hardened Fishtail Point (male shaft)	3.50" Hardened Fishtail Point (male shaft)	3.50" Hardened Fishtail Point (male shaft)	3.50" Hardened Fishtail Point (male shaft)	3.50" Hardened Fishtail Point (male shaft)	3.50" Hardened Fishtail Point (male shaft)	3.50" Hardened Fishtail Point (male shaft)	3.50" Hardened Fishtail Point (male shaft)	3.50" Hardened Fishtail Point (male shaft)	3.50" Hardened Fishtail Point (male shaft)	3.50" Hardened Fishtail Point (male shaft)
Part #	22306	22306	22306	22306	22306	22306	22306	22306	22306	22306	22306	22306	22306	22306
Qty	7	2	2	2	2	2	2	2	2	2	2	2	2	17
Description/Standard Components	Carriage Bolt	Carriage Bolt	Carriage Bolt	Carriage Bolt	Carriage Bolt	Carriage Bolt	Carriage Bolt	Carriage Bolt	Carriage Bolt	Carriage Bolt	Carriage Bolt	Carriage Bolt	Carriage Bolt	Carriage Bolt
Part #	1839													
Qty	7	2	2	2	2	2	2	2	2	2	2	2	2	17
Description/Standard Components	Nut	Nut	Nut	Nut	Nut	Nut	Nut	Nut	Nut	Nut	Nut	Nut	Nut	Nut

HTF STYLE AUGER WEAR PARTS LIST

AUGER DIA.	18"	24"	30"	36"	42"	48"
Part #	457 mm	610 mm	762 mm	914 mm	1067 mm	1219 mm
Qty	4	4	4	4	4	4
Description/Standard Components	Hardened Bolt-on Gage Tooth	Hardened Bolt-on Gage Tooth	Hardened Bolt-on Gage Tooth	Hardened Bolt-on Gage Tooth	Hardened Bolt-on Gage Tooth	Hardened Bolt-on Gage Tooth
Part #	22169	22169	22169	22169	22169	22169
Qty	3	6	7	9	11	13
Description/Standard Components	3.50" Hardened Fishtail Point (male shaft)	3.50" Hardened Fishtail Point (male shaft)	3.50" Hardened Fishtail Point (male shaft)	3.50" Hardened Fishtail Point (male shaft)	3.50" Hardened Fishtail Point (male shaft)	3.50" Hardened Fishtail Point (male shaft)
Part #	22306	22306	22306	22306	22306	22306
Qty	7	10	11	13	15	17
Description/Standard Components	Carriage Bolt	Carriage Bolt	Carriage Bolt	Carriage Bolt	Carriage Bolt	Carriage Bolt
Part #	1839					
Qty	7	10	11	13	15	17
Description/Standard Components	Nut	Nut	Nut	Nut	Nut	Nut

OPTIONAL HARDFACED & CARBIDE WEAR COMPONENTS

Part #	Description
22170	Hardfaced Wisdom Tooth
22186	Carbide Wisdom Tooth
22181	Hardfaced Chisel Tooth
22183	Hardfaced Chisel Tooth
22182	Carbide Chisel Tooth
22190	3.50" Hardfaced Fishtail Point (Male Hub)
22192	3.50" Hardfaced Fishtail Point (Male Hub)
22191	3.50" Carbide Fishtail Point (Male Hub)
22193	3.50" Hardfaced / Carbide Fishtail Point (Male Hub)
22003	4.50" Hardfaced Fishtail Point (Female)
22004	4.50" Hardfaced Fishtail Point (Female)
22005	4.50" Hardfaced / Carbide Fishtail Point (Female)
22171	3.50" Hardfaced Fishtail Point (Female)
22172	3.50" Carbide Fishtail Point (Female)
22173	3.50" Hardfaced Fishtail Point (Female)
22174	3.50" Hardfaced / Carbide Fishtail Point (Female)

IMPORTANT: McMillen does not recommend augers exceeding 36" diameter for C-Series Drive Units.

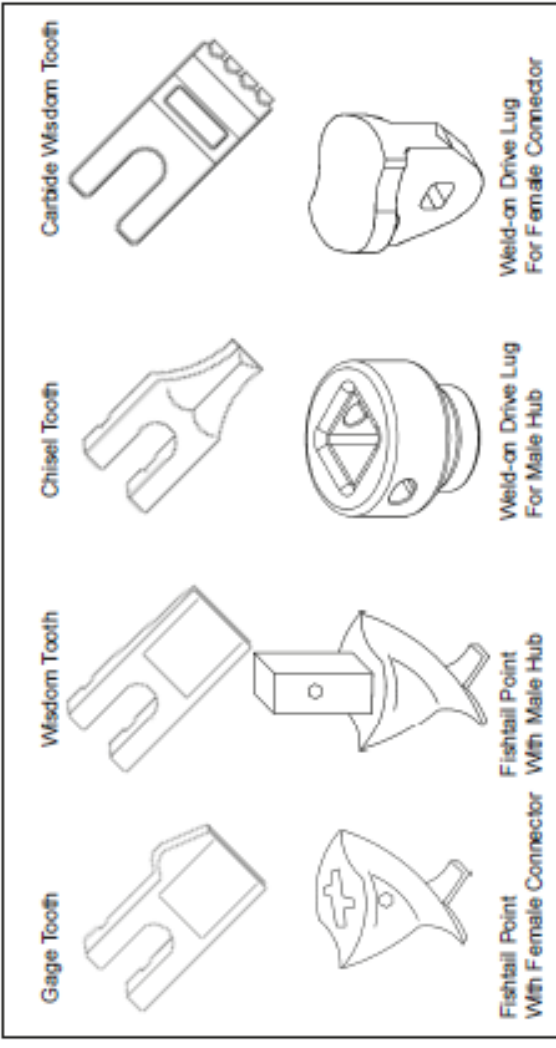

NOTE: Contact your equipment dealer for wear components not listed above. If you have any special auger needs or applications, feel free to contact McMillen.

TROUBLESHOOTING

PROBLEM	POSSIBLE CAUSE	POSSIBLE SOLUTION
Drive head does not operate.	Hydraulic coupler not completely connected.	Check and tighten all couplers.
	Defective hydraulic coupler.	Check couplers and replace if defective.
	Obstruction in hydraulic hose.	Find and remove obstruction.
	Kinked hydraulic hose.	Replace the kinked hose.
	Contamination in the gearbox.	Call Authorized Service Dealer.
Slow Speed	Low Flow	Check with flow meter. If low investigate cause.
	Line restrictions	Clear lines
	Fittings or connections too small	Replace with proper sizes.
	Oil filter dirty	Replace
	Hydraulic pump worn or damaged	See Dealer for repair
Insufficient Digging Power	Worn teeth or point	Replace
	Low system Pressure (PSI)	Check with pressure gauge. If low, investigate cause.
	Relief Valve damaged or setting wrong	Adjust or replace as required.
	Excessive load	Reduce load to within machine
Reverse Direction	Hoses reversed	Re-install hoses correctly.
Excessive Oil Heating	Line restrictions	Clear lines
	Fluid dirty	Replace hydraulic fluid and filter.
	Insufficient quantity of hydraulic fluid	Fill reservoir to proper level. Increase reservoir storage capacity.
Oil Leaks	Hoses loose or damaged	Tighten or replace
	Fittings loose or damaged	Tighten or replace
	Hydraulic motor seals worn or damaged	See Dealer for repair.

M-838 5-4-05

**THIS PAGE
IS INTENTIONALLY
BLANK**

LIMITED WARRANTY

In order to provide you with the most UP-TO-DATE Warranty information please visit our website www.spartanequipment.com.

MODELX900 HIGH SPEED AUGER DRIVE

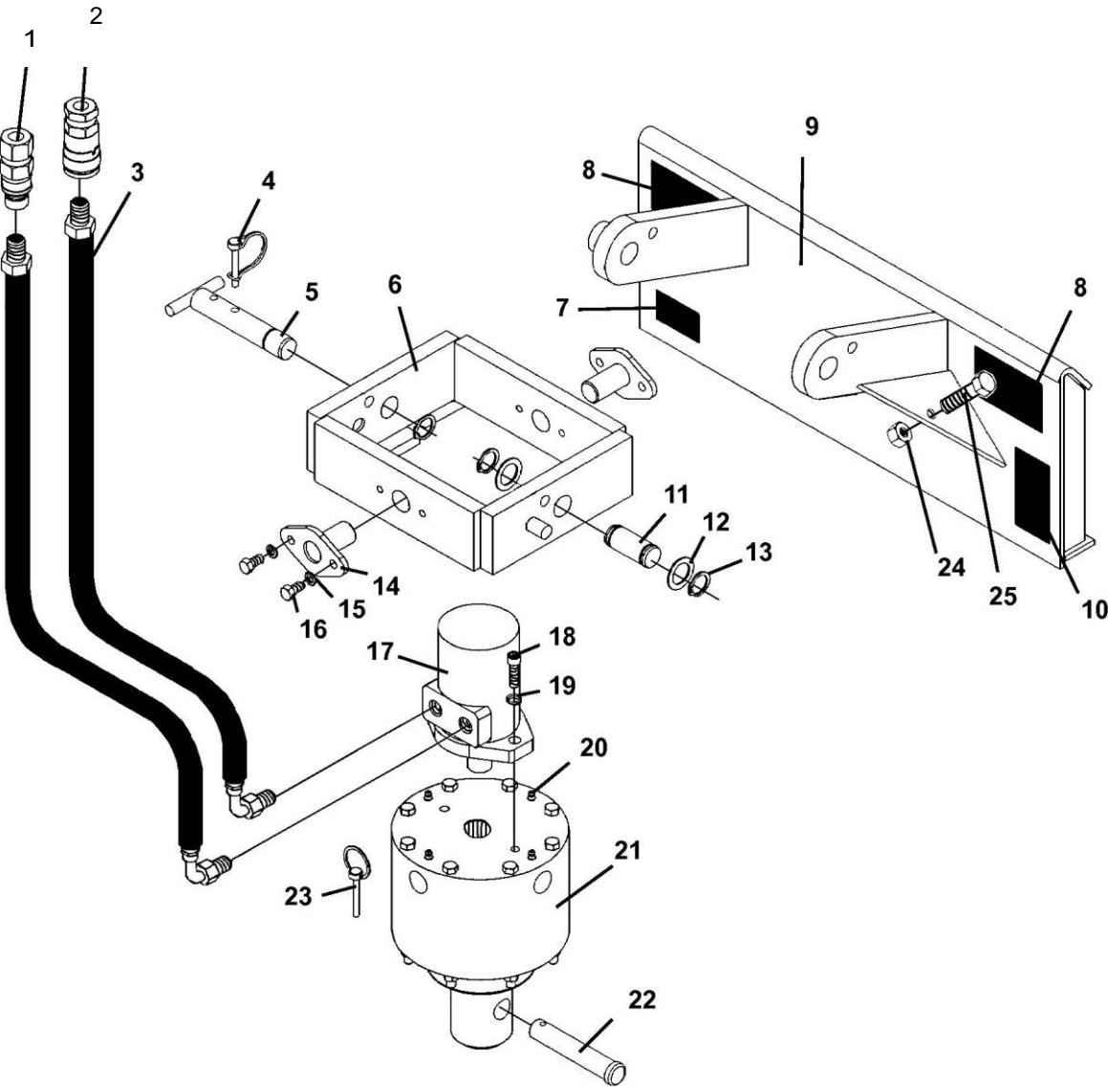

M-799 6-10-14-3

MODEL X900 HIGH SPEED AUGER DRIVE

<u>NO</u>	<u>REQ'D</u>	<u>PART NO.</u>	<u>DESCRIPTION</u>
1	1	24001	Male Coupler - Flat Face Style - 10FBo
	1	15512	Male Coupler - Poppet Style - 10FBo
2	1	24002	Female Coupler - Flat Face Style - 10FBo
	1	31886	Female Coupler - Poppet Style - 10FBo
3	2	38012	Hose .50" X 66" 10MBo - 10MBo 90°
4	1	22269	Lynch Pin
5	1	23958	Pin
6	1	23959	Dual Pivot Gimbel
7	1	--	Serial Number Tag Location
8	2	40582	Danger Decal
9	1	23960*	Universal Mounting Frame
10	1	40440	Call Before You Dig Decal
11	1	54030	Pin
12	2	57462	Thrust Washer
13	3	6612	Snap Ring
14	2	23961	Pin
15	4	1503	.38" Lock Washer
16	4	1043	.38" UNC X 1.00" Hex Capscrew
17	1	16695	Hydraulic Motor - 4.0 Cu. In.
	1	45412	O-Ring
18	2	1907	.50" UNC X 1.25" SocketHead Capscrew
19	2	1505	.50" Lock Washer
20	4	6616	Replacement Grease Fitting
21	1	23957	Planetary - Digga
22	1	22262	Pin
23	1	21169	Klik Pin
24	2	1228	.50" UNC Hex Nut
25	2	1092	.50" UNC X 2.00" Hex Capscrew

* Mounting frames and couplers are specific to your loader application. Contact Spartan Equipment for these items that are not listed above.

M-800 6-1 0-14-3

MODELX1500 HIGH TORQUE AUGER DRIVE

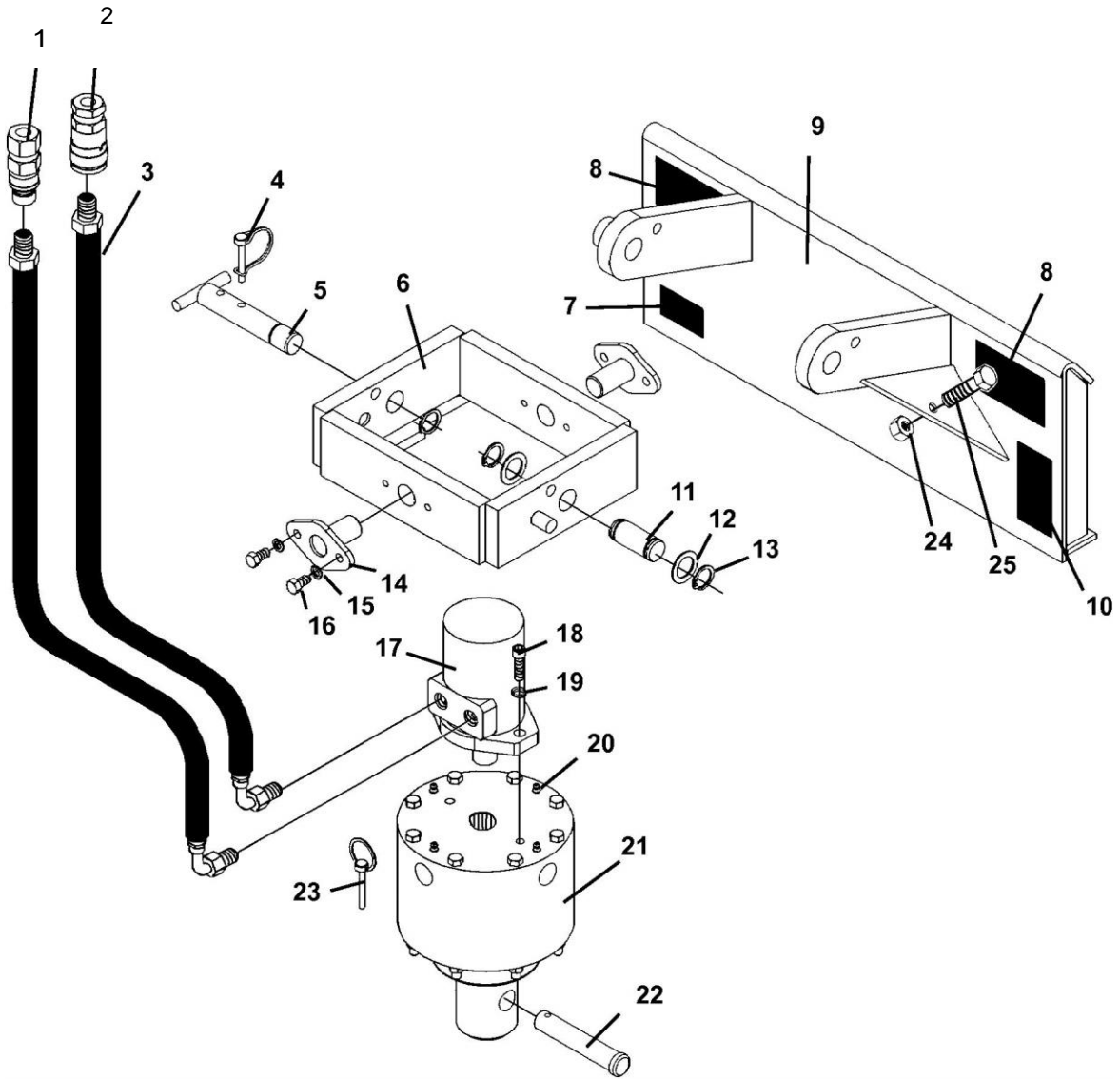

M-801 6-10-14-3

MODELX1500 HIGH TORQUE AUGER DRIVE

<u>NO</u>	<u>REQ'D</u>	<u>PART NO.</u>	<u>DESCRIPTION</u>
1	1	24001	Male Coupler - Flat Face Style - 10FBo
	1	15512	Male Coupler - Poppet Style - 10FBo
2	1	24002	Female Coupler - Flat Face Style - 10FBo
	1	31886	Female Coupler - Poppet Style - 10FBo
3	2	38012	Hose .50" X 66" 10MBo - 10MBo 90°
4	1	22269	Lynch Pin
5	1	23958	Pin
6	1	23959	Dual Pivot Gimbel
7	1	--	Serial Number Tag Location
8	2	40582	Danger Decal
9	1	23960*	Universal Mounting Frame
10	1	40440	Call Before You Dig Decal
11	1	54030	Pin
12	2	57462	Thrust Washer
13	3	6612	Snap Ring
14	2	23961	Pin
15	4	1503	.38" Lock Washer
16	4	1043	.38" UNC X 1.00" Hex Capscrew
17	1	33211	Hydraulic Motor - 8.0 Cu. In.
	1	45412	O-Ring
18	2	1907	.50" UNC X 1.25" SocketHead Capscrew
19	2	1505	.50" Lock Washer
20	4	6616	Replacement Grease Fitting
21	1	23957	Planetary
22	1	22262	Pin
23	1	21169	Klik Pin
24	2	1228	.50" UNC Hex Nut
25	2	1092	.50" UNC X 2.00" Hex Capscrew

* Mounting frames and couplers are specific to your loader application. Contact Spartan Equipment for these items that are not listed above.