



**SPARTAN
EQUIPMENT®**

Mini Trencher

For

Mini Skid Steer Loaders

And

Mini Track Loaders

**Operator's Manual
Maintenance
Parts Information**



Read this Manual Before Use

TABLE OF CONTENTS

SAFETY	3-4
SERIAL NUMBER/DECAL LOCATION	5-6
MOUNTING INSTRUCTIONS	7-8
OPERATING INSTRUCTIONS	9
ROUTINE MAINTENANCE	10
PARTS INFORMATION	11-13
GENERAL SPECIFICATIONS	14
WARRANTY	15

REFERENCE INFORMATION

Write the serial number for your attachment in the spaces below. Always refer to this serial number when calling for service or parts.

Serial Number....._____

YOUR ATTACHMENTS DEALER

ADDRESS:

PHONE:

CONTACT:

NOTE: *Spartan Equipment reserves the right to make improvements in design or changes in specifications at any time without notice and without incurring any obligations to install them on units previously sold.*

SAFETY

DO NOT use or perform maintenance on this machine until this manual has been read and understood. In addition, read the Operation and Maintenance Manual(s) pertaining to the attachment and the attachment carrier (“Loader”).

The user is responsible for inspecting the machine daily, and for having parts repaired or replaced when continued use of the machine would cause damage, excessive wear to other parts or make the machine unsafe for continued operation.

If an operating procedure, tool device, maintenance or work method not specifically recommended is used, you must satisfy yourself that it is safe for you and others. You must also ensure that the attachment will not be damaged or made unsafe by the procedures you choose.

Spartan Equipment cannot anticipate every possible circumstance that might involve potential hazard. The safety messages found in this manual and on the machine are therefore not all inclusive.

The signal words **CAUTION**, **WARNING**, or **DANGER** are used to indicate hazards.

⚠ CAUTION Indicates a potentially hazardous situation which, if not avoided, may result in minor or moderate injury.

⚠ WARNING Indicates a potentially hazardous situation which, if not avoided, could result in death or serious injury.

⚠ DANGER Indicates a potentially hazardous situation which, if not avoided, will result in death or serious injury.

The word **IMPORTANT**, is used in the text when immediate damage will occur due to improper technique or operation.

The word **NOTE** is used to convey information that is out of context with the manual text; special information such as specifications, techniques, reference information, and other information of a supplementary nature.

Call Before You Dig
1-888-258-0808



SAFETY

Improper operation can cause serious injury or death.

Pre-operation

- This attachment is designed to be used for digging utility or drainage trenches on loaders with a Rated Operating Capacity (ROC) of 1000 pounds or less. **NEVER** use this machine for any other purpose.
- Read the operator's manual for the "Skid Steer Loader." **NEVER** allow untrained people to operate.
- Operating instructions must be given to everyone before operating this attachment and at least once a year thereafter in accordance with OSHA regulations.
- **NEVER** exceed the maximum recommended input power or speed specifications for the attachment. Over-powering or over-speeding the attachment may cause personal injury and/or machine damage.
- Keep all shields, guards, and covers in place.
- Do not modify equipment or add attachments that are not approved by Erskine Attachments LLC.
- Use adequate safety warning lights and devices as required by local regulations. Obey all local laws and regulations regarding machine operation on public property. Always call before you dig (1-888-258-0808). When you call, you will be directed to a location in your state/city for information about buried lines (electric, telephone, cable TV, water, sewer, gas, etc.).

Operation

- Always wear eye protection that meets z87.1 or use with a loader enclosure that provides similar protection.
- Hydraulic connections may be hot after use. Use gloves if connecting or disconnecting after use.
- Check and be sure all operating controls are in neutral before starting the engine.

Operation (continued)

- Keep people away from loader and attachment when in use. This attachment has rotating parts.
- **NEVER** operate near embankments or terrain that is so steep that rollover could occur.
- Always stay in the operator position when using the attachment. If you are using a walk-behind loader, stay behind the loader at the controls while operating.
- Before leaving the operators position, disengage hydraulic drive, lower the attachment to rest flat on the ground, stop engine, set park brake, and wait for all motion to stop.
- **NEVER** place hands near attachment or clear debris while the engine is running.

Avoid High Pressure Fluids Hazard



- Escaping fluid under pressure can penetrate the skin causing serious injury.
- Avoid the hazard by relieving the pressure before disconnecting hydraulic lines.
- Use a piece of paper or cardboard, NOT BODY PARTS, to check for suspected leaks. Wear protective gloves and safety glasses or goggles when servicing or performing maintenance on hydraulic systems.
- If an accident occurs, see a doctor immediately. Any fluid injected into the skin must be surgically removed within a few hours or gangrene may result.

Maintenance

- **NEVER** make adjustments, lubricate, clean, or perform any service on the machine while it is in operation.
- Make sure the attachment is serviced on a daily basis. Improper maintenance can cause serious injury or death in addition to damage to the attachment and/or your equipment.

SERIAL NUMBER AND SAFETY DECAL LOCATIONS

Serial Number Location:

It is important to refer to the serial number of your attachment when making repairs or ordering parts. Early or later models (identification made by serial number) may use different parts, or it may be necessary to use different procedures in doing a specific operation.

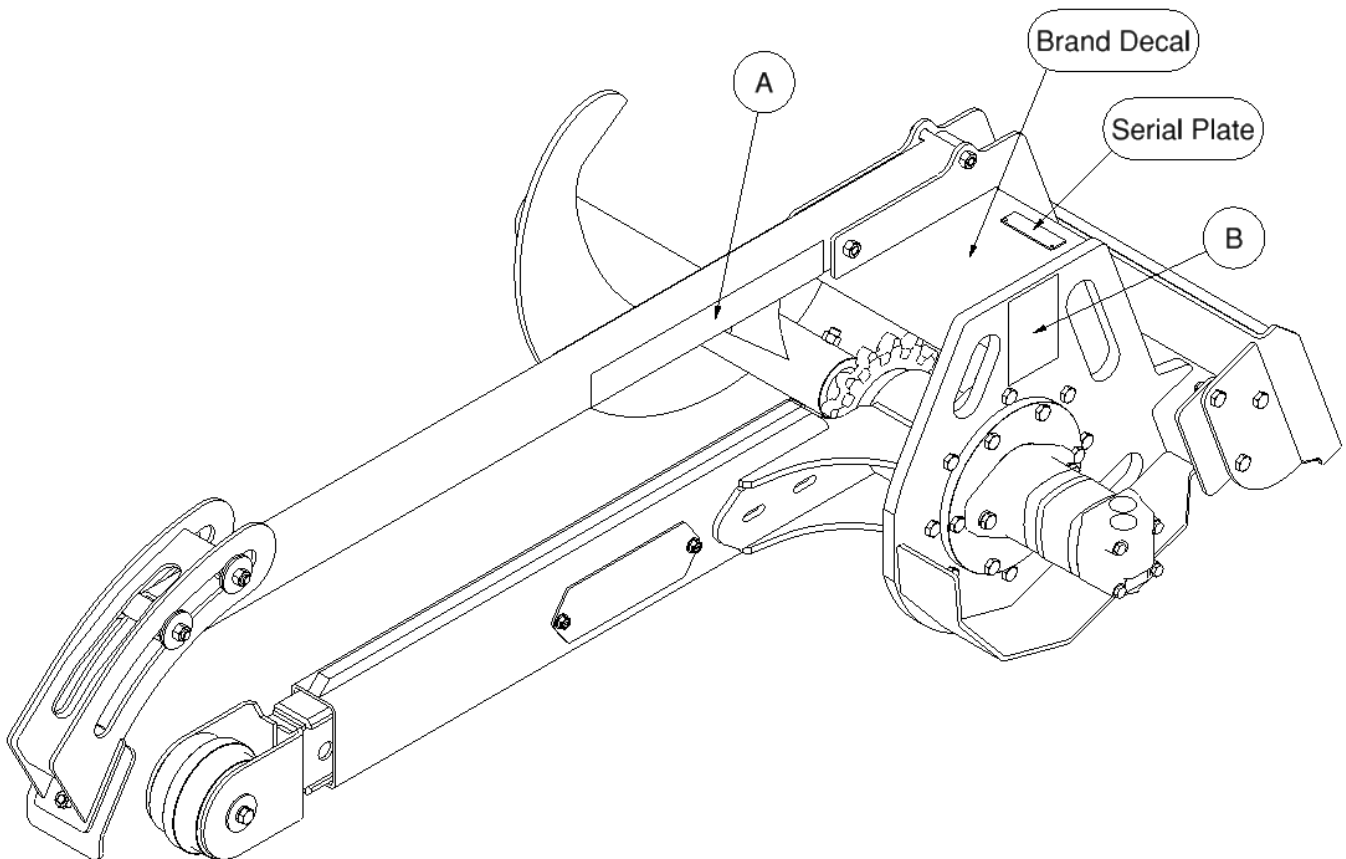

SERIAL NUMBER AND SAFETY DECAL LOCATIONS

(A)



Location: Left and Right side of Crumber Tube Mount
Quantity: 2
Part Number: 317302

(B)



Location: Top of frame assembly near serial plate
Quantity: 1
Small Brand Decal

Location: Left side of Frame Assembly
Quantity: 1
Part Number: 200001

Safety Decals Locations:

The locations of the safety decals are shown. If these decals are missing, damaged, or painted over they must be replaced. Call Spartan Equipment for replacement decals.

MOUNTING INSTRUCTIONS

After uncrating the attachment, use the following procedure to mount the attachment to the loader.

⚠ WARNING Coupler wedges or pins must extend through the holes in the attachment mounting plate. Levers must be fully down and locked. Failure to secure wedges or pins can allow attachment to come off and cause injury or death.

IMPORTANT: The mini trencher is not designed to be used on loaders with a Rated Operating Capacity (ROC) of more than 1000 pounds.

Instructions for mounting to a ride-on mini skid loader:

1. Use the step, safety treads, and grab handles to get on and off the loader.
2. Sitting in the operator's seat, lower seat bar and fasten the seat belt and with the controls in a neutral position, start the engine.
3. Drive the loader to the rear of the attachment. Put the loader quick attach coupler into the attachment mounting bracket.
4. Tilt the loader coupler backward a small amount until it is fully engaged in the attachment mounting bracket.
5. Stop the engine and engage the park brake.
6. Exit the loader and secure the coupler locking mechanism that locks the attachment to the loader.

Instructions for mounting to a walk-behind mini skid loader:

1. Standing at the operator's station with the controls in a neutral position, start the engine.
2. Drive the loader to the rear of the attachment. Put the loader quick attach coupler into the attachment mounting bracket.
3. Tilt the loader coupler backward a small amount until it is fully engaged in the attachment mounting bracket.
4. Stop the engine and engage the park brake.
5. Walk to the front of the loader and secure the coupler locking mechanism that locks the attachment to the loader.

MOUNTING INSTRUCTIONS

Connecting Hydraulics

1. Connect the hydraulic quick couplers from the attachment to the loader.

IMPORTANT: Make sure the quick couplers are fully engaged. If the quick couplers do not fully engage, check to see that the couplers are the same size and brand. Do not force the quick couplers together.

IMPORTANT: Wipe the ends of the hydraulic quick couplers (both lead and loader) with a rag to remove any possible contamination. Contamination can cause hydraulic components to fail and is not covered under warranty.

NOTE: See the loader's operator's manual.

NOTE: Attachment is shipped with 8FJX (3/4" Female JIC Swivel) fittings on the ends of the lead hoses.

2. Connect the wire harness to the loader's wire harness receptacle. (Disregard if a pistol grip controller is supplied with the attachment.)

Make sure the hoses are properly routed to fit your specific loader. If the hoses are not routed correctly, hoses may get pinched or rub on tires. Be sure to check the hose routing through the full range of intended motion of the attachment before operating it.

More than one routing may be acceptable depending on the loader. Pick the routing that best suits your loader.

IMPORTANT: Proper hose routing is the responsibility of the owner and/or operator. Pinched or stretched hoses are not covered under warranty.

Mounting is now complete and you are ready to use the attachment. Use the above instructions in a reverse order to dismount the attachment from the loader.

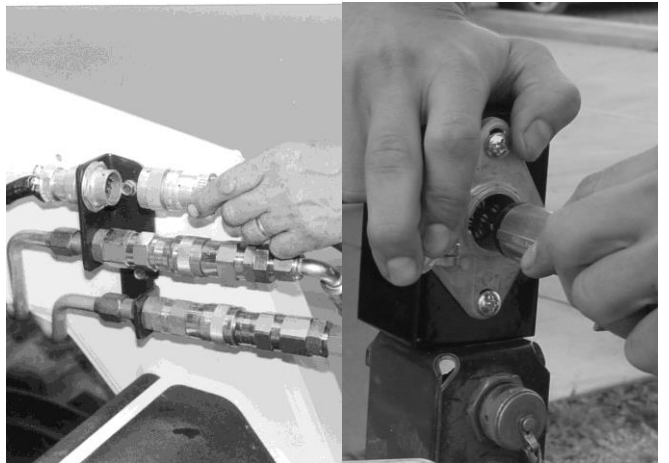
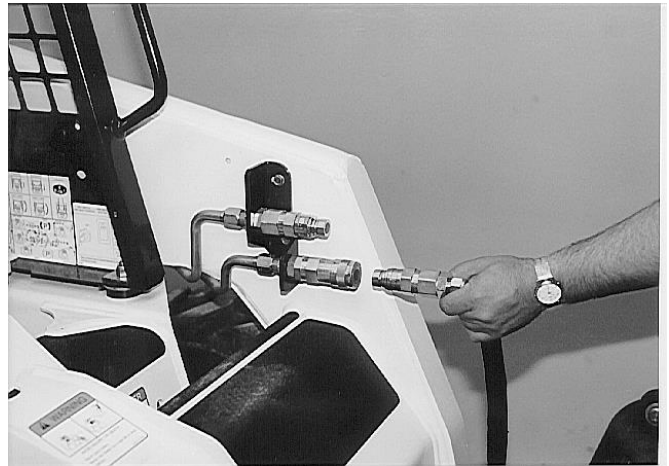

OPERATING INSTRUCTIONS

⚠ WARNING Contact with underground gas or electric utilities can cause serious injury or death.

Call Before You Dig

1-888-258-0808



1. With the operator at the operator's station, the seat belt fastened and the seat bar lowered (if so equipped), start the engine.

⚠ WARNING To avoid injury or death, keep people away from machine when machine is running.

2. Activate the auxiliary hydraulic system to start turning the chain. Make sure the chain is moving in the right direction.

IMPORTANT: Engine must be at idle speed when engaging auxiliary hydraulic system.

3. With the loader boom lowered all the way and the auxiliary hydraulics engaged, slowly rotate the loader mounting coupler forward until the tip of the trencher boom begins to engage the ground.

NOTE: Always operate the trencher with the loader at 100% throttle for maximum power.

4. Raise the loader boom as you continue to rotate the attachment, until you reach the desired depth of cut. Begin backing up slowly as you do this to keep the crumber from digging into the end of the trench.
5. If desired, the loader lift arms can be put in the float position. (See loader's operator's manual.)

NOTE: The trencher is designed to trench at the design depth when the mounting plate is in a nearly horizontal position. This can be used as a visual reference for the operator when trenching.

ROUTINE MAINTENANCE

⚠ WARNING Lower the attachment to rest, shut down the engine, relieve the hydraulic pressure to the attachment, wait for all motion to stop, and set park brake before leaving the operator's seat to perform service of any kind.

It is the operator's responsibility to make daily inspections of the loader and attachment for damage, loose bolts, fluid leaks, or anything else that could cause a potential service or safety problem. Preventive maintenance is the easiest and least expensive type of maintenance.

IMPORTANT: Bolts and set screws can loosen after initial usage. After the first hour of operation check all bolts and set screws.

CHAIN TENSION ADJUSTMENT PROCEDURE (Inspect after first hour of operation)



IMPORTANT: Improper maintenance can cause extensive damage to the attachment and/or your equipment.

IMPORTANT: Chain should be inspected for proper tension after the first hour of operation and after every 4 hours after that. Chain may loosen slightly after initial break-in period.

1. Remove cover bolts to access chain tensioning bolt.
2. Loosen jam nut on tensioning bolt.
3. Loosen or tighten tensioning bolt as needed.

NOTE: Chain should sag about 1-2" when measured from the bottom of the chain guide bar. More sag may be required in sticky soil conditions to prevent the chain from binding due to mud build-up on sprocket and idler. Too much sag may cause the chain to run itself off the idler or sprocket.

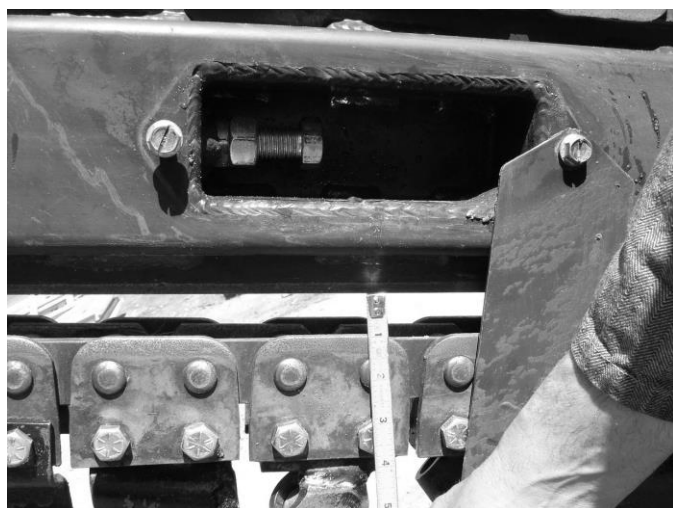

4. Retighten jam nut.
5. Replace bolt-on cover.

MINI HYDRAULIC TRENCHER PARTS INFORMATION

ITEM	QTY	PART NO.	DESCRIPTION	STOCK NUMBER
1	1	319803	BOOM MAIN LF TALL W/A	NEW REPLACED 317202
	1	317202	BOOM MAIN W/A	OBSOLETE
2	1	317488	SHAFT SPRING W/A	
3	1	65127	PIN COTTER 3/16 X 2	
4	1	317486	SPRING COMP 2 OD X 6	
5	1	317485	MOUNT SPRING GUIDE W/A	
6	1	317473	IDLER TRENCHER WIDE LF	NEW STYLE
	1	317224	IDLER TRENCHER LF	OLD STYLE ONLY
7	2	317220	BEARING 1-1/8" SQ BORE	
8	1	317471	SHAFT IDLER WIDE	NEW STYLE
	1	317225	SHAFT IDLER	OLD STYLE ONLY
9	1	317231	COVER PAINTED	
10	1	317234	BOLT HEX TAP 3/4 X 6	
11	1	319806	BOOM END LF 3' WIDE W/A PLASTIC	NEW REPLACED 317475
	1	317475	BOOM END LF 3' WIDE W/A	OBSOLETE
	1	317207	BOOM END LF 3' W/A	OBSOLETE
12	1	317203	AUGER W/A	
13	2	319805	PLASTIC SLIDER CHAMFERED	
14	1	317217	SPROCKET 1.654 X 14 TOOTH	
16	2	32467	BOLT FLG THRD RLNG	3/8 X 3/4 - UNC - GR 5
17	2	317286	RING SNAP INT 3.149 X .109	
18	1	13219	BOLT HEX	1/2 X 4 - UNC - GR 5
19	27	37214	NUT HEX	1/2 - UNC - GR 5 - REV LOCK
20	2	13210	BOLT HEX	1/2 X 1.75 - UNC - GR 5
21	10	317287	WASHER FENDER 1/2" X 2" X 1/8"	
22	4	13205	BOLT HEX	1/2 X 1 - UNC - GR 5
23	6	22876	BOLT 12 PT FLANGE 1/2 X 1-1/2 NC GR9	
24	4	33626	WASHER LOCK	0.5 - GR 5
25	2	317298	SPACER IDLER PAINTED	
26	1	36116	NUT HEX FULL	3/4 NC GR 5
27	2	13221	BOLT HEX	1/2 X 4-1/2 - UNC - GR5
28	1	317310	FRAME DRIVE MINI W/A	
29	6	13207	BOLT HEX	1/2 X 1.25 - UNC - GR 5
30	14	13211	BOLT HEX	1/2 X 2 - UNC - GR 5
34	1	317208	CRUMBER TUBE W/A	
35	4	317272	BUSHING ROLLER	
36	2	317273	BUSHING INNER	
37	1	317209	CRUMBER W/A	
38	1	317264	PLATE CRUMBER 6 PAINTED	
39	2	13218	BOLT HEX	1/2 X 3-3/4 - UNC - GR 5
40	1	317398	ASSY TRENCHER DRIVESHAFT LF	
40.1	1	317205	SHAFT DRIVE LF W/A	
40.2	2	317289	BRG 55 X 100 SEALED	
40.3	1	317285	RING SNAP EXT 2-5/32 X .078	
40.4	1	317206	HOUSING BEARING LF W/A	
41	1	100810	KEY 5/16 X 1-1/2	
43	1	317284	O-RING 4" ID X 1/16 (-045)	
45	1	400000	MOUNT FRAME TORO MINI W/A	OPTIONAL MOUNT PACKAGE
	1	400001	MOUNT FRAME ASV MINI W/A	OPTIONAL MOUNT PACKAGE
	1	400002	MOUNT FRAME BC MINI W/A	OPTIONAL MOUNT PACKAGE
	1	300283	MOUNT FRAME UNIV MINI W/A	OPTIONAL MOUNT PACKAGE
	1	330622	MOUNT FRAME AVANT MINI W/A	AVANT ADPT MNT PKG 330753
46	6	0167011	NU FLG TOP LOCK 1/2 NC GR 8 YZ	OPTIONAL MOUNT PACKAGE
47	6	15209	BOLT HEX - 1/2 X 1-1/2 - UNC - GR 8	OPTIONAL MOUNT PACKAGE

MINI HYDRAULIC TRENCHER PARTS INFORMATION

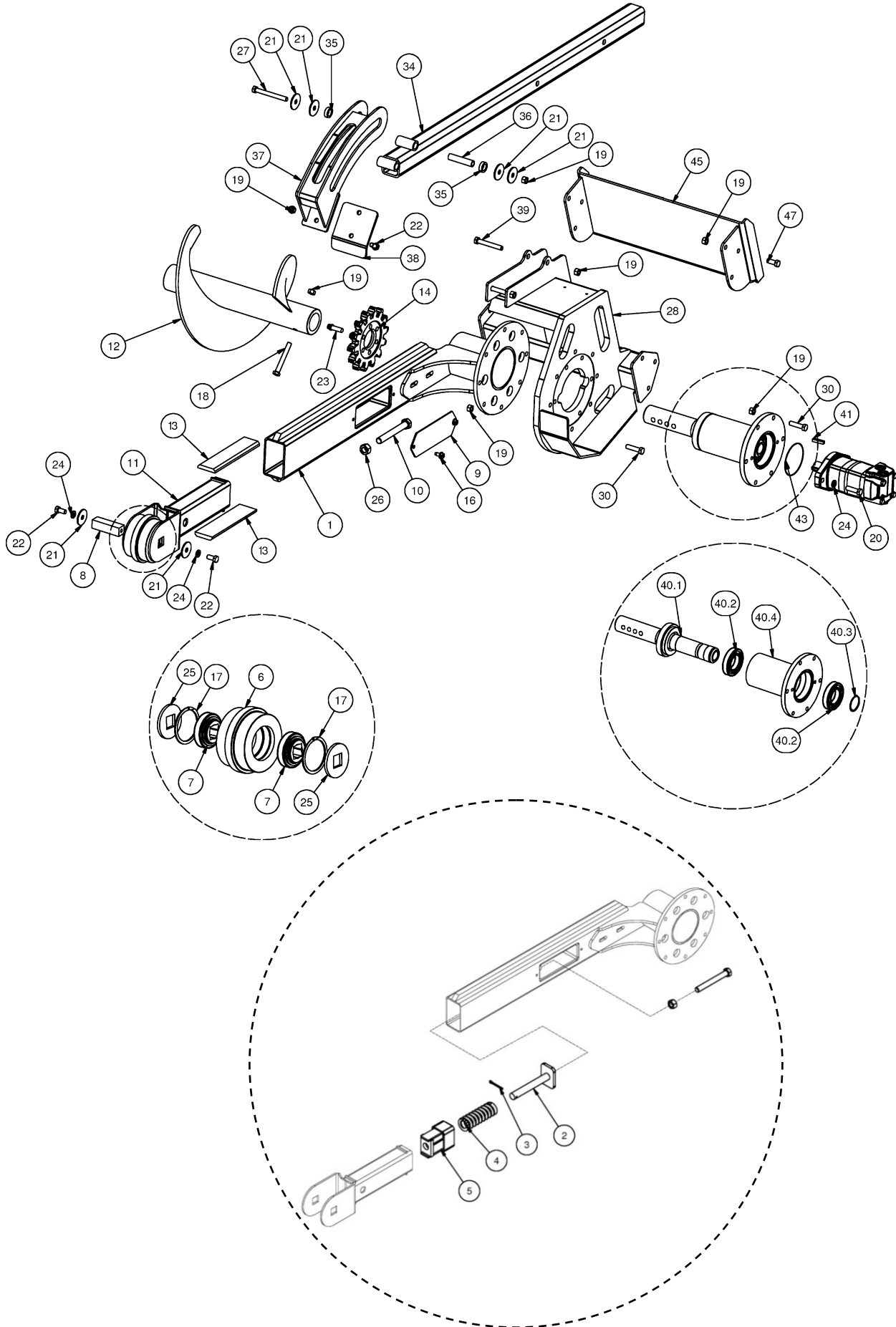

MINI HYDRAULIC TRENCHER PARTS INFORMATION

ITEM	QTY	PART NUMBER	DESCRIPTION	STOCK NUMBER
33	1	317315	MOTOR	
42.3	2	313781	HOSE 1/2 X 65 10MB-8FJX	

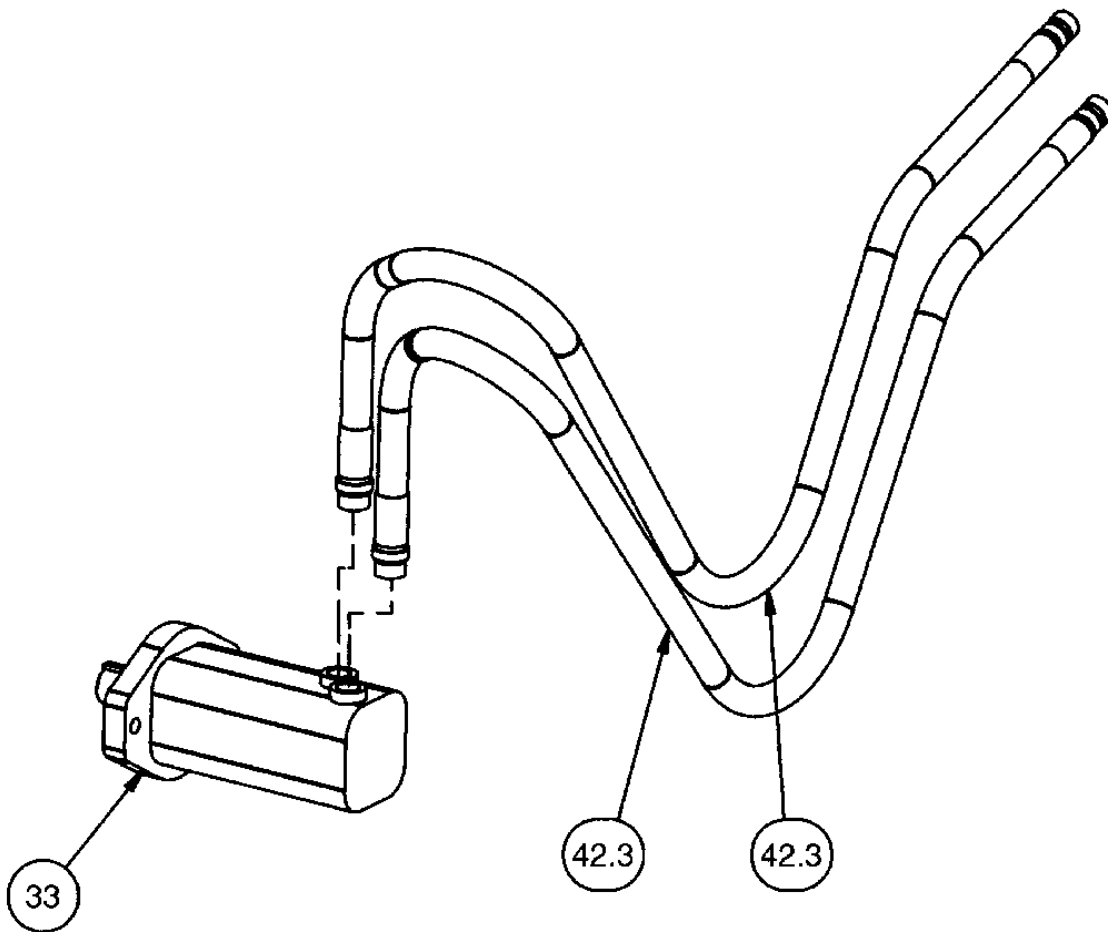

GENERAL SPECIFICATIONS

MODEL	Mini Trencher
OPERATING WEIGHT	600 lbs. approx. (depending on chain type)
OVERALL WIDTH	41"
OVERALL HEIGHT	23"
OVERALL LENGTH	73"
TRENCHING DEPTH (@60 DEGREES)	38"
OPERATING PRESSURE	2000-3000 PSI
RATED FLOW (GPM)	9-15
SHAFT SPEED (RPM)	85-185
STANDARD TEETH	DOUBLE STANDARD CUP

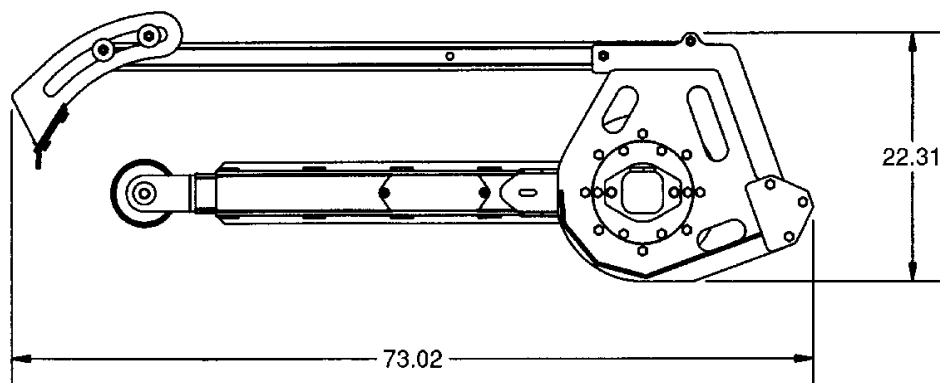
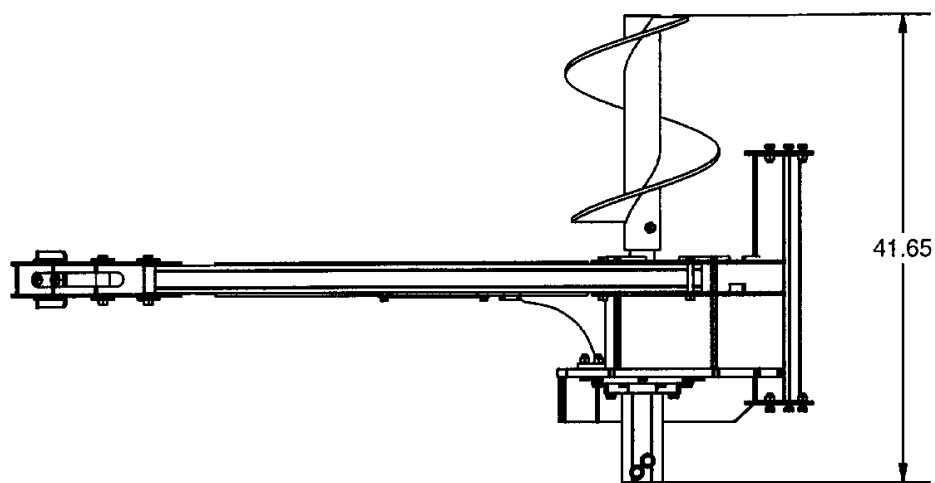

All dimensions are in INCHES.

LIMITED WARRANTY

Spartan Equipment warrants each new machine manufactured by us to be free from defects in material and workmanship for a period of twelve (12) months from date of delivery to the original purchaser.

Our obligation under this warranty is to replace free of charge, at our factory or authorized dealership, any part proven defective within the stated warranty time limit.

All parts must be returned freight prepaid and adequately packaged to prevent damage in transit.

This warranty does not cover:

1. New products which have been operated in excess of rated capacities or negligence
2. Misuse, abuse, accidents or damage due to improperly routed hoses
3. Machines which have been altered, modified or repaired in any manner not authorized by our company
4. Previously owned equipment
5. Any ground engaging tools in which natural wear is involved, i.e. tooth tips, cutting teeth, etc
6. Normal maintenance
7. Fork tines
8. Hydraulic motors that have been disassembled in any manner

In no event will the Sales Representative, Dealership, Spartan Equipment, or any other company affiliated with it or them be liable for incidental or consequential damages or injuries, including but not limited to the loss of profit, rental or substitute equipment or other commercial loss. Purchaser's sole and exclusive remedy being as provided here in above.

Spartan Equipment must receive immediate notification of defect and no allowance will be made for repairs without our consent or approval.

This warranty is in lieu of all other warranties, express or implied by law or otherwise, and there is no warranty of merchantability or fitness purpose.

No agent, employee, or representative of Spartan Equipment has any authority to bind Spartan Equipment to any warranty except as specifically set forth herein. Any of these limitations excluded by local law shall be deemed deleted from this warranty; all other terms apply.

This warranty may not be enlarged or modified in any manner except in writing signed by an executive officer of Spartan Equipment to improve its products whenever it is possible and practical to do so. Spartan Equipment reserves the right to make changes and or add improvements at any time without incurring any obligation to make such changes or add such improvements to products previously sold.

Spartan Equipment
Joppa, MD 21085
1-888-888-1085

P/N 300441 **Date Printed: 12/2/2019**
Spartan Equipment

Printed in U.S.A.