



**SPARTAN
EQUIPMENT®**

INSTALLATION INSTRUCTIONS

FOR

**TILT ATTACH ASSEMBLY #87301
HD TILT ATTACH ASSEMBLY #17446
VALVE KIT #87651
VALVE KIT #88725
VALVE KIT #112921**

INSTRUCTIONS NUMBER: 76136

PREFACE

GENERAL COMMENTS

Congratulations on the purchase of your new SPARTAN EQUIPMENT product! This product was carefully designed and manufactured to give you many years of dependable service. Only minor maintenance (such as cleaning and lubricating) is required to keep it in top working condition. Be sure to observe all maintenance procedures and safety precautions in this manual and on any safety decals located on the product and on any equipment on which the attachment is mounted.

This manual has been designed to help you do a better, safer job. Read this manual carefully and become familiar with its contents.

WARNING! Never let anyone operate this unit without reading the "Safety Precautions" and "Operating Instructions" sections of this manual.



Always choose hard, level ground to park the vehicle on and set the brake so the unit cannot roll.

Unless noted otherwise, right and left sides are determined from the operator's control position when facing the attachment.

NOTE: The illustrations and data used in this manual were current (according to the information available to us) at the time of printing, however, we reserve the right to redesign and change the attachment as may be necessary without notification.

BEFORE OPERATION

The primary responsibility for safety with this equipment falls to the operator. Make sure the equipment is operated only by trained individuals that have read and understand this manual. If there is any portion of this manual or function you do not understand, contact your local authorized dealer or the manufacturer.

SAFETY ALERT SYMBOL



This is the "Safety Alert Symbol" used by this industry. This symbol is used to warn of possible injury. Be sure to read all warnings carefully. They are included for your safety and for the safety of others working with you.

SERVICE

When servicing your product, remember to use only manufacturer replacement parts. Substitute parts may not meet the standards required for safe, dependable operation.

To facilitate parts ordering, record the model and serial number of your unit in the space provided on the cover of this manual. This information may be obtained from the identification plate located on the product.

The parts department needs this information to insure that you receive the correct parts for your specific model.

SAFETY STATEMENTS



THIS SYMBOL BY ITSELF OR WITH A WARNING WORD THROUGHOUT THIS MANUAL IS USED TO CALL YOUR ATTENTION TO INSTRUCTIONS INVOLVING YOUR PERSONAL SAFETY OR THE SAFETY OF OTHERS. FAILURE TO FOLLOW THESE INSTRUCTIONS CAN RESULT IN INJURY OR DEATH.



DANGER

THIS SIGNAL WORD IS USED WHERE SERIOUS INJURY OR DEATH WILL RESULT IF THE INSTRUCTIONS ARE NOT FOLLOWED PROPERLY.



WARNING

THIS SIGNAL WORD IS USED WHERE SERIOUS INJURY OR DEATH COULD RESULT IF THE INSTRUCTIONS ARE NOT FOLLOWED PROPERLY.



CAUTION

THIS SIGNAL WORD IS USED WHERE MINOR INJURY COULD RESULT IF THE INSTRUCTIONS ARE NOT FOLLOWED PROPERLY.



NOTICE

NOTICE INDICATES A PROPERTY DAMAGE MESSAGE.

GENERAL SAFETY PRECAUTIONS

WARNING!

READ MANUAL PRIOR TO INSTALLATION

Improper installation, operation, or maintenance of this equipment could result in serious injury or death. Operators and maintenance personnel should read this manual, as well as all manuals related to this equipment and the prime mover thoroughly before beginning installation, operation, or maintenance. **FOLLOW ALL SAFETY INSTRUCTIONS IN THIS MANUAL AND THE PRIME MOVER'S MANUAL(S).**



READ AND UNDERSTAND ALL SAFETY STATEMENTS

Read all safety decals and safety statements in all manuals prior to operating or working on this equipment. Know and obey all OSHA regulations, local laws, and other professional guidelines for your operation. Know and follow good work practices when assembling, maintaining, repairing, mounting, removing, or operating this equipment.



KNOW YOUR EQUIPMENT

Know your equipment's capabilities, dimensions, and operations before operating. Visually inspect your equipment before you start, and never operate equipment that is not in proper working order with all safety devices intact. Check all hardware to ensure it is tight. Make certain that all locking pins, latches, and connection devices are properly installed and secured. Remove and replace any damaged, fatigued, or excessively worn parts. Make certain all safety decals are in place and are legible. Keep decals clean, and replace them if they become worn or hard to read.



1.

GENERAL SAFETY PRECAUTIONS

WARNING!



PROTECT AGAINST FLYING DEBRIS

Always wear proper safety glasses, goggles, or a face shield when driving pins in or out, or when any operation causes dust, flying debris, or any other hazardous material.

WARNING!



LOWER OR SUPPORT RAISED EQUIPMENT

Do not work under raised booms without supporting them. Do not use support material made of concrete blocks, logs, buckets, barrels, or any other material that could suddenly collapse or shift positions. Make sure support material is solid, not decayed, warped, twisted, or tapered. Lower booms to ground level or on blocks. Lower booms and attachments to the ground before leaving the cab or operator's station.

WARNING!



USE CARE WITH HYDRAULIC FLUID PRESSURE

Hydraulic fluid under pressure can penetrate the skin and cause serious injury or death. Hydraulic leaks under pressure may not be visible. Before connecting or disconnecting hydraulic hoses, read your prime mover's operator's manual for detailed instructions on connecting and disconnecting hydraulic hoses or fittings.

- Keep unprotected body parts, such as face, eyes, and arms as far away as possible from a suspected leak. Flesh injected with hydraulic fluid may develop gangrene or other permanent disabilities.
- If injured by injected fluid, see a doctor at once. If your doctor is not familiar with this type of injury, ask him to research it immediately to determine proper treatment.
- Wear safety glasses, protective clothing, and use a piece of cardboard or wood when searching for hydraulic leaks. **DO NOT USE YOUR HANDS!**
SEE ILLUSTRATION.

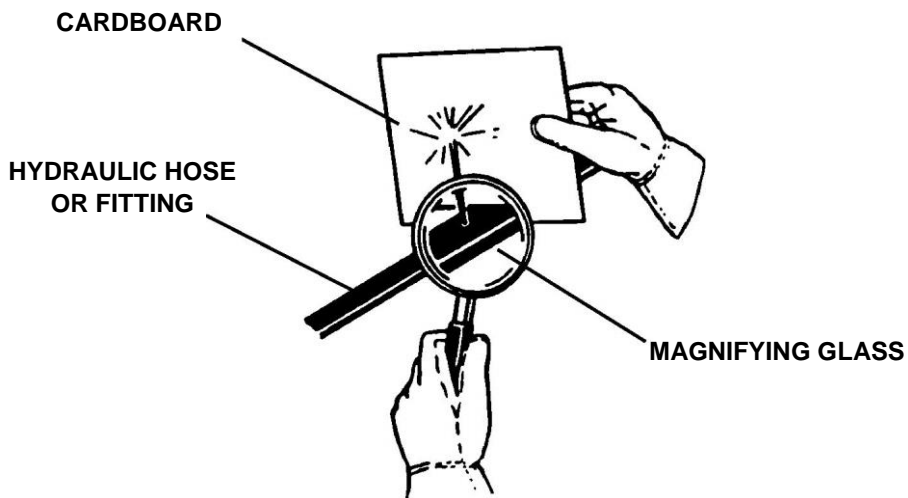

GENERAL SAFETY PRECAUTIONS

WARNING!



DO NOT MODIFY MACHINE OR ATTACHMENTS

Modifications may weaken the integrity of the attachment and may impair the function, safety, life, and performance of the attachment. When making repairs, use only the manufacturer's genuine parts, following authorized instructions. Other parts may be substandard in fit and quality. Never modify any ROPS (Roll Over Protection Structure) or FOPS (Falling Object Protective Structure) equipment or device. Any modifications must be authorized in writing by the manufacturer.

WARNING!



SAFELY MAINTAIN AND REPAIR EQUIPMENT

- Do not wear loose clothing or any accessories that can catch in moving parts. If you have long hair, cover or secure it so that it does not become entangled in the equipment.
- Work on a level surface in a well-lit area.
- Use properly grounded electrical outlets and tools.
- Use the correct tools for the job at hand. Make sure they are in good condition for the task required.
- Wear the protective equipment specified by the tool manufacturer.

SAFELY OPERATE EQUIPMENT



Do not operate equipment until you are completely trained by a qualified operator in how to use the controls, know its capabilities, dimensions, and all safety requirements. See your machine's manual for these instructions.

- Keep all step plates, grab bars, pedals, and controls free of dirt, grease, debris, and oil.
- Never allow anyone to be around the equipment when it is operating.
- Do not allow riders on the attachment or the prime mover.
- Do not operate the equipment from anywhere other than the correct operator's position.
- Never leave equipment unattended with the engine running, or with this attachment in a raised position.
- Do not alter or remove any safety feature from the prime mover or this attachment.
- Know your work site safety rules as well as traffic rules and flow. When in doubt on any safety issue, contact your supervisor or safety coordinator for an explanation.

INSTALLATION AND OPERATION

GENERAL INFORMATION

The SPARTAN EQUIPMENT tilt attach installs onto the toolbar/quick-attach mechanism of your skid steer loader and also attaches to your attachment in the same fashion as a universal quick attach. Due to this arrangement, thorough knowledge of the skid steer controls is necessary for machine operation. Read and understand your skid steer operator's manual instructions for attaching and detaching an attachment.

INSTALLATION INSTRUCTIONS

2. Remove the shipping banding from around the tilt attach and skid.
3. Remove any attachments from the front of the loader.
4. Following all standard safety practices and the instructions for installing an attachment in your skid steer operator's manual, install the tilt attach onto your skid steer.

NOTE: It is important to make sure the locking mechanism on your quick attach is engaged, therefore locking the tilt attach onto the skid steer.

4. Lower the loader arms to the ground and remove the key.
5. Relieve any pressure from the auxiliary hydraulic system and install your hose kit to the elbows on the top of the tilt attach and to the loader auxiliary hydraulics. If operating an attachment (such as a bucket) that does not require hydraulics your tilt attach is ready to accept the attachment.
6. Install the desired attachment to your tilt attach following the attachment manuals recommendations.

WARNING! ALWAYS CHECK LOCKING MECHANISM (PINS) BEFORE TILTING OR OPERATING ANY ATTACHMENT.



If installing an attachment to your tilt attach that requires auxiliary hydraulics install one of the valve kit packages.

POSTMASTER VALVE INSTALLATION (Refer to the diagram and parts list in the back of instructions.)

1. Install valve mounting bracket to the top of the tilt attach using the .38" hardware supplied. Secure the valve #2243 to the bracket using the .31" hardware supplied and install the hose loop to the side of the tilt attach by removing one of the .50" X 1.00" capscrews from the left side and replacing with the 1.25" capscrew supplied.
2. Install elbows #3430 to the existing elbows on the tilt attach followed by the 45° end of the 16.5" hose and the 21" hose. Install straight adapters #62208 to the middle ports of the valve and connect the 90° ends of the hoses coming from the tilt attach.
3. Install elbows #3283 to the right side ports in the valve and straight adapters #3324 to the left ports of the valve.
4. Remove the power and return hoses from the postmaster and install them into the straight adapters installed in step #8. Route hoses through the hose loop and up to the auxiliary hydraulics on the loader.

INSTALLATION AND OPERATION

5. Install the two 30" hoses to the remaining elbows in the valve followed by the two #3133 elbows. Connect these to the post master in the same location the power and return hoses were removed. Check all connections for leaks.

PD4800 POST DRIVER VALVE INSTALLATION (Refer to the diagram and parts list in the back of instructions.)

1. Install valve mounting bracket to the top of the tilt attach using the .38" hardware supplied. Secure the valve #2243 to the bracket using the .31" hardware supplied and install the hose loop to the side of the tilt attach by removing one of the .50" X 1.00" capscrews from the left side and replacing with the 1.25" capscrew supplied.
2. Install elbows #3430 to the existing elbows on the tilt attach followed by the 45° end of the 16.5" hose and the 21" hose. Install straight adapters #62208 to the middle ports of the valve and connect the 90° ends of the hoses coming from the tilt attach.
3. Install straight connectors #30298 and #30289 to the right side ports in the valve followed by one set of couplers, and straight adapters #3270 to the left ports of the valve.
4. Connect the power and return hoses from the post driver to the couplers installed in Step #3. Connect the 80" long hoses #35379 to the connectors on the left ports of the valve followed by the remaining couplers. Route hoses through the hose loop and up to the auxiliary hydraulics on the loader. Check all connections for leaks.

UNIVERSAL VALVE INSTALLATION (Refer to the diagram and parts list in the back of instructions.)

1. Install valve mounting bracket to the top of the tilt attach using the .38" hardware supplied. Secure the valve #2243 to the bracket using the .31" hardware supplied and install the hose loop to the side of the tilt attach by removing one of the .50" X 1.00" capscrews from the left side and replacing with the 1.25" capscrew supplied.
2. Install the 45° end of the 16.5" hose and the 21" hose to the elbows on the tilt attach. Install straight adapters #62208 to the middle ports of the valve and connect the 90° ends of the hoses coming from the tilt attach.
3. Install elbows #3283 to the right side ports in the valve.
4. Connect the electrical wiring on the diverter valve to the auxiliary electrical connector on the skid steer loader or to the optional Spartan Equipment control box.

NOTE: The hoses going to the attachment will attach to right side ports of the valve. Attach hoses going to the loader auxiliary hydraulics to the left side ports of the diverter valve. Work with your local dealer to obtain appropriate hoses necessary to complete the hydraulic circuit for the desired attachment hook-up.

WARNING! ALWAYS CHECK LOCKING MECHANISM (PINS) BEFORE TILTING OR OPERATING ANY ATTACHMENT.



MAINTENANCE & SERVICE

GENERAL INFORMATION

Regular maintenance is the key to long equipment life and safe operation. Maintenance requirements have been reduced to the absolute minimum. However, it is very important that these maintenance functions be performed as described below.

DAILY

- Check all bolts and nuts for tightness.
- Replace any missing bolts or nuts with approved replacement parts.
- Check hydraulic system for hydraulic oil leaks. See procedure below.
- Visually inspect the machine for worn parts or cracked welds, and repair as necessary.

EVERY 40 HOURS

- Lubricate all grease fittings.

WARNING! Escaping fluid under pressure can have sufficient force to penetrate the skin, causing serious personal injury. Fluid escaping from a very small hole can be almost invisible. Use a piece of cardboard or wood, rather than hands, to search for suspected leaks.



Keep unprotected body parts, such as face, eyes, and arms as far away as possible from a suspected leak. Flesh injected with hydraulic fluid may develop gangrene or other permanent disabilities.

If injured by injected fluid, see a doctor at once. If your doctor is not familiar with this type of injury, ask him to research it immediately to determine proper treatment.

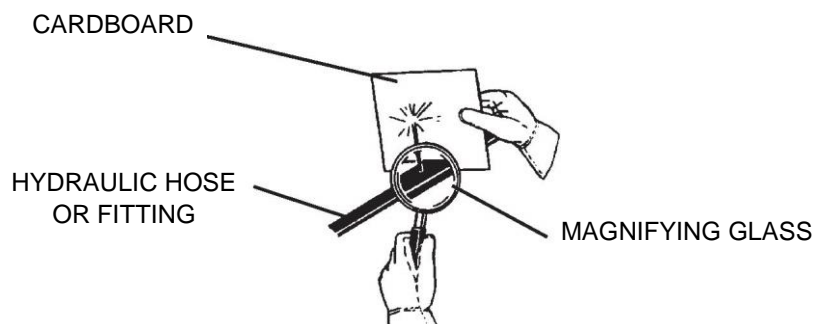

IMPORTANT: When replacing parts, use only factory approved replacement parts. Manufacturer will not claim responsibility for use of unapproved parts or accessories, and/or other damages as a result of their use.

MAINTENANCE AND SERVICE

8.

CYLINDER SEAL REPLACEMENT

The following information is provided to assist you in the event you should need to repair or rebuild a hydraulic cylinder. When working on hydraulic cylinders, make sure that the work area and tools are clean and free of dirt to prevent contamination of the hydraulic system and damage to the hydraulic cylinders. Always protect the active part of the cylinder rod (the chrome section). Nicks or scratches on the surface of the rod could result in cylinder failure. Clean all parts thoroughly with a cleaning solvent before reassembly.

DISASSEMBLY PROCEDURE

IMPORTANT: Do not contact the active surface of the cylinder rod with the vise. Damage to the rod could result.

THREADED TYPE GLAND

1. Rotate the gland with a spanner wrench counterclockwise until the gland is free of the cylinder tube.
2. Pull the cylinder rod from the cylinder tube and inspect the piston and the bore of the cylinder tube for deep scratches or galling. If damaged, the piston AND the cylinder tube must be replaced.

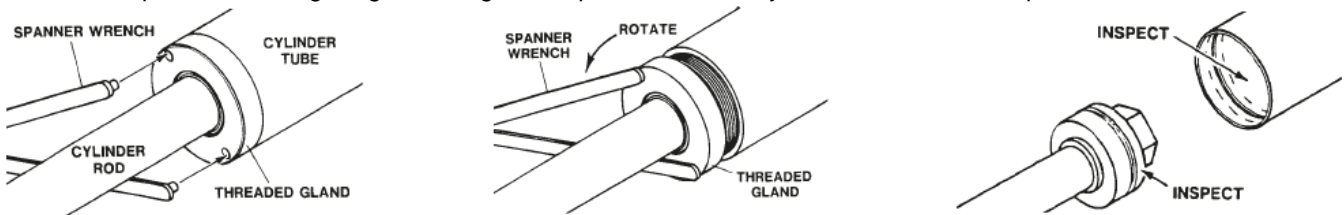

3. Remove the hex nut, piston, flat washer or spacer tube (if so equipped), and gland from the cylinder rod. If the cylinder rod is rusty, scratched, or bent, it must be replaced.
4. Remove and discard all the old seals.

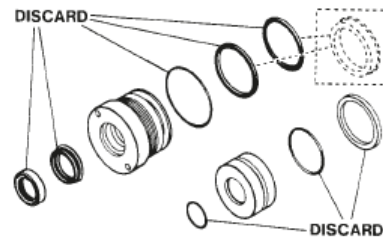
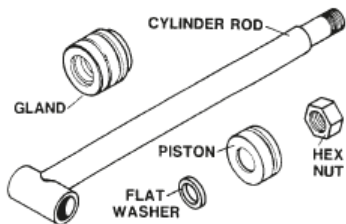

ASSEMBLY PROCEDURE

IMPORTANT: Replace all seals even if they do not appear to be damaged. Failure to replace all seals may result in premature cylinder failure. NOTE: Seal kits will service most cylinders of similar bore size and rod diameter.

1. Install the cylinder rod seal in the gland first. Be careful not to damage the seal in the process, as it is somewhat difficult to install.

NOTE: A special installation tool (Part #65349) is available to help with installing the seal. Simply fit the end of the tool over the seal so that the large prong of the tool is on the outside of the seal, and the two smaller prongs on the inside. The lip of the seal should be facing towards the tool. Rotate the handles on the tool around to wrap the seal around the end of the tool.

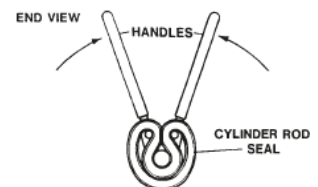
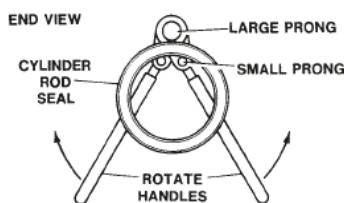
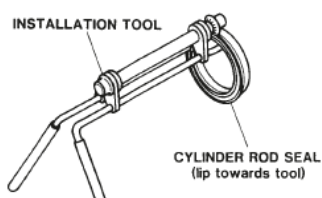

MAINTENANCE AND SERVICE

10.

Now insert the seal into the gland from the inner end. Position the seal in its groove, and release and remove the tool. Press the seal into its seat the rest of the way by hand.

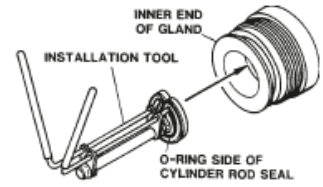

- Install the new piston ring, rod wiper, O-rings and backup washers, if applicable, on the piston.

Be careful not to damage the seals. Caution must be used when installing the piston ring. The ring must be stretched carefully over the piston with a smooth, round, pointed tool.

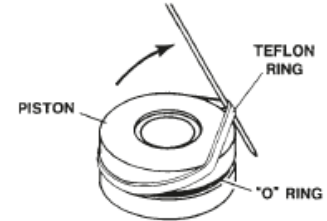

- After installing the rod seal inside the gland, as shown in step #1, install the external seal.

NOTE: Threaded glands may have been equipped with a separate O-ring and backup washer system or a polypak (all in one) type seal. Current seal kits contain a polypak (all in one) type seal to replace the discarded seal types on ALL THREADED GLANDS.

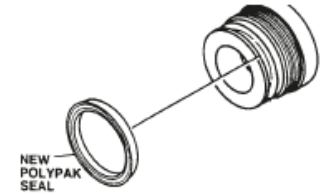

- Slide the gland onto the cylinder rod, being careful not to damage the rod wiper. Then install the spacer, or flat washer (if so equipped), small o-ring, piston, and hex nut onto the end of the cylinder rod.
- Secure the cylinder rod (mounting end) in a vise with a support at its center. Torque the nut to the amount shown for the thread diameter of the cylinder rod (see chart).

Thread Diameter	POUNDS - FEET
7/8"	150-200
*1"	230-325
1-1/8"	350-480
1-1/4"	490-670
1-3/8"	670-900
* 1" Thread Diameter WITH 1.25" Rod Diameter	
	Min. 230 ft. lbs. Max. 250 ft. lbs.

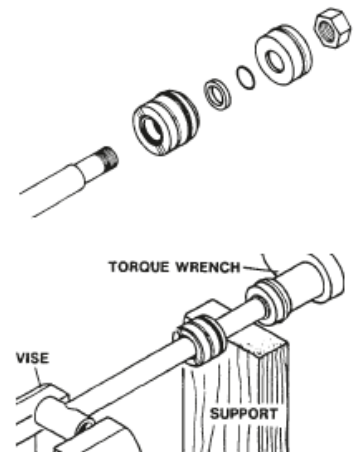

IMPORTANT: Do not contact the active surface of the cylinder rod with the vise. Damage to the rod could result.

- Apply a lubricant (such as Lubriplate #105) to the piston and teflon ring. Insert the cylinder rod assembly into the cylinder tube.

IMPORTANT: Ensure that the piston ring fits squarely into the cylinder tube and piston groove, otherwise the ring may be damaged and a leak will occur.

- Use a spanner wrench to rotate the gland clockwise into the cylinder. Continue to rotate the gland with the spanner wrench until it is tight.

WARNING!



Cylinders serviced in the field are to be tested for leakage prior to the attachment being placed in work. Failure to test rebuilt cylinders could result in damage to the cylinder and/or the attachment, cause severe personal injury or even death.







BOLT TORQUE

BOLT TORQUE SPECIFICATIONS

GENERAL TORQUE SPECIFICATION TABLE

Use the following torques when special torques are not given. These values apply to fasteners as received from suppliers, dry, or when lubricated with normal engine oil. They do not apply if special graphited or moly disulphide greases or other extreme pressure lubricants are used. This applies to both UNF and UNC threads. Remember to always use grade five or better when replacing bolts.

IMPORTANT: On all PLATED GRADE 8 bolts, reduce torque 15 from listed bolt torque specification.

SAE Grade No.		2				5				8*			
Bolt head identification marks as per grade. NOTE: Manufacturing Marks Will Vary						  				  			
		TORQUE		TORQUE		TORQUE		TORQUE		TORQUE		TORQUE	
Bolt Size Inches	Millimeters	Pounds Feet		Newton-Meters		Pounds Feet		Newton-Meters		Pounds Feet		Newton-Meters	
		Min.	Max.	Min.	Max.	Min.	Max.	Min.	Max.	Min.	Max.	Min.	Max.
1/4	6.35	5	6	7	8	9	11	12	15	12	15	16	20
5/16	7.94	10	12	14	16	17	20.5	23	28	24	29	33	39
3/8	9.53	20	23	27	31	35	42	48	57	45	54	61	73
7/16	11.11	30	35	41	47	54	64	73	87	70	84	95	114
1/2	12.70	45	52	61	70	80	96	109	130	110	132	149	179
9/16	14.29	65	75	88	102	110	132	149	179	160	192	217	260
5/8	15.88	95	105	129	142	150	180	203	244	220	264	298	358
3/4	19.05	150	185	203	251	270	324	366	439	380	456	515	618
7/8	22.23	160	200	217	271	400	480	542	651	600	720	814	976
1	25.40	250	300	339	406	580	696	787	944	900	1080	1220	1464
1-1/8	25.58	-	-	-	-	800	880	1085	1193	1280	1440	1736	1953
1-1/4	31.75	-	-	-	-	1120	1240	1519	1681	1820	2000	2468	2712
1-3/8	34.93	-	-	-	-	1460	1680	1980	2278	2380	2720	3227	3688
1-1/2	38.10	-	-	-	-	1940	2200	2631	2983	3160	3560	4285	4827

* Thick Nuts must be used with Grade 8 bolts

METRIC BOLT TORQUE SPECIFICATIONS

Size of Screw	Grade No.	Coarse Thread			Fine Thread		
		Pitch (mm)	Pounds Feet	Newton-Meters	Pitch (mm)	Pounds Feet	Newton-Meters
M6	5.6	1.0	3.6-5.8	4.9-7.9	-	-	-
	8.8		5.8-4	7.9-12.7		-	-
	10.9		7.2-10	9.8-13.6		-	-
M8	5.6	1.25	7.2-14	9.8-19	1.0	12-17	16.3-23
	8.8		17-22	23-29.8		19-27	25.7-36.6
	10.9		20-26	27.1-35.2		22-31	29.8-42
M10	5.6	1.5	20-25	27.1-33.9	1.25	20-29	27.1-39.3
	8.8		34-40	46.1-54.2		35-47	47.4-63.7
	10.9		38-46	51.5-62.3		40-52	54.2-70.5
M12	5.6	1.75	28-34	37.9-46.1	1.25	31-41	42-55.6
	8.8		51-59	69.1-79.9		56-68	75.9-92.1
	10.9		57-66	77.2-89.4		62-75	84-101.6
M14	5.6	2.0	49-56	66.4-75.9	1.5	52-64	70.5-86.7
	8.8		81-93	109.8-126		90-106	122-143.6
	10.9		96-109	130.1-147.7		107-124	145-168
M16	5.6	2.0	67-77	90.8-104.3	1.5	69-83	93.5-112.5
	8.8		116-130	157.2-176.2		120-138	162.6-187
	10.9		129-145	174.8-196.5		140-158	189.7-214.1
M18	5.6	2.0	88-100	119.2-136	1.5	100-117	136-158.5
	8.8		150-168	203.3-227.6		177-199	239.8-269.6
	10.9		175-194	237.1-262.9		202-231	273.7-313
M20	5.6	2.5	108-130	146.3-176.2	1.5	132-150	178.9-203.3
	8.8		186-205	252-277.8		206-242	279.1-327.9
	10.9		213-249	288.6-337.4		246-289	333.3-391.6

12.

MOUNTING KIT INSTALLATION

HEAVY DUTY TILT ATTACH ASSEMBLY #17446

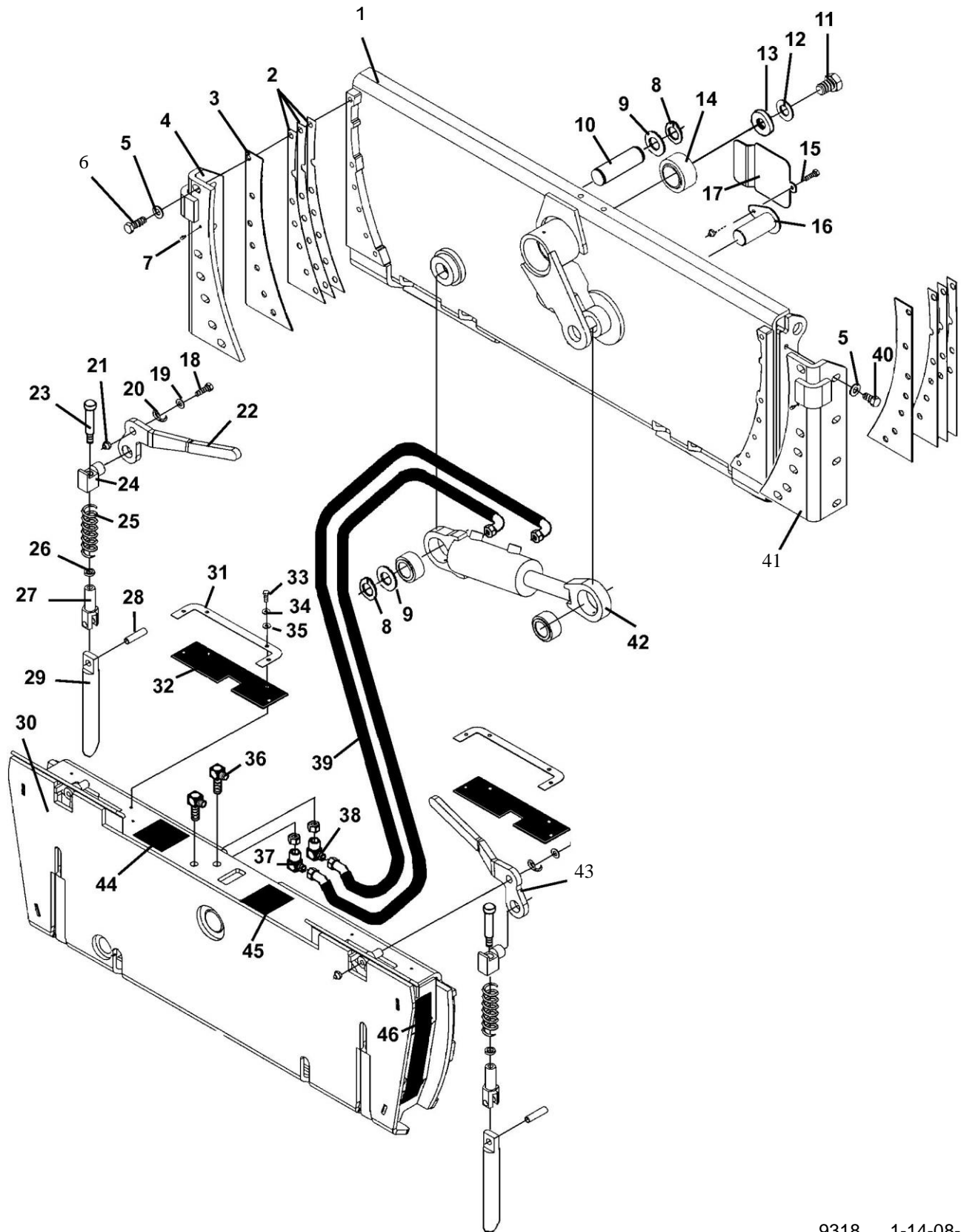

MOUNTING KIT INSTALLATION

HEAVY DUTY TILT ATTACH ASSEMBLY #17446

<u>ITEM</u>	<u>REQ'D</u>	<u>PART NO.</u>	<u>DESCRIPTION</u>
1	1	17447	Rear Frame
	1	6616	Grease Fitting
2	6	17495	Shim
3	2	17465	Shim
4	1	18096	Right Angle Retainer
5	20	1646	.50" Hard Flat Washer
6	12	1090	.50" UNC X 1.50" Hex Capscrew
7	2	53031	90° Grease Fitting
8	2	1650	Snap Ring
9	2	64725	Thrust Washer
10	1	86608	Cylinder Pin
11	1	1160	.88" UNC X 1.50" Hex Capscrew
12	1	1845	.88" Hard Flat Washer
13	1	18684	Spacer Tube
14	1	86885	Self Aligning Bushing
15	1	1022	.31" UNC X 1.00" Hex Capscrew
16	1	17467	Cylinder Pin
17	1	105873	Cover
18	2	1050	.38" UNC X 2.75" Hex Capscrew
19	2	1514	.38" Flat Washer
20	2	87333	Lock Handle Spring
21	2	1536	.38" UNC Nylock Nut
22	1	87342	Right Lock Handle
23	2	87335	Shoulder Bolt
24	2	87330	Bearing End Lock Pin
25	2	87334	Clevis Spring
26	As Req'd	33056	Spacer Tube
27	2	87329	Clevis
28	2	87337	Roll Pin
29	2	87328	Locking Pin
30	1	17448	Front Frame
	3	6616	Grease Fitting
31	2	89169	Clamp Plate
32	2	89168	Lever Flap
33	8	1002	.25" UNC X .75" Hex Capscrew
34	8	1501	.25" Lock Washer
35	8	1512	.25" Flat Washer
36	2	3282	90° Bulkhead Fitting 6MJ-6MJ
37	1	3430	90° Adapter 6FJX-6MJ
38	1	30197	90° Adapter 6FJX-6MJ with Restrictor
39	2	37734	Hose .25" x 16.25" 90° 6FJX - 45° 6FJX
40	8	1088	.50" UNC X 1.00" Hex Capscrew
41	1	18095	Left Angle Retainer
42	1	87332	Cylinder Assembly
	2	6615	Self Aligning Bushing
	2	87336	Tube Sleeve
	1	53031	90° Grease Fitting
	1	84688	45° Grease Fitting
43	1	87331	Left Lock Handle
44	1	40151	Decal, Warning High Pressure Fluid
45	1	40397	Decal, Do Not Mount Backhoe
46	2	40179	Decal, BRADCO Logo

13.

MOUNTING KIT INSTALLATION

TILT ATTACH ASSEMBLY #87301

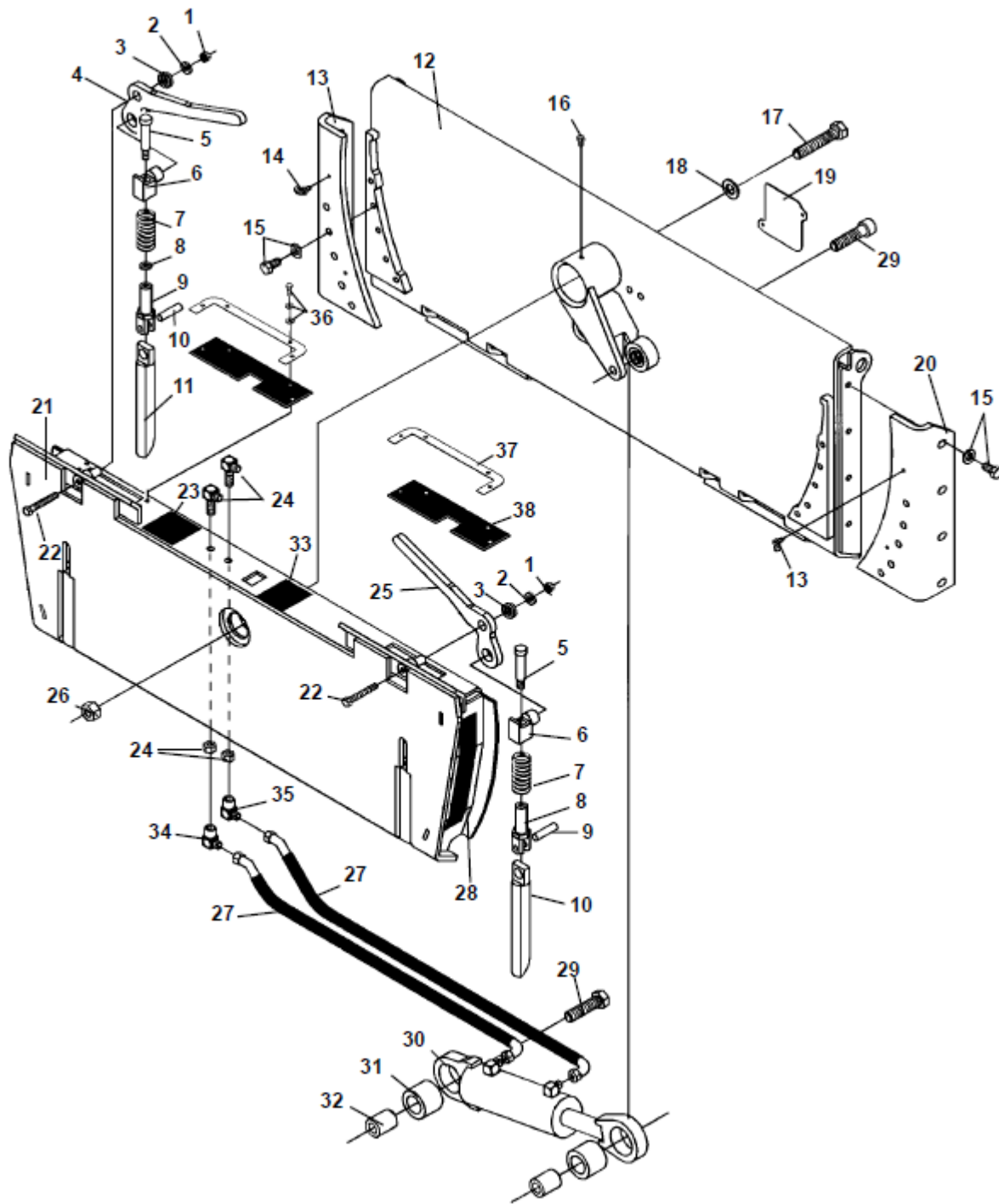

MOUNTING KIT INSTALLATION

TILT ATTACH ASSEMBLY #87301

<u>ITEM</u>	<u>REQ'D</u>	<u>PART NO.</u>	<u>DESCRIPTION</u>
1	2	1536	.38" UNC Lock Nut
2	2	1514	.38" Flat Washer
3	2	87333	Lock Handle Spring
4	1	87342	Right Lock Handle
5	2	87335	Step Bolt
6	2	87330	Bearing End Lock Pin
7	2	87334	Clevis Spring
8	4	33056	Spacer
9	2	87329	Clevis
10	2	87337	Roll Pin
11	2	87328	Lock Pin
12	1	87302	Rear Frame
13	1	87341	Right Retainer Angle
14	2	53031	90° Grease Zerk
15	18	1646	.50" Hard Flat Washer
	18	1088	.50" UNC X 1.00" Hex Capscrew
16	1	6616	Grease Zerk
17	1	1147	.75" UNC X 4.00" Hex Capscrew
18	1	1649	.75" Hard Flat Washer
19	1	105874	Cover
	2	1021	.31" UNC X .75" Hex Capscrew
	2	1502	.31" Lock Washer
20	1	87327	Left Retainer Angle
21	1	87312	Front Tilt Frame
22	2	1050	.38" UNC X 2.75" Hex Capscrew
23	1	40151	High Pressure Fluid Hazard Decal
24	2	3282	90° Bulkhead Fitting 6MJ - 6MJ
25	1	87331	Left Lock Handle
26	1	1231	.75" UNC Hex Nut
27	2	37734	Hose .25" X 16.25" 45° 6FJX - 90° 6FJX
28	2	40179	BRADCO Logo Decal
29	2	10060	.75" UNC X 3.00" Hex Capscrew - Grade 8
30	1	87332	Tilt Cylinder Assembly
	1	53031	90° Grease Zerk
	1	84688	45° Grease Zerk
31	2	6615	Bushing (Included in Cylinder Assembly)
32	2	87336	Tube Sleeve
33	1	40397	Decal - Do Not Mount Backhoe
34	1	3430	90° Adapter 6FJX-6MJ
35	1	30197	90° Adapter 6FJX-6MJ with Restrictor
36	8	1002	.25" UNC X .75" Hex Capscrew
	8	1501	.25" Lock Washer
	8	1512	.25" Flat Washer
37	2	89169	Clamp Plate
38	2	89168	Lever Flap

7867 1-14-08-3

CYLINDER ASSEMBLY^{14.}
ASSEMBLY #87332

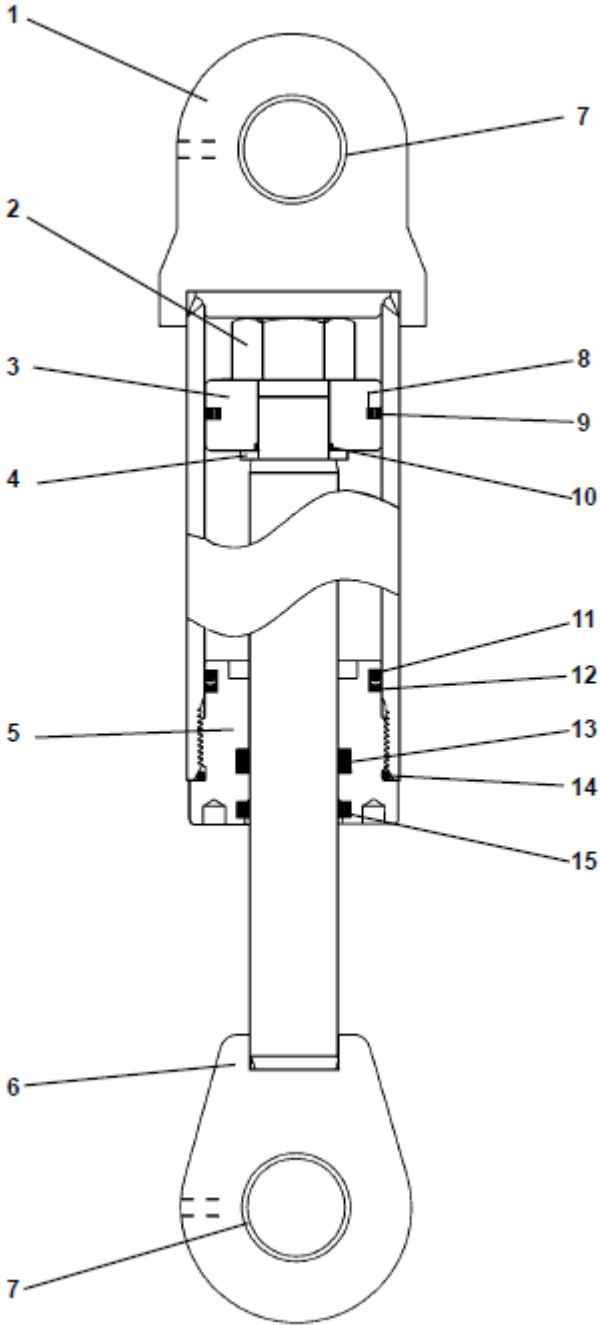

CYLINDER ASSEMBLY

ASSEMBLY #87332

<u>ITEM</u>	<u>REQ'D</u>	<u>PART NO.</u>	<u>DESCRIPTION</u>
1	1	87345	Cylinder Tube
2	1	1483	Hex Nut (Torque to 230-250 Ft. Lbs.)
3	1	50252	Piston
4	1	5421	Washer
5	1	77458	Cylinder Gland
6	1	87347	Self-Aligning Bushing
7	2	6615	Cylinder Rod
8	1	4645*	O'Ring
9	1	4644*	Piston Ring
10	1	4641*	O'Ring
11	1	4509*	O'Ring
12	1	4510*	Back-Up Washer
13	1	45219*	Poly-Pak Seal
14	1	45250*	O'Ring
15	1	45389*	Rod Wiper

NOTE: Seal Kit #45617 includes all parts marked with an asterisk (*). Parts are not sold separately.

MOUNTING KIT INSTALLATION

VALVE KIT #87651

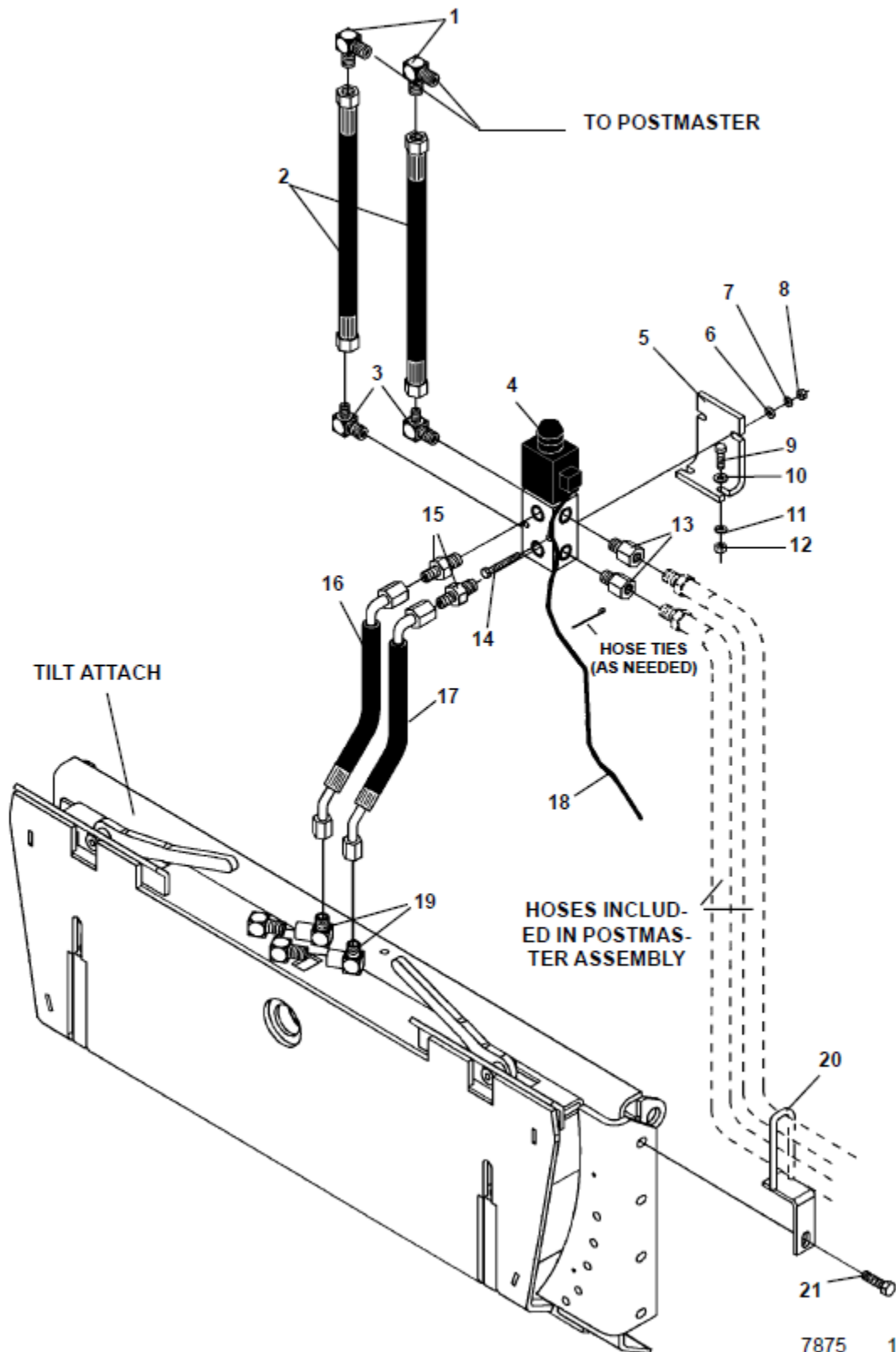

MOUNTING KIT INSTALLATION

VALVE KIT #87651

<u>ITEM</u>	<u>REQ'D</u>	<u>PART NO.</u>	<u>DESCRIPTION</u>
1	2	3133	90° Adapter 8MP-8FP
2	2	35129	Hose Assembly .50" X 30" 8MP-8FJX-HS
3	2	3283	90° Adapter 8MJ-10MBo
4	1	2243	6-Way Diverter Valve
5	1	87655	Valve Mounting Plate
6	2	1513	.31" Flat Washer
7	2	1502	.31" Lock Washer
8	2	1225	.31" UNC Hex Nut
9	2	1044	.38" UNC X 1.25" Hex Capscrew
10	2	1514	.38" Flat Washer
11	2	1503	.38" Lock Washer
12	2	1226	.38" UNC Hex Nut
13	2	3324	Straight Adapter 8FP-10MBo
14	2	1032	.31" UNC X 3.50" Hex Capscrew
15	2	62208	Straight Adapter 6MJ-10Bo with Restrictor
16	1	37734	Hose .25" X 16.5 " 45° 6FJX - 90° 6FJX
17	1	37735	Hose .25" X 21" 45° 6FJX - 90° 6FJX
18	1	88626	Wire Assembly
19	2	3430	90° Adapter 6FJX-6MJ
20	1	87652	Hose Loop
21	1	1089	.50" UNC X 1.25" Hex Capscrew

16.

MOUNTING KIT INSTALLATION

VALVE KIT #88725

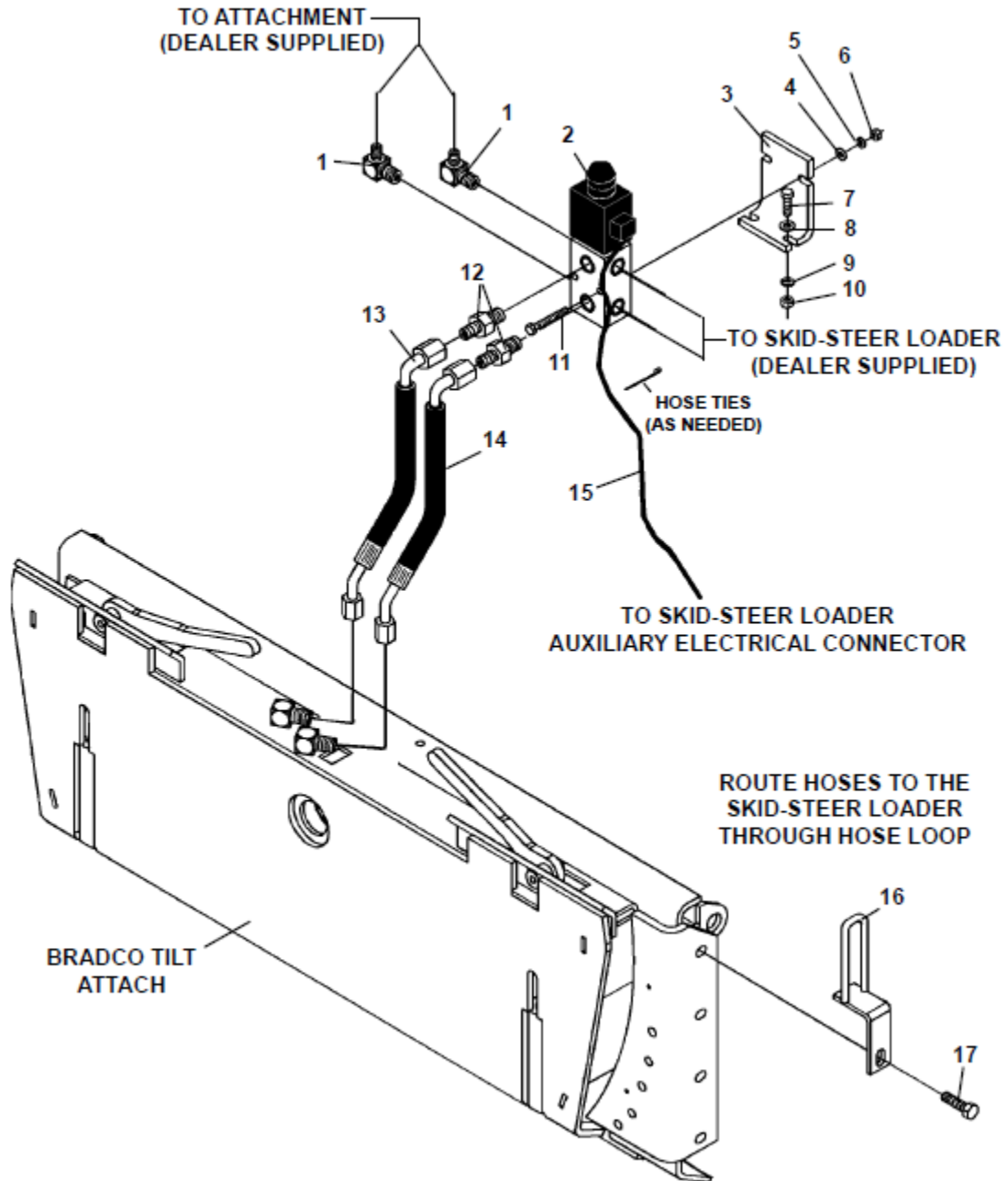

MOUNTING KIT INSTALLATION

VALVE KIT #88725

<u>ITEM</u>	<u>REQ'D</u>	<u>PART NO.</u>	<u>DESCRIPTION</u>
1	2	3283	90° Adapter 8MJ-10MBo
2	1	2243	6-Way Diverter Valve
3	1	87655	Valve Mounting Plate
4	2	1513	.31" Flat Washer
5	2	1502	.31" Lock Washer
6	2	1225	.31" UNC Hex Nut
7	2	1044	.38" UNC X 1.25" Hex Capscrew
8	2	1514	.38" Flat Washer
9	2	1503	.38" Lock Washer
10	2	1226	.38" UNC Hex Nut
11	2	1032	.31" UNC X 3.50" Hex Capscrew
12	2	62208	Straight Adapter 6MJ-10MBo w/Restrictor
13	1	37734	Hose .25" X 16.5" 45° 6FJX - 90° 6FJX
14	1	37735	Hose .25" X 21" 45° 6FJX - 90° 6FJX
15	1	88626	Wire Assembly
16	1	87652	Hose Loop
17	1	1089	.50" UNC X 1.25" Hex Capscrew

VALVE KIT

ASSEMBLY #112921

(FOR MOUNTING THE PD4800 POST DRIVER TO A BRADCO TILT ATTACH)

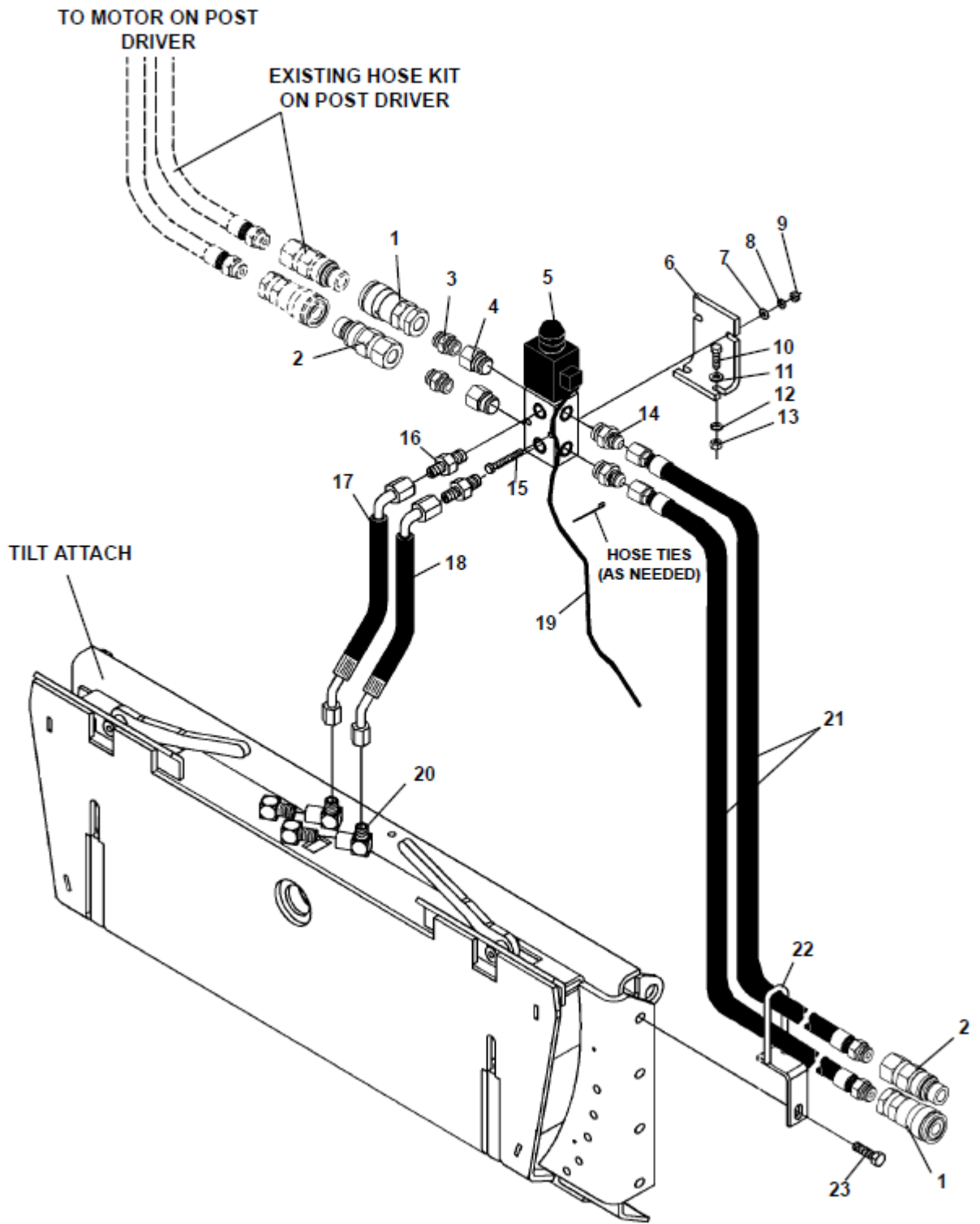

VALVE KIT

ASSEMBLY #112921

(FOR MOUNTING THE PD4800 POST DRIVER TOA SPARTAN EQUIPMENT
TILT ATTACH)

<u>ITEM</u>	<u>REQ'D</u>	<u>PART NO.</u>	<u>DESCRIPTION</u>
1	2	14175	Female Coupler 8FBo .50" Body
2	2	19628	Male Coupler 8FBo .50" Body
3	2	30289	Straight Connector 8MBo-8MBo
4	2	30298	Straight Connector 10MBo-8FBo
5	1	2243	Diverter Valve
6	1	87655	6-Way Valve Mounting Plate
7	2	1513	.31" Flat Washer
8	2	1502	.31" Lock Washer
9	2	1225	.31" UNC Hex Nut
10	2	1044	.38" UNC X 1.25" Hex Capscrew
11	2	1514	.38" Flat Washer
12	2	1503	.38" Lock Washer
13	2	1226	.38" UNC Hex Nut
14	2	3270	Straight Connector 10MBo-8MJ
15	2	1032	.31" UNC X 3.50" Hex Capscrew
16	2	62208	Straight Connector 6MJ-10MBo With .060 Dia. Orifice
17	1	37734	Hose .25" X 16.50" 6FJX 45° - 6FJX 90°
18	1	37735	Hose .25" X 21" 6FJX 45° - 6FJX 90°
19	2	88626	Wire Assembly
20	2	3430	90° Adapter 6FJX-6MJ
21	2	35379	Hose Assembly .50" X 80" 8MBo-8FJX
22	1	87652	Hose Loop
23	1	1089	.31" UNC X 3.50" Hex Capscrew