



**SPARTAN
EQUIPMENT®**

OPERATOR'S AND PARTS MANUAL

3K2 EARTH AUGER



SERIAL NUMBER:

Manual Number: 24523

MODEL NUMBER:

Date: May 16, 2005

TO THE OWNER

GENERAL COMMENTS

Congratulations on the purchase of your new Spartan Earth Auger Attachment. Your earth auger was carefully designed and manufactured to give you many years of dependable service. Your earth auger will require some minor maintenance (such as cleaning and lubricating) to keep it in top working condition. Be sure to observe all maintenance procedures and safety precautions in this manual, on the safety decals located on the attachment, and on any equipment on which the earth auger is mounted.

ABOUT THIS MANUAL

This manual has been designed to help you to do a better, safer job. Read this manual carefully, and become familiar with the operating procedures before attempting to operate your earth auger. Remember, never let anyone operate this earth auger without them having read and completely understand the "Safety Precaution" and "Operating Instructions" sections of this manual, or having them be fully trained by an experienced, qualified person who has read and completely understands the "Safety Precautions" and Operating Instructions".

After reading this manual, if you have any questions about your attachment please contact us immediately as follows:

NORTH AMERICAN TOLL FREE: 1.888.888.1085

SERVICE

When servicing this product, remember to use only manufacturer replacement parts. Substitute parts may not meet the standards required for safe, dependable operation.

To facilitate parts ordering, record the model and serial number of your unit in the space provided on this page. This information may be obtained from the identification plate located on the product.

MODEL: _____ SERIAL NO. _____

Your parts department needs this information to insure that you receive the correct parts or attachments for your specific earth auger.

M-102 4-18-05-4

**THIS PAGE
IS INTENTIONALLY
BLANK**

TABLE OF CONTENTS

Letter To The Owner	1
Safety Statements	4
General Precautions	4-6
Equipment Safety Precautions	7
Electric Select Auger Assembly Exploded View and Parts List	8-9
Manual Select Auger Assembly Exploded View and Parts List	10-11
Quick Attach Mounting Assemblies - Exploded View and Parts List	12-13
Backhoe & Excavator Mounting Assemblies - Exploded View and Parts List	14-15
Universal Front End Loader Mounting Assembly #21235 - Exploded View and Parts List	16-17
Mounting & Installation Instructions	18-19
Hydraulic System Hook-up Instructions	20
Operating Instructions	21
Maintenance Instructions	22-24
Troubleshooting	25
Drive Unit Specifications	26
Auger Parts List	27
Warranty	28

**THIS PAGE
IS INTENTIONALLY
BLANK**

SAFETY STATEMENTS



THIS SYMBOL BY ITSELF OR WITH A WARNING WORD THROUGHOUT THIS MANUAL IS USED TO CALL YOUR ATTENTION TO INSTRUCTIONS INVOLVING YOUR PERSONAL SAFETY OR THE SAFETY OF OTHERS. FAILURE TO FOLLOW THESE INSTRUCTIONS CAN RESULT IN INJURY OR DEATH.

DANGER

THIS SIGNAL WORD IS USED WHERE SERIOUS INJURY OR DEATH WILL RESULT IF THE INSTRUCTIONS ARE NOT FOLLOWED PROPERLY.

WARNING

THIS SIGNAL WORD IS USED WHERE SERIOUS INJURY OR DEATH COULD RESULT IF THE INSTRUCTIONS ARE NOT FOLLOWED PROPERLY.

CAUTION

THIS SIGNAL WORD IS USED WHERE MINOR INJURY COULD RESULT IF THE INSTRUCTIONS ARE NOT FOLLOWED PROPERLY.

NOTICE

NOTICE INDICATES A PROPERTY DAMAGE MESSAGE.

GENERAL SAFETY PRECAUTIONS

WARNING!

READ MANUAL PRIOR TO INSTALLATION



Improper installation, operation, or maintenance of this equipment could result in serious injury or death. Operators and maintenance personnel should read this manual, as well as all manuals related to this equipment and the prime mover thoroughly before beginning installation, operation, or maintenance. **FOLLOW ALL SAFETY INSTRUCTIONS IN THIS MANUAL AND THE PRIME MOVER'S MANUAL(S).**



READ AND UNDERSTAND ALL SAFETY STATEMENTS

Read all safety decals and safety statements in all manuals prior to operating or working on this equipment. Know and obey all OSHA regulations, local laws, and other professional guidelines for your operation. Know and follow good work practices when assembling, maintaining, repairing, mounting, removing, or operating this equipment.



KNOW YOUR EQUIPMENT

Know your equipment's capabilities, dimensions, and operations before operating. Visually inspect your equipment before you start, and never operate equipment that is not in proper working order with all safety devices intact. Check all hardware to ensure it is tight. Make certain that all locking pins, latches, and connection devices are properly installed and secured. Remove and replace any damaged, fatigued, or excessively worn parts. Make certain all safety decals are in place and are legible. Keep decals clean, and replace them if they become worn or hard to read.

GENERAL SAFETY PRECAUTIONS

WARNING!



PROTECT AGAINST FLYING DEBRIS

Always wear proper safety glasses, goggles, or a face shield when driving pins in or out, or when any operation causes dust, flying debris, or any other hazardous material.

WARNING!



LOWER OR SUPPORT RAISED EQUIPMENT

Do not work under raised booms without supporting them. Do not use support material made of concrete blocks, logs, buckets, barrels, or any other material that could suddenly collapse or shift positions. Make sure support material is solid, not decayed, warped, twisted, or tapered. Lower booms to ground level or on blocks. Lower booms and attachments to the ground before leaving the cab or operator's station.

WARNING!



USE CARE WITH HYDRAULIC FLUID PRESSURE

Hydraulic fluid under pressure can penetrate the skin and cause serious injury or death. Hydraulic leaks under pressure may not be visible. Before connecting or disconnecting hydraulic hoses, read your prime mover's operator's manual for detailed instructions on connecting and disconnecting hydraulic hoses or fittings.

- Keep unprotected body parts, such as face, eyes, and arms as far away as possible from a suspected leak. Flesh injected with hydraulic fluid may develop gangrene or other permanent disabilities.
- If injured by injected fluid, see a doctor at once. If your doctor is not familiar with this type of injury, ask him or her to research it immediately to determine proper treatment.
- Wear safety glasses, protective clothing, and use a piece of cardboard or wood when searching for hydraulic leaks. **DO NOT USE YOUR HANDS! SEE ILLUSTRATION.**

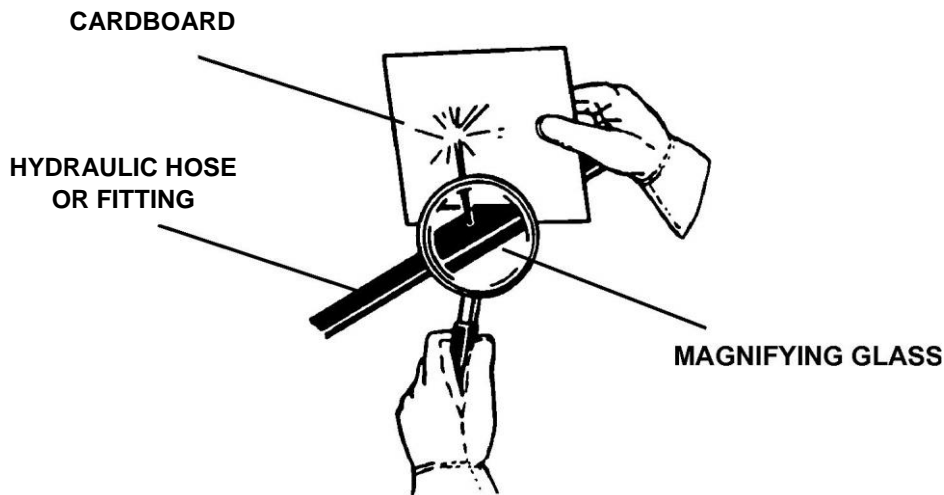

GENERAL SAFETY PRECAUTIONS

WARNING!



DO NOT MODIFY MACHINE OR ATTACHMENTS

Modifications may weaken the integrity of the attachment and may impair the function, safety, life, and performance of the attachment. When making repairs, use only the manufacturer's genuine parts, following authorized instructions. Other parts may be substandard in fit and quality. Never modify any ROPS (Roll Over Protection Structure) or FOPS (Falling Object Protective Structure) equipment or device. Any modifications must be authorized in writing by the manufacturer.

WARNING!



SAFELY MAINTAIN AND REPAIR EQUIPMENT

- Do not wear loose clothing or any accessories that can catch in moving parts. If you have long hair, cover or secure it so that it does not become entangled in the equipment.
- Work on a level surface in a well-lit area.
- Use properly grounded electrical outlets and tools.
- Use the correct tools for the job at hand. Make sure they are in good condition for the task required.
- Wear the protective equipment specified by the tool manufacturer.



SAFELY OPERATE EQUIPMENT

Do not operate equipment until you are completely trained by a qualified operator in how to use the controls, know its capabilities, dimensions, and all safety requirements. See your machine's manual for these instructions.

- Keep all step plates, grab bars, pedals, and controls free of dirt, grease, debris, and oil.
- Never allow anyone to be around the equipment when it is operating.
- Do not allow riders on the attachment or the prime mover.
- Do not operate the equipment from anywhere other than the correct operator's position.
- Never leave equipment unattended with the engine running, or with this attachment in a raised position.
- Do not alter or remove any safety feature from the prime mover or this attachment.
- Know your work site safety rules as well as traffic rules and flow. When in doubt on any safety issue, contact your supervisor or safety coordinator for an explanation.

EQUIPMENT SAFETY PRECAUTIONS

WARNING!



KNOW WHERE UTILITIES ARE

Observe overhead electrical and other utility lines. Be sure equipment will clear them. When digging, call your local utilities for location of buried utility lines, gas, water, and sewer, as well as any other hazard you may encounter.

WARNING!



EXPOSURE TO RESPIRABLE CRYSTALLINE SILICA DUST ALONG WITH OTHER HAZARDOUS DUSTS MAY CAUSE SERIOUS OR FATAL RESPIRATORY DISEASE.

It is recommended to use dust suppression, dust collection and if necessary personal protective equipment during the operation of any attachment that may cause high levels of dust.

WARNING!



REMOVE PAINT BEFORE WELDING OR HEATING

Hazardous fumes/dust can be generated when paint is heated by welding, soldering or using a torch. Do all work outside or in a well ventilated area and dispose of paint and solvent properly. Remove paint before welding or heating.

When sanding or grinding paint, avoid breathing the dust. Wear an approved respirator. If you use solvent or paint stripper, remove stripper with soap and water before welding. Remove solvent or paint stripper containers and other flammable material from area. Allow fumes to disperse at least 15 minutes before welding or heating.

WARNING!



END OF LIFE DISPOSAL

At the completion of the useful life of the unit, drain all fluids and dismantle by separating the different materials (rubber, steel, plastic, etc.). Follow all federal, state and local regulations for recycling and disposal of the fluid and components.

OPERATING THE AUGER



- All bystanders should be kept a minimum of 10 feet (3 meters) away from the working area of the earth auger.

Operate only from the operator's station.

Avoid steep hillside operation which could cause the prime mover to overturn. Consult your prime mover operator's and safety manuals for maximum incline allowable. Reduce speed when driving over rough terrain, on a slope, or turning, to avoid overturning the vehicle.

An operator must not use drugs or alcohol, which can change his or her alertness or coordination. An operator taking prescription or over-the-counter drugs should seek medical advice on whether or not he or she can safely operate equipment.

Before exiting the prime mover, lower the attachment to the ground, apply the parking brakes, turn off the prime mover's engine, and remove the key.

- Flow and pressure gauges, fittings, and hoses must have a continuous operating pressure rating of at least 25 higher than highest pressures of the system.

EQUIPMENT SAFETY PRECAUTIONS



TRANSPORTING THE AUGER

Travel only with the earth auger in a safe transport position to prevent uncontrolled movement. Drive slowly over rough ground and on slopes.

Tether the earth auger with a chain, if necessary, to prevent uncontrolled swinging of the auger when moving from hole to hole.

Do not drive close to ditches, excavations, etc., cave in could result.

Do not smoke when refueling the prime mover. Allow room in the fuel tank for expansion.

Wipe up any spilled fuel. Secure cap tightly when done.

Remove the earth auger from the prime mover before transporting to and from the job site.



MAINTAINING THE AUGER

Before performing maintenance, lower the attachment to the ground, apply the parking brakes, turn off the engine, and remove the key.

Never adjust a relief valve for pressure higher than recommended by the prime mover manufacturer.

Never perform any work on an attachment unless you are authorized and qualified to do so. Always read the operator service manual's before any repair is made. After completing maintenance or repair, check for correct functioning of the attachment. If not functioning properly, always tag "DO NOT OPERATE" until all problems are corrected.

Worn, damaged, or illegible safety decals must be replaced. New safety decals can be ordered from Spartan® free of charge.

Never make hydraulic repairs while the system is under pressure. Serious personal injury or death could occur.

AUGER ASSEMBLY

3K2 ELECTRIC SELECT AUGER DRIVES

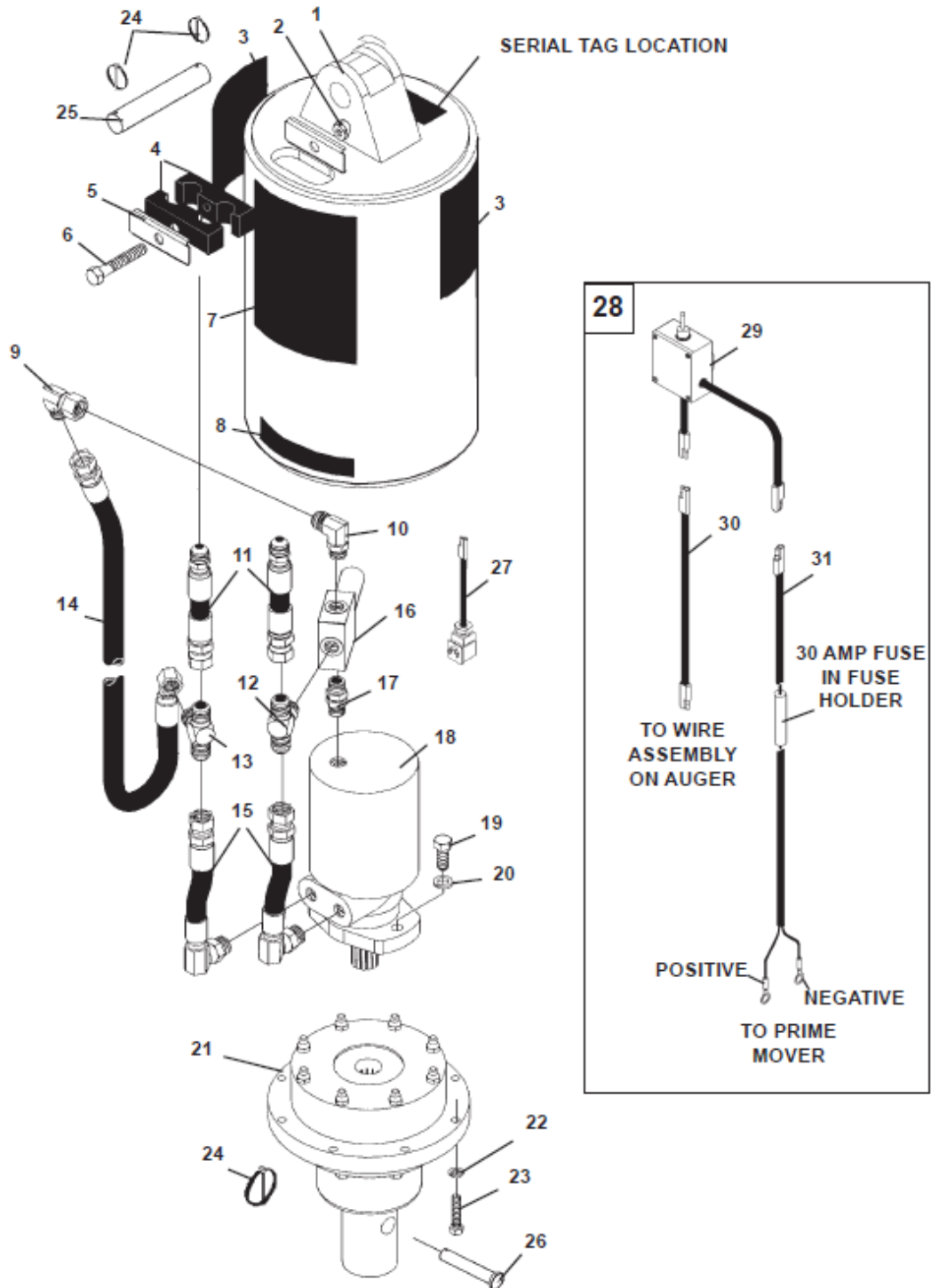

AUGER ASSEMBLY

3K2 ELECTRIC SELECT AUGER DRIVES

<u>ITEM</u>	<u>QTY</u>	<u>PART #</u>	<u>DESCRIPTION</u>
1	1	24522	Planetary Housing
2	1	1542	.50" UNC Nylock Nut
3	2	22680	Decal, Danger
4	1	24551	Hose Clamp Cushion
5	1	22315	Hose Clamp Plate
6	1	1096	.50" UNC X 3.00" Hex Capscrew
7	1	40745	Decal, Model
8	1	40557	Decal, Patent Pending
9	1	3447	90° Elbow 10MJ-10FJX
10	1	3313	90° Elbow 8MBo-10MJ
11	2	38201	Hose .50" X 7.00" 10MJ-10FJX
12	1	30340	Tee 10MJ-10MJ-8MBoX
13	1	30053	Tee 10MJ-10MJ-10MJ
14	1	38202	Hose .50" X 24" 10FJX-10FJX 90°
15	2	38200	Hose .50" X 7.88" 10FJX-10MBoX 90°
16	1	24479	Directional Solenoid Valve
17	1	30289	Straight Connector 8MBo-8MBo
18	1	100756	Hydraulic Motor
	1	22532	Motor Gasket
19	2	22336	.50" UNC X 1.50" SocketHead Capscrew Grade 8
20	2	1505	.50" Lock Washer
21	1	23526	Planetary Gearbox - 2" Hex
	1	23527	Planetary Gearbox - 2.56" Round
22	8	1503	.38" Lock Washer
23	8	1046	.38" UNC X 1.75" Hex Capscrew
24	3	21169	Klik Pin
25	1	22256	Pivot Pin
26	1	22263	Clevis Pin
27	1	101066	Wire Assembly (Switch to Valve)
28	1	15757	Control Box Assembly Option (Includes Items 29 through 31)
29	1	17710	Control Box Assembly
30	1	17712	Wire Assembly (Switch to Valve)
31	1	17173	Wire Assembly (Switch to Battery)

AUGER ASSEMBLY

3K2 MANUAL SELECT AUGER DRIVES

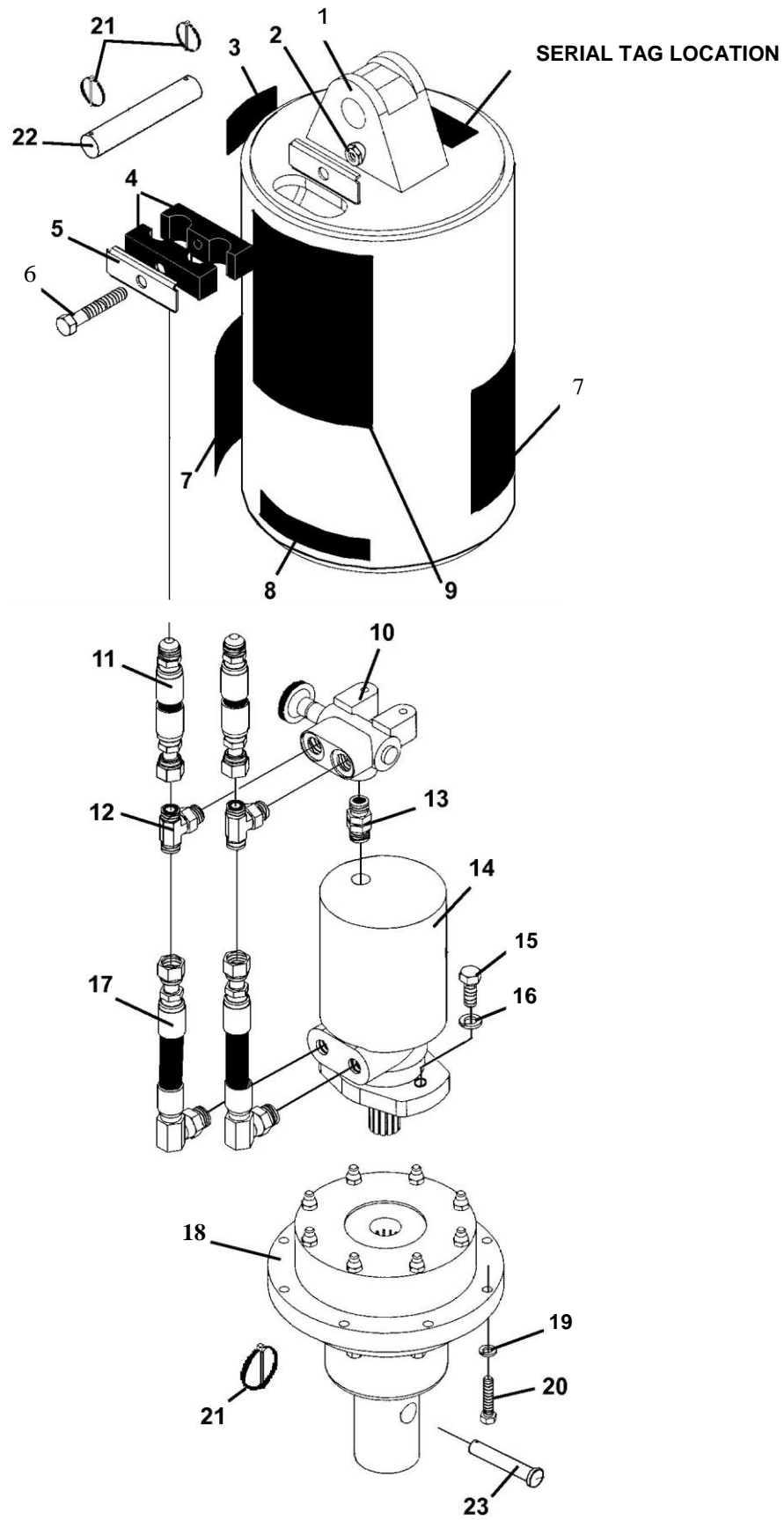

AUGER ASSEMBLY

3K2 MANUAL SELECT AUGER DRIVES

<u>ITEM</u>	<u>QTY</u>	<u>PART #</u>	<u>DESCRIPTION</u>
1	1	24480	Planetary Housing
2	1	1542	.50" UNC Nylock Nut
3	1	40747	Decal, Selector Valve
4	1	22317	Hose Clamp Cushion
5	1	22315	Hose Clamp Plate
6	1	1096	.50" UNC X 3.00" Hex Capscrew
7	2	22680	Decal, Danger
8	1	40557	Decal, Patent Pending
9	1	40745	Decal, Model
10	1	15088	Selector Valve
11	2	38191	Hose .50" X 6.50" 8FFS-10MJ
12	2	30343	Tee 8MFS-8MFS-8MBo
13	1	30289	Straight Connector 8MBo-8MBo
14	1	100756	Hydraulic Motor
	1	22532	Motor Gasket
15	2	22336	.50" UNC X 1.50" SocketHead Capscrew Grade 8
16	2	1505	.50" Lock Washer
17	2	38190	Hose .50" X 8.00" 8FFS-10MBo 90°
18	1	23526	Planetary Gearbox - 2" Hex
	1	23527	Planetary Gearbox - 2.56" Round
19	8	1503	.38" Lock Washer
20	8	1046	.38" UNC X 1.75" Hex Capscrew
21	3	21169	Klik Pin
22	1	22256	Pivot Pin
23	1	22263	Clevis Pin

QUICK ATTACH MOUNTING ASSEMBLIES

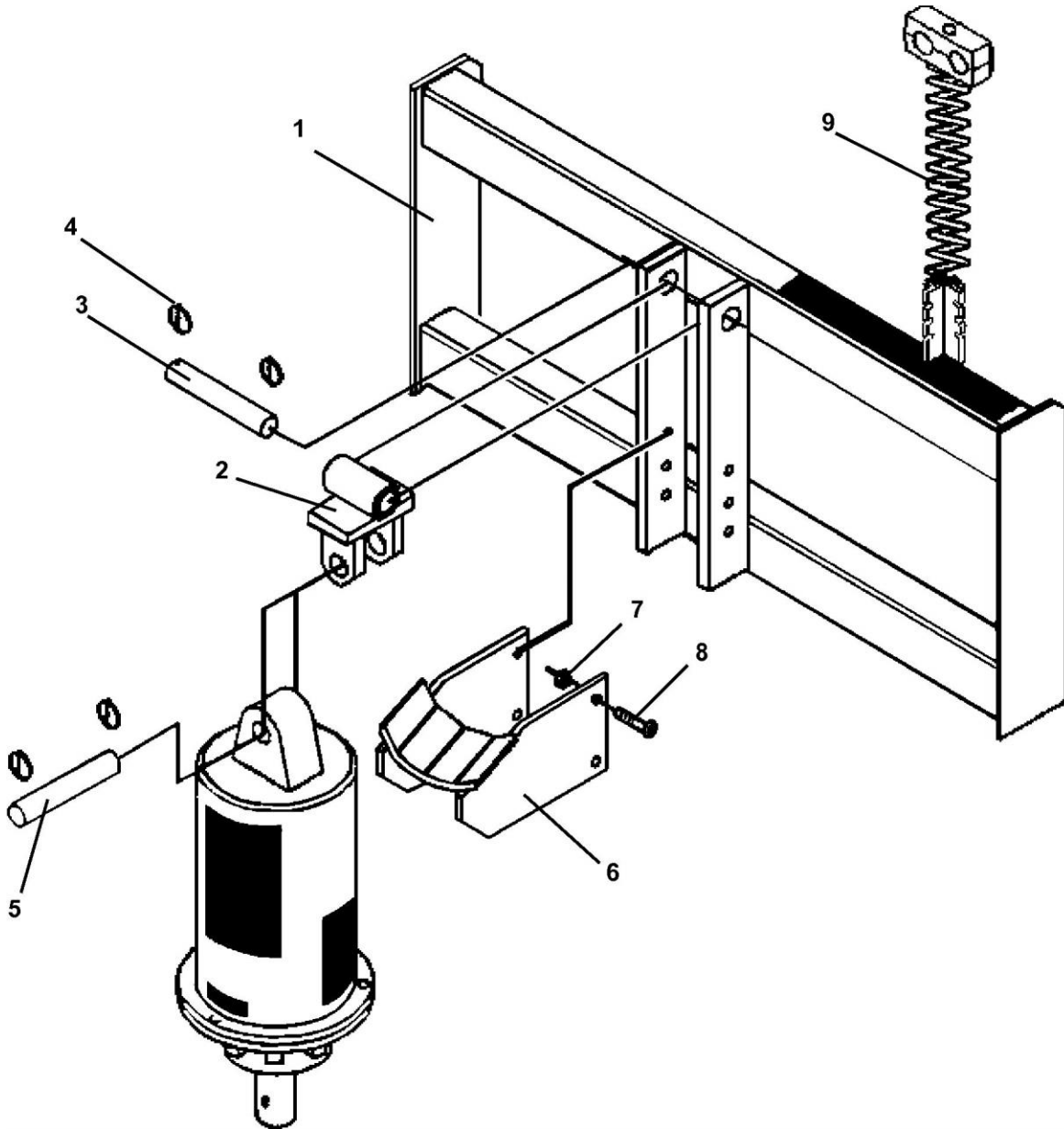

M-810 5-2-05

QUICK ATTACH MOUNTING ASSEMBLIES

<u>ITEM</u>	<u>QTY</u>	<u>PART #</u>	<u>DESCRIPTION</u>
1	1	Varies	Quick Attach Mounting Bracket
2	1	21694	Swivel Weldment
3	1	22255	Pin, 1.25" Dia. x 7.25" Long
4	4	21169	Lynch Pins
5	1	22256	Pin (Included With Drive Unit)
6	1	21670	Mounting Cradle
7	4	1228	.50" - 13 Hex Nut
8	4	1092	.50" - 13 x 2" Gr. 5 Bolt
9	1	21690	Spring Assembly (.50" Hose)
9	1	21693	Spring Assembly (.75" Hose)

BACKHOE & EXCAVATOR MOUNTING ASSEMBLIES

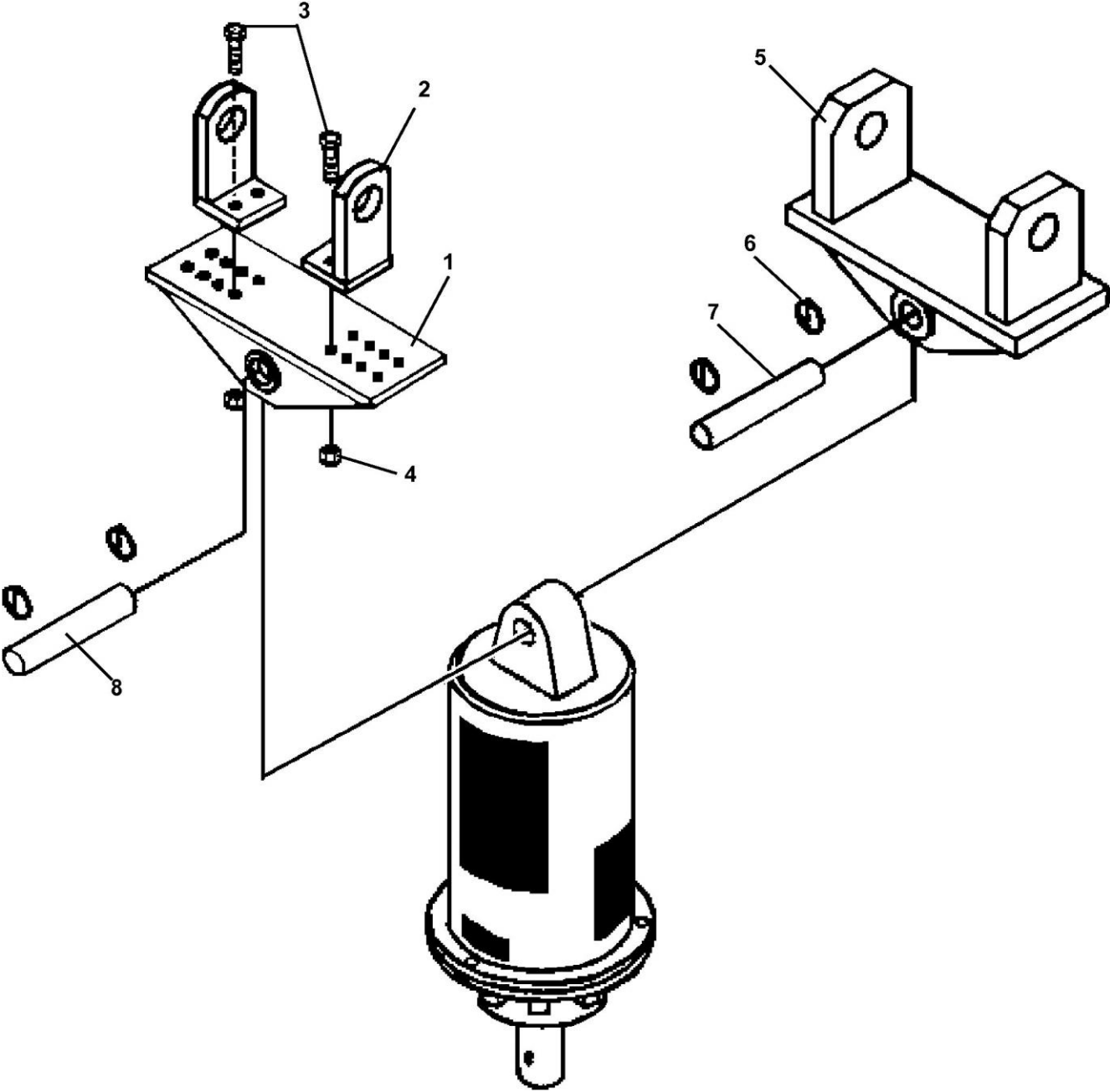

BACKHOE & EXCAVATOR MOUNTING ASSEMBLIES

<u>ITEM</u>	<u>QTY</u>	<u>PART #</u>	<u>DESCRIPTION</u>
1	1	21626	Backhoe Base Weldment
2	2	Varies	Backhoe Adaptor Ear
3	4	1091	.50" - 13 x 1.75" Gr. 5 Bolt
4	4	1841	.50" - 13 Locknut
5	1	Varies	Fixed Backhoe Mount
6	2	21169	Lynch Pins
7	1	22255	.125" Pin x 7.25" Long
8	1	22256	Pin (Included With Drive Unit)

UNIVERSAL FRONT END LOADER MOUNTING ASSEMBLY

ASSEMBLY #21235

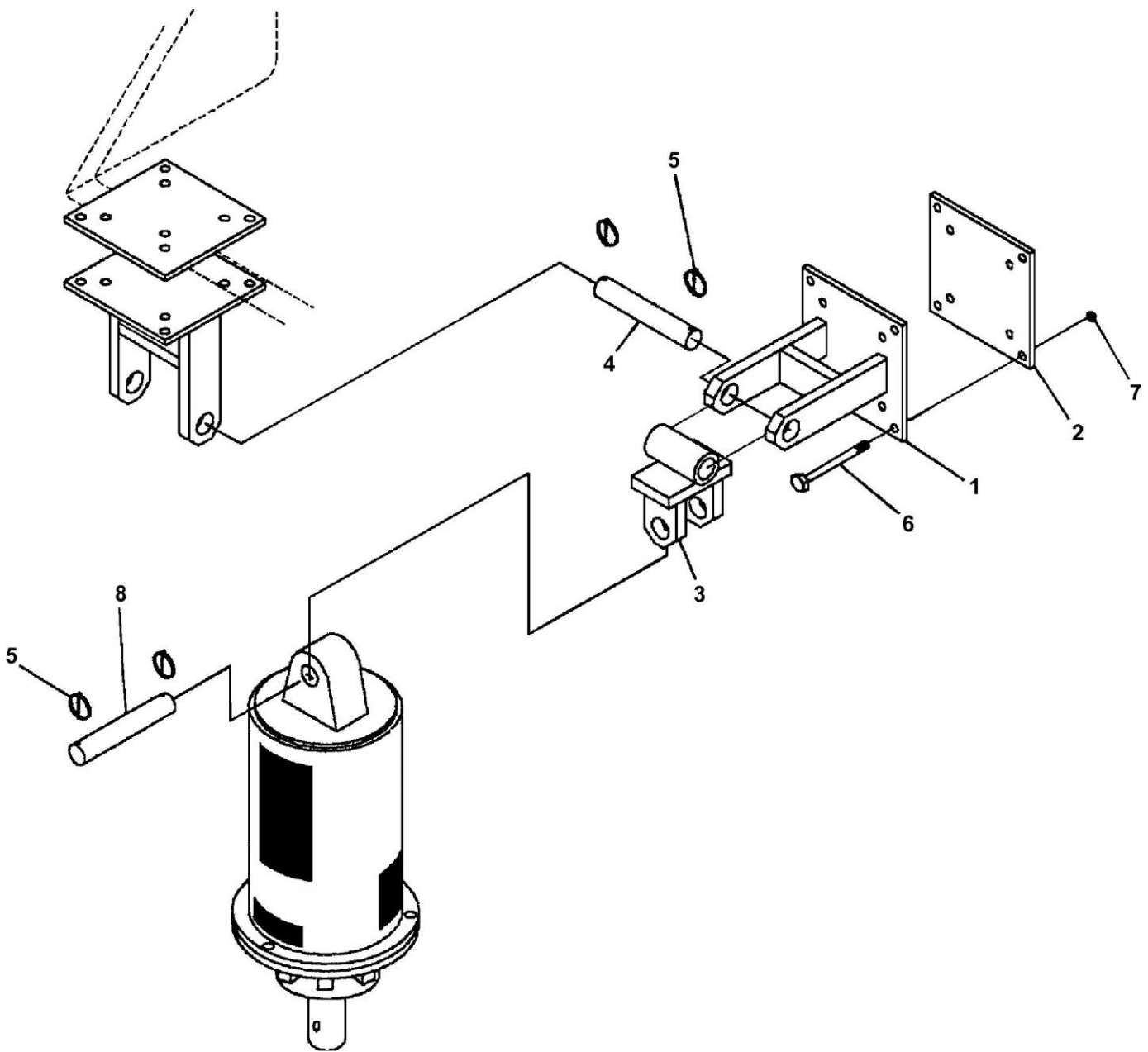

M-814 5-2-05

UNIVERSAL FRONT END LOADER MOUNTING ASSEMBLY

<u>ITEM</u>	<u>QTY</u>	<u>PART #</u>	<u>DESCRIPTION</u>
1	1	21628	Loader Bracket Weldment
2	1	21449	Loader Bracket Pad (Included With Item #1)
3	1	21694	Swivel Weldment
4	1	22255	Pin, 1.25" x 7.25" Long
5	4	21169	Lynch Pins
6	4	1080	.44 - 14 x 5.00", Gr. 5 Bolt
7	4	1227	.44 - 14 Hex Nut
8	1	22256	Pin (Included With Drive Unit)

MOUNTING & INSTALLATION INSTRUCTIONS

GENERAL INFORMATION

There are three types of mounting kits available for attaching your 3K2 2-speed earth drill: 1) Quick Attach Mounting Assemblies, 2) Backhoe & Excavator Mounting Assemblies, and

3) Universal Front End Loader Mounting Assembly. Find the mounting kit diagram and parts list for the kit you have received. Study the diagram and familiarize yourself with the names of the various parts. This knowledge will assist you in understanding these instructions.

Read these instructions carefully before attempting to mount the auger.

READ AND UNDERSTAND ALL SAFETY INFORMATION PRIOR TO MOUNTING YOUR AUGER.

QUICK ATTACH MOUNTING ASSEMBLIES

1. Remove the bucket or other attachment from the vehicle quick attach mechanism.
7. Attach the quick attach mounting bracket to vehicle quick attach mechanism, as per vehicle manufacturer's recommendations.
3. Attach the swivel weldment (21694) to the quick attach mounting bracket with pin (22255). Secure pin (22255) with lynch pins (21169).
4. Attach and secure drive unit to swivel weldment (21694) with pin (22256) and lynch pins (21169) provided with the drive unit assembly.
5. Attach and secure auger to drive unit with bolt and nut provided with drive unit assembly.
6. Refer to the "HYDRAULIC SYSTEM HOOK-UP" section in this manual for hydraulic connection instructions and recommendations.

BACKHOE & EXCAVATOR MOUNTING ASSEMBLIES

1. Remove bucket from dipper arm and curl cylinder pin connections. The dipper arm pin will be used to attach backhoe mounting to backhoe dipper arm. Curl cylinder pin will not be required for earth drill installation.
2. If using a Universal (adjustable width) Backhoe Mounting, assemble by spacing the two adaptor ears to the same width as the dipper arm, and secure to the backhoe swivel base (21626) with four bolts (1091). Secure bolts (1091) and nuts (1841). **After determining correct width, backhoe adaptor ears must be welded to backhoe swivel base (21626).**
3. Attach backhoe mounting (universal or fixed) to the dipper arm using the dipper arm pin removed from bucket in Step 1. Secure the bucket pin, as per vehicle manufacturer's recommendation.

MOUNTING & INSTALLATION INSTRUCTIONS - CONTINUED

4. Attach and secure drive unit to backhoe mounting with pin (21169) and pins (22256) provided with the drive unit assembly.
5. Attach and secure auger to drive unit, using bolt and nut provided with drive unit assembly.
6. Refer to the 'HYDRAULIC SYSTEM HOOK-UP' section in this manual for hydraulic connection instructions and recommendations.

UNIVERSAL FRONT END LOADER MOUNTING ASSEMBLY

1. The Universal Front End Loader Mounting Assembly (#21235) can be used to adapt your Spartan Hydraulic Earth Drill to the side of the loader arms, lip of bucket, or fork lift forks.
DO NOT USE ON SKID STEER LOADERS.
2. Place loader bracket pad (21449) on the inside of the loader arm, top of bucket lip (for mounting on lip of bucket you'll need to drill two 7/16" diameter holes through bucket), or top of fork lift fork. Opposite side of loader bracket pad (21449). Insert four bolts (1080), and secure with four nuts (1227).
3. Attach swivel weldment (21694) to the loader bracket weldment (21628) with pin (22255). Secure pin (22255) with lynch pins (21169).
4. Attach and secure drive unit to swivel weldment (21694) with pin and pin clips provided with the drive unit assembly.
5. Attach and secure auger to drive unit with bolt and nut provided with drive unit assembly.
6. Refer to the 'HYDRAULIC SYSTEM HOOK-UP' section in this manual for hydraulic connection instructions and recommendations.

HYDRAULIC SYSTEM HOOK-UP INSTRUCTIONS

1. Once the installation instructions are complete, you are now ready to make the hydraulic connections necessary to operate your earth drill. **READ AND UNDERSTAND SAFETY INFORMATION PRIOR TO MAKING HYDRAULIC CONNECTIONS.**
2. Your equipment dealer is in the best position to advise you as to where the best place on your machine is to make the hydraulic connections to power your earth drill drive unit. The list below shows the most common places to "tap" into the hydraulic system on various types of machines.

- **SKID STEER LOADERS** - Auxiliary hydraulic outlets.
- **BACKHOES & EXCAVATORS** - Auxiliary hydraulic outlets or bucket curl cylinder circuit.
- **WHEEL LOADERS & TRACTOR LOADERS** -Auxiliary hydraulic outlets or bucket tilt (dump) cylinder circuit.
- **TRACTOR 3-POINT HITCHES** - Remote (auxiliary hydraulic outlets).
- **FORKLIFTS** - Auxiliary hydraulic outlets or side-shift circuit.

3. Determine the length of hydraulic hoses required to plumb drive unit into the place on your machine where you'll be "tapping" into the hydraulics. Be sure the two hydraulic hoses are long enough to perform at the full range of the earth drill's operating capacity.

- **Model 3K2** - This model requires two 1/2" (12.7mm) or 3/4" (19mm) ID hydraulic hoses, with #10 JIC Female fittings on one end of each hose, to connect hoses to drive unit fittings.

NOTE: Fittings on the other end of each hydraulic hose should match the threads on the hydraulic quick couplers to be used.

WARNING! HOSES AND FITTINGS MUST HAVE A CONTINUOUS OPERATING PRESSURE RATING OF AT LEAST 25 HIGHER THAN THE HIGHEST PRESSURES OF THE SYSTEM YOU ARE "TAPPING" INTO.

4. Once all of the hydraulic connections have been made and checked for leaks, you are now ready to operate your earth drill. **READ AND UNDERSTAND OPERATING INSTRUCTIONS AND SAFETY INFORMATION PRIOR TO OPERATING YOUR EARTH DRILL.**

OPERATING INSTRUCTIONS

GENERAL INFORMATION

The 3K2 2-speed earth drill is available in two different configurations. One has a selector valve for manually selecting either High Speed-Low Torque or Low Speed-High Torque, and the other has a solenoid valve with an electric control box to select operating speed. The general digging is the same as above except the operator has the option of selecting between the two different speeds. Generally in light sandy soil or with the smaller diameter augers High Speed-Low Torque is the best operating speed, whereas in hard ground conditions or digging with large diameter augers we recommend the Low Speed-High Torque setting.

1. After all installation instructions have been completed, safety information read and understood, and the rest of this operator's manual has been reviewed, your Spartan Hydraulic Earth Drill is now ready for use.
2. Before beginning to dig, experiment with auger speed to determine which setting is best for your ground condition and auger diameter.
3. With the auger raised off the ground and the vehicle engine set at a low RPM, activate the earth drill control valve to determine position control valve lever must be in to turn auger in a forward (clockwise) rotation. This is the "digging" position.
4. Return earth drill control valve to neutral position to stop the auger. Lower the auger to the ground so that only the center point penetrates the ground about 2" (51 mm).
5. Activate the earth drill control valve so auger is turning in a forward (clockwise) rotation. Use only enough down pressure to assure positive penetration of auger into the ground. Ease up on down pressure if auger rotation slows down drastically or stalls. Excessive down pressure will cause the auger to stall frequently.
6. When auger has penetrated the ground about 24" (610 mm), raise the auger from the hole to clean the dirt out. Repeat this procedure until the desired hole depth is obtained.
7. Once the required hole depth is reached, allow the auger to turn a few seconds at this depth to clean the hole.
8. Return the earth drill control valve to the neutral position to stop the rotation of the auger. Raise the auger out of the hole, move away from the hole, then activate the earth drill control valve to spin the loose soil off of the augers.

NOTE: Do not reverse the auger rotation to remove from the hole, as loose soil on the auger flights will fall back into the hole.

9. If necessary, repeat steps 7 & 8 to obtain a cleaner hole.
10. In some soil conditions or when excessive down pressure is applied, auger may "screw" itself into the ground and become stuck, causing the earth drill to stall. If this happens, reverse the auger rotation (counter-clockwise) by moving the control valve lever to the reverse position, and slowly raise the auger. Once unstuck, return the control valve lever to the forward rotation position, and continue digging.
11. If the auger becomes lodged under rocks, roots, or other large obstructions, do not attempt to raise the auger out of the ground. See step 10 for the proper procedure to relieve the auger.
12. Avoid excessive side loading to earth drill, which can cause drive unit or auger damage.
13. Keep auger teeth and points in good condition. Check frequently, and always keep spares on hand so they can be replaced as wear is detected, to avoid damage to tooth holders and auger flighting.

MAINTENANCE INSTRUCTIONS

1. CLEAN HYDRAULIC OIL IS ESSENTIAL! 80 of all hydraulic component failures are caused by contamination of the hydraulic oil. Always keep all dirt and other contaminants from entering the hydraulic system during disconnect and connect operations. Always use dust caps and plugs on all quick disconnects when not in use. Tightly cap all hydraulic openings to hold oil in and keep dirt and other contaminants from entering hydraulic systems.
2. CHECK HYDRAULIC OIL DAILY FOR CONTAMINATION. If contamination is present, determine the source of the problem.
3. INSPECT ALL HYDRAULIC HOSE ASSEMBLIES DAILY for cracked and brittle covers caused by excessive heat. Reduced viscosity of hydraulic oil occurs at higher operating temperatures and causes a breakdown of fluid additives, such as wear inhibitors. Excessive heat will cause higher internal leakage in the drive unit motor, which will make the drive unit less efficient. It can also cause seals in the drive unit motor to become brittle and crack. Replacement of hoses before failure will prevent loss of hydraulic oil, time consuming "bleeding" of the system, hydraulic oil contamination, and component damage caused by cavitation. It will also reduce the chance of personal injury caused by hydraulic fluid.
4. CHECK AUGER DAILY for loose, worn, or broken cutting teeth and point. Worn teeth or point can drastically affect auger penetration, and greatly reduce auger life expectancy. Always keep spare teeth and points on hand. Some digging conditions may require checking teeth and point at more frequent intervals.
5. CHECK DRIVE UNIT AND ALL ACCESSORIES DAILY for loose, bent, cracked, or worn bolts and fasteners. Always use Grade 5 or harder replacement bolts. Always use lock washers with standard hex nuts or self-locking nuts.
6. CHECK ALL CONNECTING PINS DAILY for bends, cracks, breaks, or wear. Replace if any of these conditions exist.
7. CHECK DRIVE UNIT OUTPUT SHAFT DAILY for bends, cracks, breaks, or wear. Replace if any of these conditions exist.
8. CHANGE PLANETARY GEAR REDUCTION OIL AFTER FIRST 50 HOURS OF OPERATION, THEN EVERY 1000 HOURS OR TWELVE MONTHS, WHICHEVER COMES FIRST. Use mild extreme pressure lubricant API-GL-5, no. 80 or 90 for filling the planetary gear reduction under normal temperature ranges between 0° -120° F (-18° - 49° C). The approximate oil capacity for model 3K2 is two pints (.95 liters). CHECK OIL LEVEL DAILY to assure proper lubrication is maintained.
9. WHEN STORING DRIVE UNIT for any length of time, be sure the drive unit motor and hoses are full of clean oil. Be sure the planetary gear reduction is full (to the recommended capacity for each model), as outlined in number 8 above.

MAINTENANCE INSTRUCTIONS

10. The Drive Unit output shaft, inside of auger collar, variable auger extension shaft, inside of variable auger extension collar, and all connecting pins should be coated liberally with grease, to prevent rust and reduce wear.
11. Once paint has been worn off the auger, coat liberally with grease, as required, to prevent rusting.
12. Check planetary gear oil as follows: Lay drive unit horizontal with the ground and with drain plug straight up. Verify that the output shaft is completely covered with oil. Add as needed.

MAINTENANCE INSTRUCTIONS

PLANETARY GEAR REDUCTION FOR 3K2

Exploded View and Parts List

*** WARRANTY NOTICE:** Any attempt to disassemble or make field repairs to the planetary will void warranty. Contact your Dealer/Distributor.

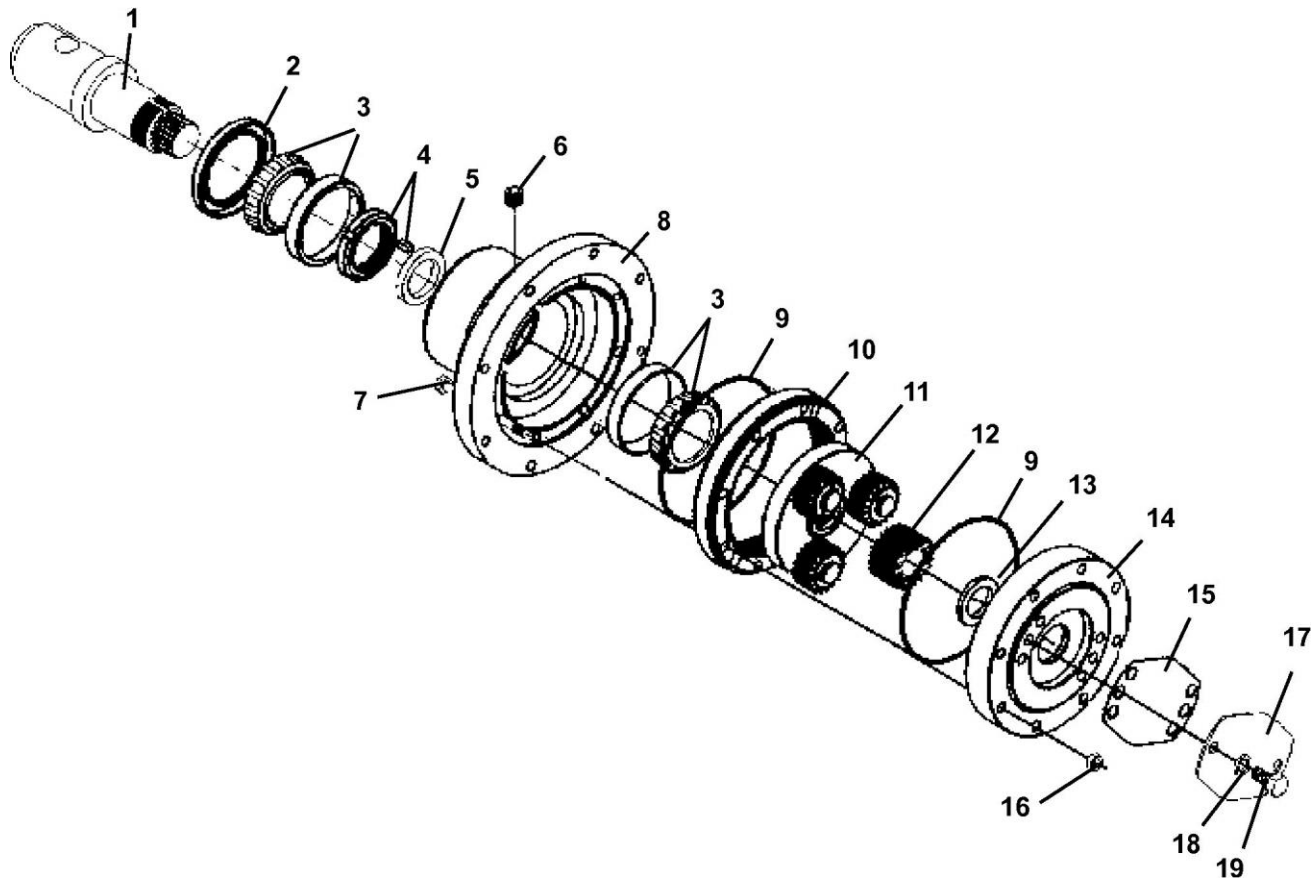

ITEM #	QTY	PART #	DESCRIPTION
1	1	15071	2-9-16" Round Shaft
1	1	15072	2" Hex
2	1	33510	Seal
3	2	31681	Bearing/Cone
4	1	101526	Lock Nut with Tab Washer (Replaces Nut with Key)
5	1	15073	Spacer
6	1	15074	Plug
7	8	31671	Bolt
8	1	15075	Housing
9	2	31674	O-Ring
10	1	31675	Ring Gear
11	1	15335	Gear Set
12	1	15336	Sun Gear
13	1	31673	Thrust Washer
14	1	31672	Cover
15	1	31670	Gasket
16	8	31685	Nut
17	1	15076	Plate
18	2	15077	Washer
19	2	31664	Bolt

M-827 4-26-05

TROUBLESHOOTING

PROBLEM	POSSIBLE CAUSE	POSSIBLE SOLUTION
Slow Speed	Low Flow	Check with flow meter. If low investigate cause.
	Line restrictions	Clear lines.
	Fittings or connections too small	Replace with proper sizes.
	Oil filter dirty	Replace.
	Hydraulic pump worn or damaged	See Dealer for repair.
Insufficient Digging Power	Worn teeth or point	Replace.
	Low system Pressure (PSI)	Check with pressure gauge. If low, investigate cause.
	Relief Valve damaged or setting wrong	Adjust or replace as required.
	Excessive load	Reduce load to within machine specifications.
Won't Shift Between High & Low Gear	Solenoid valve damaged.	Check and replace, as required.
	Selector valve damaged.	Check and replace, as required.
Reverse Direction	Hoses reversed	Re-install hoses correctly.
Excessive Oil Heating	Line restrictions	Clear lines.
	Fluid dirty	Replace hydraulic fluid and filter.
	Insufficient quantity of hydraulic fluid	Fill reservoir to proper level. Increase reservoir storage capacity.
Oil Leaks	Hoses loose or damaged	Tighten or replace.
	Fittings loose or damaged	Tighten or replace.
	Hydraulic motor seals worn or damaged	See Dealer for repair.

DRIVE UNIT SPECIFICATIONS

MODEL 3K2

Maximum Auger Diameter: 36" (914 mm)
 Minimum Hydraulic Flow: 10 gpm (38 lpm)
 Maximum Hydraulic Flow: 25 gpm (95 lpm)
 Maximum Continuous Operating PSI: 3000 psi (207 bar)
 Output Shaft Options: 2-9/16" (65mm) Round
 2" (51mm) Hex

FLOW	OUTPUT SPEED		OUTPUT TORQUE		
	LOW SPEED	HIGH SPEED	PRESSURE	HIGH TORQUE	LOW TORQUE
GPM (LPM) =	RPM	RPM	PSI (BAR) =	Lb·Ft(N·m)	Lb·Ft(N·m)
15 (57) =	37	59	3000(207) =	2053(2783)	2923(3963)
20 (76) =	48	81			

HDC STYLE AUGER WEAR PARTS LIST

AUGER DIA.	6"	8"	9"	10"	12"	15"	16"	18"	20"	24"	30"	36"	42"	48"
Part #	152mm	203mm	229mm	254mm	305mm	381mm	406mm	467mm	508mm	610mm	762mm	914mm	1067mm	1219mm
Description (Standard Components)	Hardened Drive-In Gage Tooth	Hardened Drive-In Gage Tooth	Hardened Drive-In Wisdom Tooth	3.50" Hardened Fishtail Point (male shaft)	Rubber Lock									
Qty	2	2	2	2	2	2	2	2	2	2	2	2	2	2
Qty	1	1	1	1	1	1	1	1	1	1	1	1	1	1
Qty	2	4	4	4	4	6	6	6	6	8	10	12	16	20

HDF STYLE AUGER WEAR PARTS LIST

AUGER DIA.	4"	6"	8"	9"	10"	12"	15"	16"	18"	20"	24"	30"	36"
Part #	102mm	152mm	203mm	229mm	254mm	305mm	381mm	406mm	457mm	508mm	610mm	762mm	914mm
Description (Standard Components)	Hardened Bolt-on Gage Tooth	Hardened Bolt-on Wisdom Tooth	3.50" Hardened Fishtail Point (male shaft)	4.50" Hardened Fishtail Point	Carrriage Bolt	Nut							
Qty	-	-	1	1	1	1	1	1	1	1	1	1	1
Qty	2	2	2	2	2	2	2	2	2	2	2	2	2
Qty	3	6	7	1	1	1	1	1	1	1	1	1	1
Qty	7	10	11	13	15	17	17	17	17	17	17	17	17

HTF STYLE AUGER WEAR PARTS LIST

AUGER DIA.	18"	24"	30"	36"	42"	48"
Part #	457mm	610mm	762mm	914mm	1067mm	1219mm
Description (Standard Components)	Hardened Bolt-on Gage Tooth	Hardened Bolt-on Wisdom Tooth	3.50" Hardened Fishtail Point (male shaft)	Carrriage Bolt	Nut	
Qty	4	4	4	4	4	4
Qty	3	6	7	9	11	13
Qty	1	1	1	1	1	1
Qty	7	10	11	13	15	17
Qty	7	10	11	13	15	17

OPTIONAL HARDFACED & CARBIDE WEAR COMPONENTS

Part #	Description
22170	Hardfaced Wisdom Tooth
22186	Carbide Wisdom Tooth
22181	Hardened Chisel Tooth
22183	Hardfaced Chisel Tooth
22182	Carbide Chisel Tooth
22190	3.50" Hardened Fishtail Point (Male Hub)
22192	3.50" Hardfaced Fishtail Point (Male Hub)
22191	3.50" Carbide Fishtail Point (Male Hub)
22193	3.50" Hardfaced /Carbide Fishtail Point (Male Hub)
22003	4.50" Hardened Fishtail Point (Female)
22004	4.50" Hardfaced Fishtail Point (Female)
22005	4.50" Hardfaced /Carbide Fishtail Point (Female)
22171	3.50" Hardened Fishtail Point (Female)
22172	3.50" Carbide Fishtail Point (Female)
22173	3.50" Hardfaced Fishtail Point (Female)
22174	3.50" Hardfaced /Carbide Fishtail Point (Female)

NOTE: Contact your equipment dealer for wear components not listed above. If you have any special auger needs or applications, feel free to contact McMillen.

IMPORTANT: McMillen does not recommend augers exceeding 36" diameter for C-Series Drive Units.

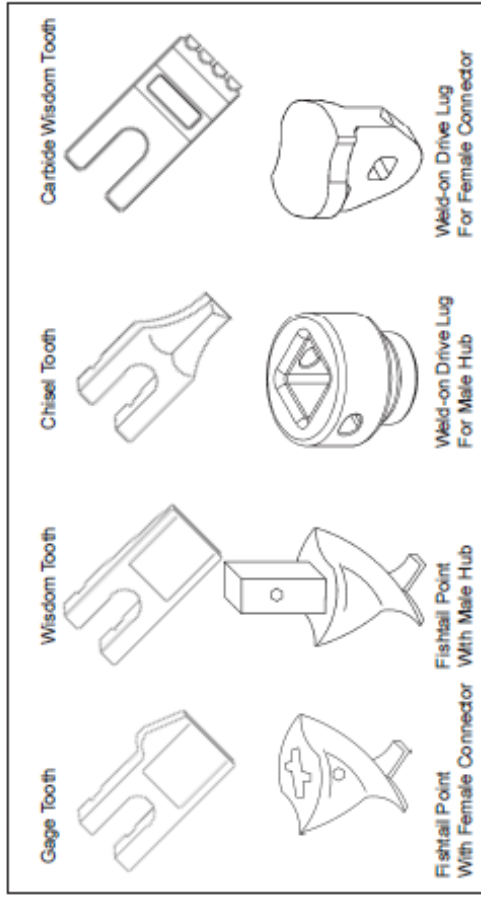

M-118 4-27-05-3

Limited Warranty - Spartan AUGERS

Except for the Excluded Products as described below, all new products are warranted to be free from defects in material and/or workmanship during the Warranty Period, in accordance with and subject to the terms and conditions of this Limited Warranty.

1. Excluded Products. The following products are excluded from this Limited Warranty:

(a) Any cable, part that engages with the ground (i.e. sprockets), digging chain, bearing, teeth, tamping and/or demolition head, blade cutting edge, pilot bit, auger teeth and broom brush that either constitutes or is part of a product.

(b) Any product, merchandise or component that, in the opinion of Spartan Equipment", has been (i) misused; (ii) modified in any unauthorized manner; (iii) altered; (iv) damaged; (v) involved in an accident; or (vi) repaired using parts not obtained through Spartan Equipment.

2. Warranty Period. The Limited Warranty is provided only to those defects that occur during the Warranty Period, which is the period that begins on the first to occur of: (i) the date of initial purchase by an end-user, (ii) the date the product is first leased or rented, or (iii) the date that is six (6) months after the date of shipment by Spartan Equipment as evidenced by the invoiced shipment date (the "Commencement Date") and ends on the date that is twenty-four (24) months after the Commencement Date. (NOTE: The Planetary Gearbox ONLY carries an additional 3 years warranty.)

3. Terms and Conditions of Limited Warranty. The following terms and conditions apply to the Limited Warranty hereby provided:

(a) Option to Repair or Replace. Spartan Equipment shall have the option to repair or replace the product.

(b) Timely Repair and Notice. In order to obtain the Limited Warranty, (i) the product must be repaired within thirty (30) days from the date of failure, and (ii) a claim under the warranty must be submitted to Spartan Equipment in writing within thirty (30) days from the date of repair.

(c) Return of Defective Part or Product. If requested by Spartan Equipment, the alleged defective part or product shall be shipped to Spartan Equipment at its manufacturing facility or other location specified by Spartan Equipment, with freight PRE-PAID by the claimant, to allow Spartan Equipment to inspect the part or product.

Claims that fail to comply with any of the above terms and conditions shall be denied.

LIMITATIONS AND EXCLUSIONS.

THIS LIMITED WARRANTY IS IN LIEU OF ALL OTHER WARRANTIES, EXPRESS OR IMPLIED, INCLUDING WITHOUT LIMITATION THE WARRANTIES OF MERCHANTABILITY, FITNESS FOR A PARTICULAR PURPOSE AND ANY WARRANTY BASED ON A COURSE OF DEALING OR USAGE OF TRADE.

IN NO EVENT SHALL SPARTAN EQUIPMENT BE LIABLE FOR CONSEQUENTIAL OR SPECIAL DAMAGES.

IN NO EVENT SHALL SPARTAN EQUIPMENT BE LIABLE FOR ANY LOSS OR CLAIM IN AN AMOUNT IN EXCESS OF THE PURCHASE PRICE, OR, AT THE OPTION OF SPARTAN EQUIPMENT, THE REPAIR OR REPLACEMENT, OF THE PARTICULAR PRODUCT ON WHICH ANY CLAIM OF LOSS OR DAMAGE IS BASED. THIS LIMITATION OF LIABILITY APPLIES IRRESPECTIVE OF WHETHER THE CLAIM IS BASED ON BREACH OF CONTRACT, BREACH OF WARRANTY, NEGLIGENCE OR OTHER CAUSE AND WHETHER THE ALLEGED DEFECT IS DISCOVERABLE OR LATENT.

February 10, 2010
M-804B 2-15-10-3