



SPARTAN EQUIPMENT

OPERATOR'S AND PARTS MANUAL

VIBRATORY ROLLER



SERIAL NUMBER: _____

MODEL NUMBER: _____

Manual Number: OM695

Part Number: 75595

Rev. 4

TABLE OF CONTENTS

PREFACE	3
SAFETY PRECAUTIONS	
SAFETY STATEMENTS	5
GENERAL SAFETY PRECAUTIONS	5-7
EQUIPMENT SAFETY PRECAUTIONS	8
DECALS	
DECAL PLACEMENT	9
DECALS	10-11
INSTALLATION	
GENERAL INFORMATION	12
NOMENCLATURE	12
ATTACHING	12
DETACHING	13
OPERATING INSTRUCTIONS	
GENERAL INFORMATION	14
OPERATING PROCEDURE	14
MAINTENANCE AND SERVICE	
GENERAL MAINTENANCE - EVERY 8 /100/500 HOURS	15-16
CHANGING GEAR LUBE	16
DRUM REMOVAL.	16
DRUM INSTALLATION	17
REPLACING VIBRATION ISOLATORS	17-18
REPLACING LEFT BEARINGS AND/OR HUBS	18-19
REPLACING RIGHT BEARINGS AND/OR HUBS	20-21
HYDRAULIC MOTOR REPLACEMENT.	21
TROUBLESHOOTING	22
SPECIFICATIONS	
BOLT TORQUE SPECIFICATIONS	23
VIBRATORY ROLLER SPECIFICATIONS	24
LIMITED WARRANTY	25
PARTS	
SMOOTH VIBRATORY ROLLER ASSEMBLIES	26-27
PADDED VIBRATORY ROLLER ASSEMBLIES	28-29
SPRING CLAMPASSEMBLY	30-31
FRAME ASSEMBLIES	32-33
SMOOTH DRUM ASSEMBLIES	34-35
PADDED DRUM ASSEMBLIES	36-37
HUB ASSEMBLIES	38-39
HYDRAULIC ASSEMBLY	40-41

**THIS PAGE
IS INTENTIONALLY
BLANK**

PREFACE

GENERAL COMMENTS

Congratulations on the purchase of your new SPARTAN EQUIPMENT product! This product was carefully designed and manufactured to give you many years of dependable service. Only minor maintenance (such as cleaning and lubricating) is required to keep it in top working condition. Be sure to observe all maintenance procedures and safety precautions in this manual and on any safety decals located on the product and on any equipment on which the attachment is mounted.

This manual has been designed to help you do a better, safer job. Read this manual carefully and become familiar with its contents.

WARNING!



Never let anyone operate this unit without reading the "Safety Precautions" and "Operating Instructions" sections of this manual.

Always choose hard, level ground to park the vehicle on and set the brake so the unit cannot roll.

Unless noted otherwise, right and left sides are determined from the operator's control position when facing the attachment.

NOTE: The illustrations and data used in this manual were current (according to the information available to us) at the time of printing, however, we reserve the right to redesign and change the attachment as may be necessary without notification.

BEFORE OPERATION

The primary responsibility for safety with this equipment falls to the operator. Make sure the equipment is operated only by trained individuals that have read and understand this manual. If there is any portion of this manual or function you do not understand, contact your local authorized dealer or the manufacturer to obtain further assistance. Keep this manual available for reference. Provide the manual to any new owners and/or operators.

SAFETY ALERT SYMBOL



This is the "Safety Alert Symbol" used by this industry. This symbol is used to warn of possible injury. Be sure to read all warnings carefully. They are included for your safety and for the safety of others working with you.

SERVICE

Use only manufacturer replacement parts. Substitute parts may not meet the required standards.

Record the model and serial number of your unit on the cover of this manual. The parts department needs this information to insure that you receive the correct parts.

SOUND AND VIBRATION

Sound pressure levels and vibration data for this attachment are influenced by many different parameters: some items are listed below (not inclusive):

- prime mover type, age, condition, with or without cab enclosure and configuration
- operator training, behavior, stress level
- job site organization, working material condition, environment

Based on the uncertainty of the prime mover, operator, and job site, it is not possible to get precise machine and operator sound pressure levels or vibration levels for this attachment.

**THIS PAGE
IS INTENTIONALLY
BLANK**

SAFETY STATEMENTS



THIS SYMBOL BY ITSELF OR WITH A WARNING WORD THROUGHOUT THIS MANUAL IS USED TO CALL YOUR ATTENTION TO INSTRUCTIONS INVOLVING YOUR PERSONAL SAFETY OR THE SAFETY OF OTHERS. FAILURE TO FOLLOW THESE INSTRUCTIONS CAN RESULT IN INJURY OR DEATH.



DANGER

THIS SIGNAL WORD IS USED WHERE SERIOUS INJURY OR DEATH WILL RESULT IF THE INSTRUCTIONS ARE NOT FOLLOWED PROPERLY.



WARNING

THIS SIGNAL WORD IS USED WHERE SERIOUS INJURY OR DEATH COULD RESULT IF THE INSTRUCTIONS ARE NOT FOLLOWED PROPERLY.



CAUTION

THIS SIGNAL WORD IS USED WHERE MINOR INJURY COULD RESULT IF THE INSTRUCTIONS ARE NOT FOLLOWED PROPERLY.



NOTICE

NOTICE INDICATES A PROPERTY DAMAGE MESSAGE.

GENERAL SAFETY PRECAUTIONS

WARNING!

READ MANUAL PRIOR TO INSTALLATION



Improper installation, operation, or maintenance of this equipment could result in serious injury or death. Operators and maintenance personnel should read this manual, as well as all manuals related to this equipment and the prime mover thoroughly before beginning installation, operation, or maintenance. **FOLLOW ALL SAFETY INSTRUCTIONS IN THIS MANUAL AND THE PRIME MOVER'S MANUAL(S).**

READ AND UNDERSTAND ALL SAFETY STATEMENTS



Read all safety decals and safety statements in all manuals prior to operating or working on this equipment. Know and obey all OSHA regulations, local laws, and other professional guidelines for your operation. Know and follow good work practices when assembling, maintaining, repairing, mounting, removing, or operating this equipment.

KNOW YOUR EQUIPMENT



Know your equipment's capabilities, dimensions, and operations before operating. Visually inspect your equipment before you start, and never operate equipment that is not in proper working order with all safety devices intact. Check all hardware to ensure it is tight. Make certain that all locking pins, latches, and connection devices are properly installed and secured. Remove and replace any damaged, fatigued, or excessively worn parts. Make certain all safety decals are in place and are legible. Keep decals clean, and replace them if they become worn or hard to read.

GENERAL SAFETY PRECAUTIONS

WARNING!



PROTECT AGAINST FLYING DEBRIS

Always wear proper safety glasses, goggles, or a face shield when driving pins in or out, or when any operation causes dust, flying debris, or any other hazardous material.

WARNING!



LOWER OR SUPPORT RAISED EQUIPMENT

Do not work under raised booms without supporting them. Do not use support material made of concrete blocks, logs, buckets, barrels, or any other material that could suddenly collapse or shift positions. Make sure support material is solid, not decayed, warped, twisted, or tapered. Lower booms to ground level or on blocks. Lower booms and attachments to the ground before leaving the cab or operator's station.

WARNING!



USE CARE WITH HYDRAULIC FLUID PRESSURE

Hydraulic fluid under pressure can penetrate the skin and cause serious injury or death. Hydraulic leaks under pressure may not be visible. Before connecting or disconnecting hydraulic hoses, read your prime mover's operator's manual for detailed instructions on connecting and disconnecting hydraulic hoses or fittings.

- Keep unprotected body parts, such as face, eyes, and arms as far away as possible from a suspected leak. Flesh injected with hydraulic fluid may develop gangrene or other permanent disabilities.
- If injured by injected fluid, see a doctor at once. If your doctor is not familiar with this type of injury, ask him to research it immediately to determine proper treatment.
- Wear safety glasses, protective clothing, and use a piece of cardboard or wood when searching for hydraulic leaks. **DO NOT USE YOUR HANDS!**
SEE ILLUSTRATION.

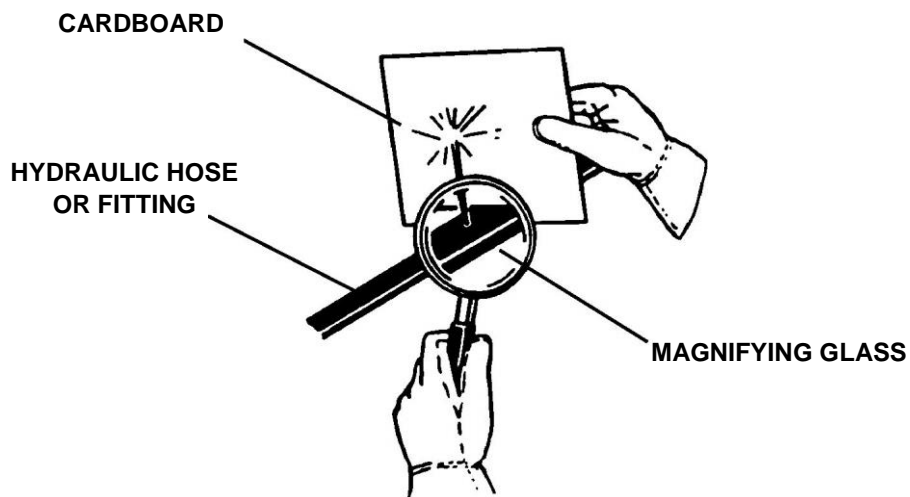

GENERAL SAFETY PRECAUTIONS

WARNING!



DO NOT MODIFY MACHINE OR ATTACHMENTS

Modifications may weaken the integrity of the attachment and may impair the function, safety, life, and performance of the attachment. When making repairs, use only the manufacturer's genuine parts, following authorized instructions. Other parts may be substandard in fit and quality. Never modify any ROPS (Roll Over Protection Structure) or FOPS (Falling Object Protective Structure) equipment or device. Any modifications must be authorized in writing by the manufacturer.

WARNING!



SAFELY MAINTAIN AND REPAIR EQUIPMENT

- Do not wear loose clothing or any accessories that can catch in moving parts. If you have long hair, cover or secure it so that it does not become entangled in the equipment.
- Work on a level surface in a well-lit area.
- Use properly grounded electrical outlets and tools.
- Use the correct tools for the job at hand. Make sure they are in good condition for the task required.
- Wear the protective equipment specified by the tool manufacturer.

SAFELY OPERATE EQUIPMENT



Do not operate equipment until you are completely trained by a qualified operator in how to use the controls, know its capabilities, dimensions, and all safety requirements. See your machine's manual for these instructions.

- Keep all step plates, grab bars, pedals, and controls free of dirt, grease, debris, and oil.
- Never allow anyone to be around the equipment when it is operating.
- Do not allow riders on the attachment or the prime mover.
- Do not operate the equipment from anywhere other than the correct operator's position.
- Never leave equipment unattended with the engine running, or with this attachment in a raised position.
- Do not alter or remove any safety feature from the prime mover or this attachment.
- Know your work site safety rules as well as traffic rules and flow. When in doubt on any safety issue, contact your supervisor or safety coordinator for an explanation.

EQUIPMENT SAFETY PRECAUTIONS

WARNING!



KNOW WHERE UTILITIES ARE

Observe overhead electrical and other utility lines. Be sure equipment will clear them. When digging, call your local utilities for location of buried utility lines, gas, water, and sewer, as well as any other hazard you may encounter.



OPERATING THE VIBRATORY ROLLER

Block off work area from bystanders, livestock, etc.

Operate only from the operator's station.

Do not lift loads in excess of the capacity of the prime mover.

When operating on slopes, drive up and down, not across. Avoid steep hillside operation, which could cause the prime mover to overturn.

Reduce speed when driving over rough terrain, on a slope, or turning, to avoid overturning the vehicle.

An operator must not use drugs or alcohol, which can change his or her alertness or coordination. An operator taking prescription or over-the-counter drugs should seek medical advice on whether or not he or she can safely operate equipment.

Before exiting the prime mover, lower the attachment to the ground, turn off the prime mover's engine, remove the key and apply the brakes.



TRANSPORTING THE VIBRATORY ROLLER

Travel only with the attachment in a safe transport position to prevent uncontrolled movement. Drive slowly over rough ground and on slopes.

When driving on public roads use safety lights, reflectors, Slow Moving Vehicle signs etc., to prevent accidents. Check local government regulations that may affect you.

Do not drive close to ditches, excavations, etc., cave in could result.

Do not smoke when refueling the prime mover. Allow room in the gas tank for expansion. Wipe up any spilled fuel. Secure cap tightly when done.



MAINTAINING THE VIBRATORY ROLLER

Before performing maintenance, lower the attachment to the ground, turn off the engine, remove the key and apply the brakes.

Never perform any work on the attachment unless you are authorized and qualified to do so. Always read the operator service manual's before any repair is made.

After completing maintenance or repair, check for correct functioning of the attachment. If not functioning properly, always tag "DO NOT OPERATE" until all problems are corrected.

Worn, damaged, or illegible safety decals must be replaced. New safety decals can be ordered from SPARTAN EQUIPMENT.

Never make hydraulic repairs while the system is under pressure. Serious personal injury or death could result.

Never work under a raised attachment.

DECALS

DECAL PLACEMENT

2.

GENERAL INFORMATION

The diagram on this page shows the location of the decals used on the SPARTAN EQUIPMENT Vibratory Roller. The decals are identified by their part numbers, with reductions of the actual decals located on the following pages. Use this information to order replacements for lost or damaged decals. Be sure to read all decals before operating the attachment. They contain information you need to know for both safety and longevity.

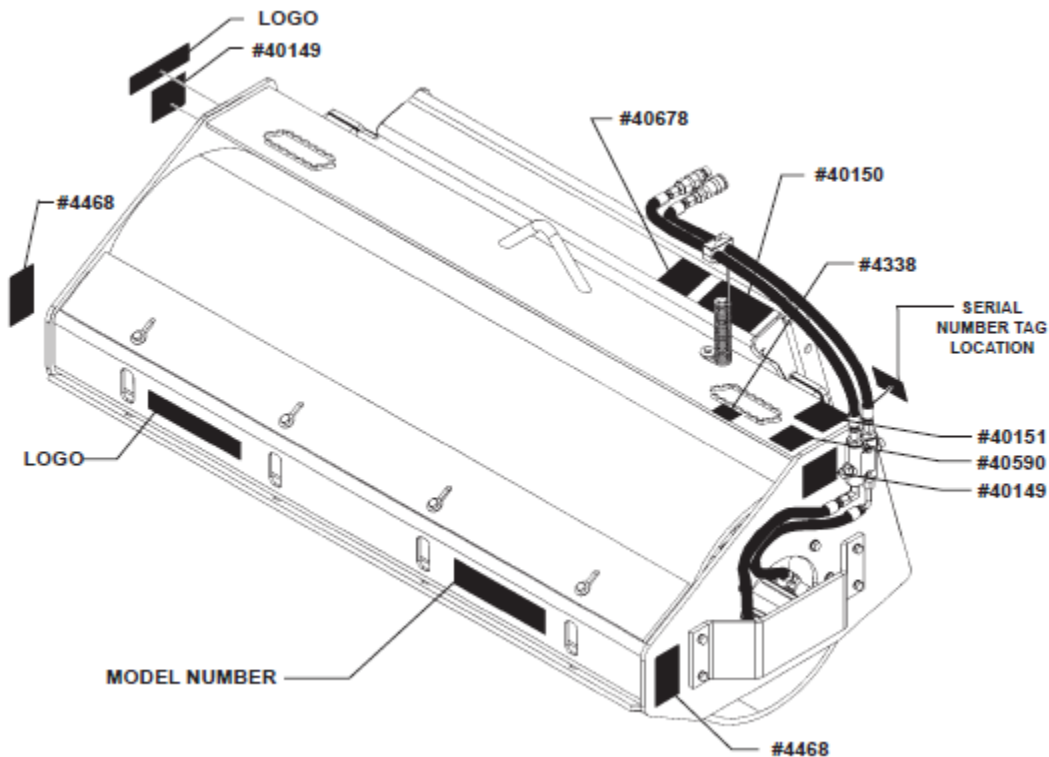

IMPORTANT: Keep all safety signs clean and legible. Replace all missing, illegible, or damaged safety signs. When replacing parts with safety signs attached, the safety signs must also be replaced.

REPLACING SAFETY SIGNS: Clean the area of application with nonflammable solvent, then wash the same area with soap and water. Allow the surface to fully dry. Remove the backing from the safety sign, exposing the adhesive surface. Apply the safety sign to the position shown in the diagram above and smooth out any bubbles.

DECALS

SPARTAN EQUIPMENT LOGO
PART #40113 (SMALL - WHITE)
PART #40092 (LARGE - WHITE)

VRS48

MODEL NUMBER
PART #40892

VRP48

MODEL NUMBER
PART #40896

VRS66

MODEL NUMBER
PART #40893

VRP66

MODEL NUMBER
PART #40897

VRS73

MODEL NUMBER
PART #40894

VRP73

MODEL NUMBER
PART #40898

VRS84

MODEL NUMBER
PART #40895

VRP84

MODEL NUMBER
PART #40899



WARNING

BEFORE LEAVING
OPERATOR'S SEAT:

3. Lower lift arms against frame and place unit on the ground.
4. Disengage auxiliary hydraulics.
5. Stop Engine and Remove Key.
4. Engage Parking Brake. #40678

WARNING! BEFORE LEAVING SEAT
PART #40678



CAUTION

DO NOT OPERATE
USING HI-FLOW
HYDRAULIC SYSTEMS.
Maximum 25 GPM

#40590

CAUTION! HIGH FLOW SYSTEMS
PART #40590

10400 9-16-05

DECALS



WARNING! HIGH PRESSURE FLUID
PART #40151

A DANGER



To prevent serious injury or death from pinching:

- Keep all persons and objects clear while any part of this machine is in motion.

DANGER! PINCH POINT
PART #40149

A WARNING

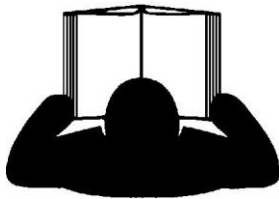

To Prevent Serious Injury or Death

- Avoid unsafe operation or maintenance.
- Do not operate or work on this machine without reading and understanding the operator's manual.
- If manual is lost, contact your nearest dealer for a new manual.

40150

WARNING! READ MANUAL
PART #40150



Keep hands and feet away from under frame. Failure to do so could result in bodily injury.

WARNING! FOOT CRUSH
PART #4468

INSTALLATION

GENERAL INFORMATION

The SPARTAN EQUIPMENT Vibratory Rollers were designed to be easy to use and maintain. They are operated by the loaders auxiliary hydraulics. The Vibratory Rollers mount to the toolbar / quick attach mechanism for easy mounting.

NOTICE: DO NOT operate the Vibratory Rollers on a Hi-Flow hydraulic system (25 GPM Maximum). Damage to the hydraulic motor will occur.

NOMENCLATURE

Throughout this manual, reference is made to various Vibratory Roller components. Study the following diagram to acquaint yourself with the various names of these components. This knowledge will be helpful when reading through this manual or when ordering service parts. There is a complete parts breakdown for each roller at the back of this manual.

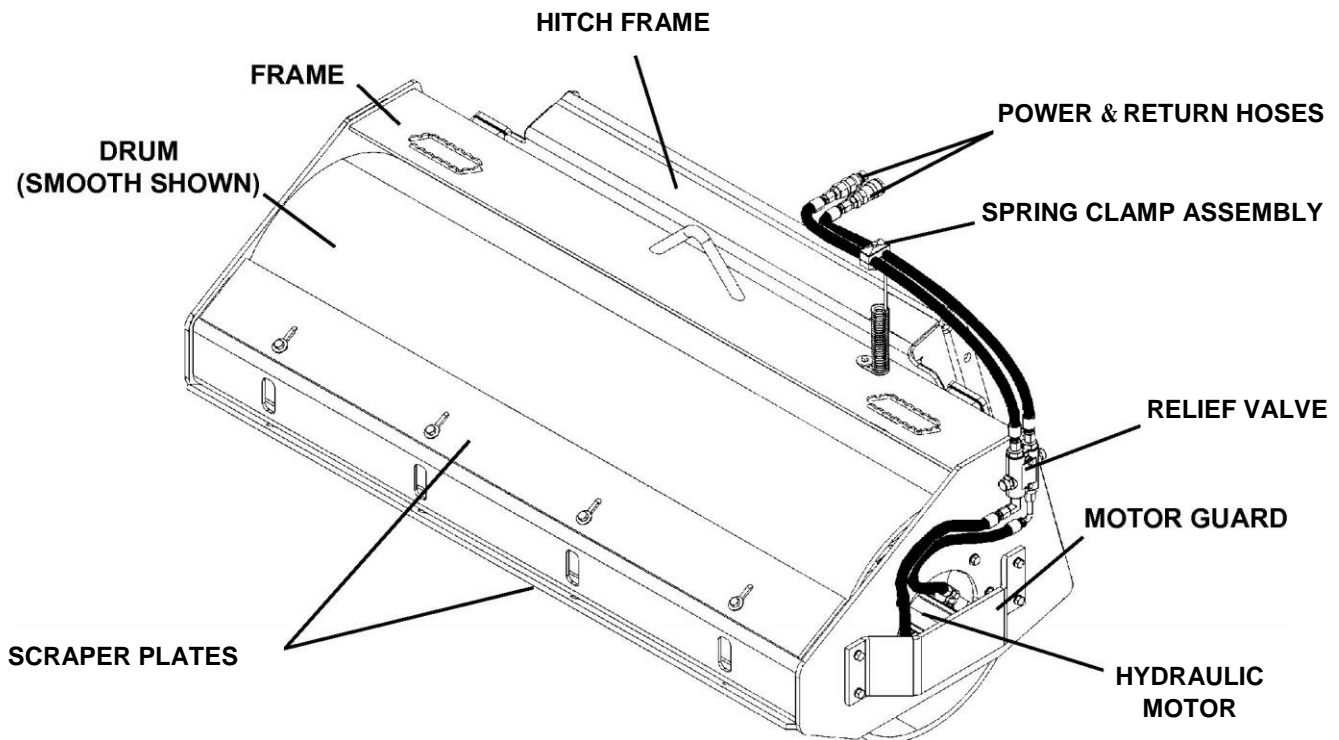

ATTACHING

Install the Vibratory Roller by following your power unit operator's manual for proper installation of an attachment. Connect the power and return hoses to the auxiliary hydraulic couplers on the loader. **IMPORTANT: All hose routings should be check for kinks or pinching. Reroute if necessary.**

WARNING! To Avoid Serious Personal Injury, make sure the Vibratory Roller is securely  latched to the attachment mechanism of your unit. Failure to do so could result in separation of the attachment from the unit.

INSTALLATION

DETACHING

On firm, level ground. Lower the lift arms against the frame and place the roller on the ground.

Move the control levers back and forth to relieve pressure in the line. Disconnect couplers.

NOTE: Connect couplers together or install dust caps and plugs to prevent contaminants from entering the hydraulic system.

Follow your power unit operator's manual for detaching (removing) an attachment.

CAUTION! Block vibratory roller drum to prevent rolling when not attached to loader.



NOTE: Frequent lubrication of grease fittings with a multi-purpose grease will greatly increase the life of the product.

IMPORTANT: DISENGAGE THE AUXILIARY HYDRAULICS, STOP THE ENGINE, AND ENGAGE PARKING BRAKE AND REMOVE KEY BEFORE LEAVING THE OPERATOR'S STATION.

OPERATION

GENERAL INFORMATION

The SPARTAN EQUIPMENT Vibratory Roller is a hydraulically powered attachment designed to compact soil, stone or fill material. Performance of the roller varies greatly depending on the operator and how the attachment is used.

WARNING! Read and understand the Safety Precautions section of this manual before beginning operation.



Operate the attachment only from the operator's station. Any other method could result in serious personal injury or death.

Do not allow bystanders in the area when operating.

Go up and down slopes, not across them. Keep the heavy end of the machine uphill.

Follow mandatory safety shutdown procedures before cleaning, adjusting, lubricating or servicing this attachment.

OPERATING PROCEDURE

1. Position the Vibratory Roller in the desired starting location and lower the attachment to the ground.
2. Lower the loader arms and roll the toolbar out until the top of the roller frame is parallel to the ground and the front tires of the loader are approximately 1-3 inches off the ground.
3. Engage the auxiliary hydraulics on the loader and slowly drive forward.
4. Once you have reached the end of the pass, reverse the skid steer and drive slowly backwards to further pack the soil and cover any tire tracks.

IMPORTANT: The drive circuit is bi-directional but, for the best results it is recommended that you reverse the auxiliary hydraulic flow when you reverse direction.

NOTICE: DO NOT operate the Vibratory Roller on Hi-Flow hydraulic systems (25 GPM maximum). Damage to the hydraulic motor will occur.

MAINTENANCE AND SERVICE

GENERAL INFORMATION

Regular maintenance and service is the key to long equipment life and safe operation. Maintenance requirements have been kept to a minimum. However it is important that these maintenance procedures be performed as described in this section.

WARNING! Read the Safety Precautions section of this manual before performing any maintenance procedure.



Follow all mandatory safety shutdown procedures outlined in the loader operator's manual before adjusting, cleaning, lubricating or servicing this attachment.

EVERY 8 HOURS

- Lubricate all grease fittings. (One grease fitting located on the back of the hitch frame).
- Check bolts for tightness.
- Check hydraulic hoses for leaks, pinching or deterioration.
- Check all safety signs are clean and legible.
- Replace any damaged or worn parts.

WARNING Escaping hydraulic fluid under pressure can have sufficient force to penetrate the skin causing serious personal injury. Fluid escaping from a very small hole can be almost invisible. Use a piece of cardboard or wood rather than your hands to search for suspected leaks.



Keep unprotected body parts, such as face, eyes, and arms as far away as possible from a suspected leak. Flesh injected with hydraulic fluid may develop gangrene or other permanent disabilities.

If injured by injected fluid see a doctor at once. If your doctor is not familiar with this type of injury, ask him to research it immediately to determine proper treatment.

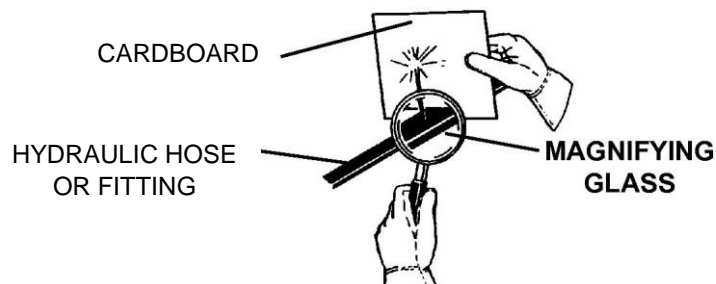

EVERY 100 HOURS

Check oil level in roller shaft. (Remove 90° elbow with fittings in the cover plate. Oil level is sufficient if oil is up to the fill hole. If the unit is level and the oil is not visible, add as required.)

NOTE: The Vibratory Roller is a sealed unit. If oil is low, service is required.

MAINTENANCE AND SERVICE

EVERY 500 HOURS

WARNING! Follow all mandatory safety shutdown procedures outlined in the loader operator's manual before adjusting, cleaning, lubricating or servicing this attachment.



The gear oil in the drive circuit must be changed after every 500 hours of operation with an 80-90 weight gear lube.

TO CHANGE GEAR LUBE:

1. Raise the left side (motor side) of the vibratory roller using a hoist and place a 6" x 6" block under the drum and lower the roller onto the block.
2. On the right side of the vibratory roller, place a container (to catch the oil) under the cover plate and remove the cover plate leaving all fittings in place.
3. Once the oil has been completely drained from the roller shaft, remove the block from the left side of the vibratory roller and place under the right side of the roller.
4. Clean the existing silicone from the cover plate and reseal and replace using new adhesive sealant (100 Silicone Rubber). Check for leaks.
5. Remove the breather plug from the cover plate and fill the roller shaft with the amount of 80-90 weight gear lube recommended for your attachment. (See Oil Requirements below.) Replace breather plug with breather pointing up.

OIL REQUIREMENTS (APPROXIMATE)

48" Vibratory Roller	= 1.38 Quarts
66" Vibratory Roller	= 2.00 Quarts
73" Vibratory Roller	= 2.13 Quarts
84" Vibratory Roller	= 2.50 Quarts

DRUM REMOVAL

NOTE: Removal of the isolator bolts will allow the vibratory roller frame to fall. Make sure the frame is completely supported before removing.

WARNING! NEVER place hands or fingers between the frame and drum assemblies during installation or removal. Severe personal injury could occur.



WARNING! Follow all mandatory safety shutdown procedures outlined in the loader operator's manual before adjusting, cleaning, lubricating or servicing this attachment.



1. Using a loader or hoist, position the unit with the drum on the ground and the frame completely supported on blocks. Remove the motor guard and the motor bolts. Place a container (to catch the oil from the roller shaft) under the motor and remove the motor from the drum assembly. See Figure #1

MAINTENANCE AND SERVICE

10.

FIGURE #1

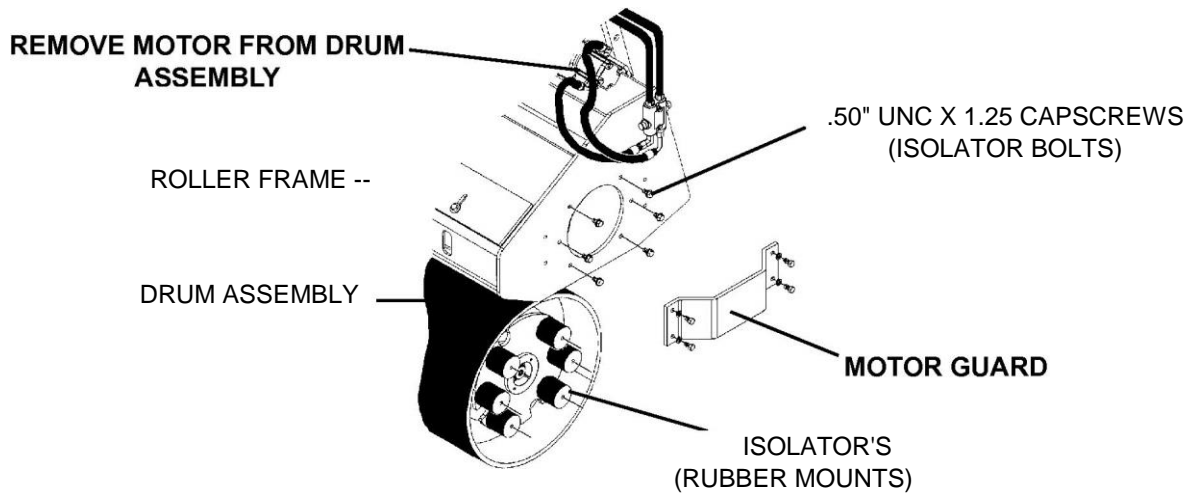

2. Remove the twelve (isolator) bolts securing the roller frame to the drum and isolators. Using the loader or hoist, lift the frame assembly off of the drum assembly and set aside. See Figure #1
3. Use a hoist to finish draining the oil from the roller shaft. Drum removal is complete

DRUM INSTALLATION

1. Lift the roller frame over the top of the drum assembly and into position. Reinstall the twelve .50" UNC x 1.25" capscrews and hard flat washers (using loctite 271 or equivalent) securing the frame to the drum.

WARNING! NEVER place hands or fingers between the frame and drum assemblies during installation or removal. Severe personal injury could occur.

2. Reinstall the hydraulic motor, gasket and motor guard using the existing hardware (using loctite 271 or equivalent on motor mounting hardware).
3. Fill the roller shaft with 80-90 weight gear lube by following the procedure listed in TO CHANGE GEAR LUBE.

REPLACING VIBRATION ISOLATORS (RUBBER MOUNTS)

NOTE: Removal of the isolator bolts will allow the vibratory roller frame to fall. Make sure the frame is completely supported before removing.

WARNING! Follow all mandatory safety shutdown procedures outlined in the loader operator's manual before adjusting, cleaning, lubricating or servicing this attachment.

MAINTENANCE AND SERVICE

1. Remove the drum by following the procedure listed for **DRUM REMOVAL**.
2. Remove the .50" UNC deformed lock nuts securing the isolators to the left and right hubs and install new isolators. Torque nuts to 55 ft. lbs.

NOTICE: Do NOT remove the hubs from the roller shaft. Removing the hubs without first supporting the roller shaft will cause damage to the roller shaft seal sleeves.

3. Install the drum by following the procedure listed for **DRUM INSTALLATION**.

WARNING! NEVER place hands or fingers between the frame and drum assemblies during installation or removal. Severe personal injury could occur.

REPLACING LEFT BEARINGS AND/OR HUBS

WARNING! Follow all mandatory safety shutdown procedures outlined in the loader operator's manual before adjusting, cleaning, lubricating or servicing this attachment.



1. Remove the drum by following the procedure listed for **DRUM REMOVAL**.
2. Remove the bearing spacer, lock washer and lock nut from the end of the roller shaft by first bending back the engaged tab on the lock washer.
3. Insert a clean .62" rod into the motor end of the roller shaft and support the shaft in its current position.

NOTICE: Removing the hubs without first supporting the roller shaft will cause damage to the roller shaft seal sleeves.

4. Remove the outer bearing hub mounting bolts and slide both bearing hubs out and over the end of the rod while keeping the roller shaft firmly supported.

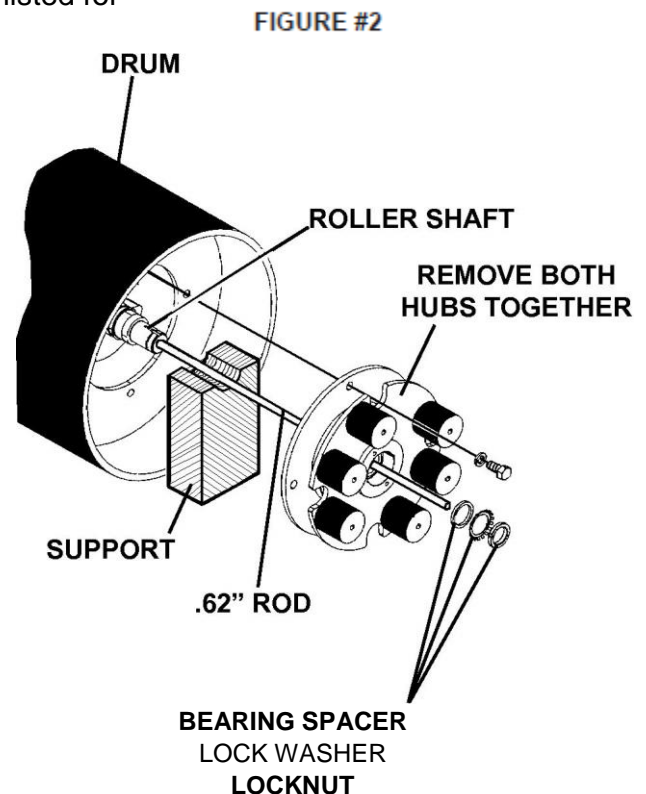

11.

MAINTENANCE AND SERVICE

NOTICE: DO NOT LET THE ROLLER SHAFT DROP AND COME INTO CONTACT WITH THE DRUM OR HUB. SEAL SLEEVE DAMAGE COULD OCCUR.

NOTICE: Shaft and bearing hubs are heavy. Be careful not to drop one on the other as denting may occur.

5. Pull the inner bearing hub out of the outer bearing hub. Remove the oil seal and snap ring from the end of the left inner hub. Tilt the housing to allow each bearing cone to fallout. See Figure #3

6. The bearing cup will need to be removed and replaced using an industrial press. Install new bearing cones. See Figure #3

7. Reinstall the snap ring and press on the new oil seal. See Figure #3

8. Remove the bearing retainer from the outer hub and using an industrial press, remove and replace the outer bearing. See Figure #3

9. Reinstall the bearing retainer using the existing hardware. See Figure #3

10. Apply a small amount of oil or grease to the outer bearing hub and using an industrial press assemble the outer bearing hub to the inner bearing hub.

11. While maintaining support of the roller shaft, slide the hub assemblies over the .62" rod and install securely- to the drum using the existing .75" UNC X 1.50" capscrews removed in step #5.

12. Reinstall the bearing spacer, lock washer and lock nut onto the end of the roller shaft. Torque the nut to 15 ft. lbs .. Be sure to fully engage the tab on the lock washer into the slot on the shaft nut.

13. Install the drum by following the procedure listed for **DRUM INSTALLATION**.

WARNING! NEVER place hands or fingers between the frame and drum assemblies during installation or removal. Severe personal injury could occur.



FIGURE #3

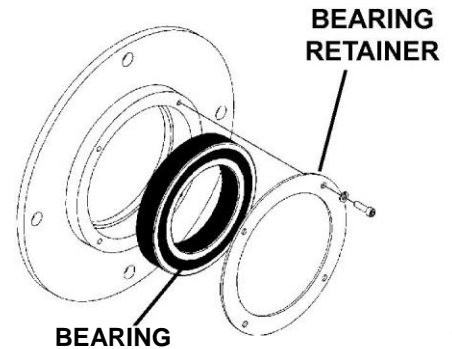

OUTER HUB AND BEARING

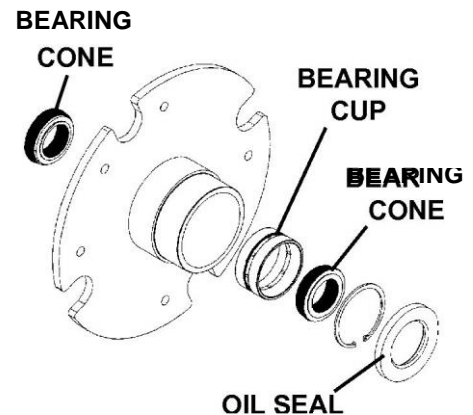

LEFT INNER HUB AND BEARINGS

MAINTENANCE AND SERVICE

REPLACING RIGHT BEARINGS AND/OR HUBS

WARNING! Follow all mandatory safety shutdown procedures outlined in the loader operator's manual before adjusting, cleaning, lubricating or servicing this attachment.



1. Remove the drum by following the procedure listed for **DRUM REMOVAL**.
2. Remove the cover plate with fittings. See Figure #4
3. Insert a clean .75" rod into the end of the roller shaft and support the shaft in its current position. See Figure #4

NOTICE: Removing the hubs without first supporting the roller shaft will cause damage to the roller shaft seal sleeves.

4. Remove the outer bearing hub mounting bolts and slide both bearing hubs out and over the end of the rod while keeping the roller shaft firmly supported. See Figure #4

NOTICE: DO NOT LET THE ROLLER SHAFT DROP AND COME INTO CONTACT WITH THE DRUM OR HUB. SEAL SLEEVE DAMAGE COULD OCCUR.

NOTICE: Shaft and bearing hubs are heavy. Be careful not to drop one on the other as denting may occur.

FIGURE #4

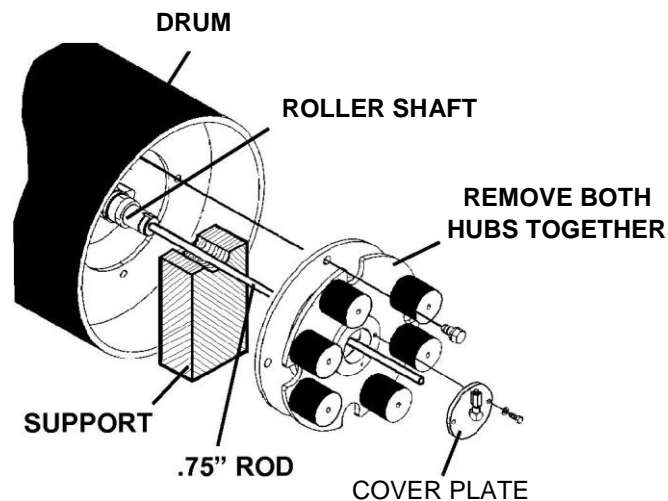

5. Remove the oil seal and snap ring from the end of the right inner hub. See Figure #5
6. Replacing Right Inner Hub Bearings:
 - a. If your unit is equipped with a spherical bearing, remove bearing and replace with two #107605 bearings and one #107387 spacer using an industrial press. Install new bearings. See Figure #5
 - b. If your unit is equipped with the two roller bearings and spacer, remove bearings and spacer and replace using an industrial press. Install new bearings. See Figure #5
 - c. If your unit is equipped with two ball bearings (no spacer), replace the complete right side inner hub assembly #104805.
7. Reinstall the snap ring and press on the new oil seal. See Figure #5

MAINTENANCE AND SERVICE

14.

8. Remove the bearing retainer from the outer hub and using an industrial press, remove and replace the outer bearing. See Figure #5
9. Reinstall the bearing retainer using the existing hardware. See Figure #5
10. Apply a small amount of oil or grease to the outer bearing hub and using an industrial press assemble the outer bearing hub to the inner bearing hub.
12. While maintaining support of the roller shaft, slide the hub assemblies over the .75" rod and secure to the drum using the existing .75" UNC X 1.50" capscrews removed in step #4.
13. Reinstall the cover plate
12. Install the drum by following the procedure listed for **DRUM INSTALLATION**.

WARNING! NEVER place hands or fingers between



the frame and drum assemblies during installation or removal. Severe personal injury could occur.

HYDRAULIC MOTOR REPLACEMENT

WARNING! Follow all mandatory safety shutdown procedures outlined in the loader



operator's manual before adjusting, cleaning, lubricating or servicing this attachment.

1. Place a block under the left side of the vibratory roller and disconnect the hydraulic couplers from the loader. Remove the motor guard and the motor bolts. Tag and disconnect the hydraulic hoses from the hydraulic motor. Note the hose routing for re-installation.

NOTE: IT IS RECOMMENDED THAT THE MOTOR GASKET BE REPLACED AT THE SAME TIME AS THE HYDRAULIC MOTOR.

NOTE: THE UPDATED HYDRAULIC MOTOR HAS A CAST HOUSING INSTEAD OF ALUMINUM. IF UPDATING YOUR UNIT YOU MUST ALSO REPLACE THE 10MBO-8MJ ELBOW WITH A 12MBO-8MJ ELBOW PART #3316 (GOING TO HOSE #38343).

2. Remove the motor and gasket from the drum assembly and replace with the new hydraulic motor and gasket. Reconnect the hydraulic hoses and fittings to the new motor.

NOTE: FIELD REPLACEMENT OF THE INTERNAL MOTOR SEALS VOIDS WARRANTY.

3. Check for leaks. Reinstall the motor bolts and the motor guard.
4. Check oil level in roller shaft and fill as needed with 80-90 weight gear lube.

FIGURE #5

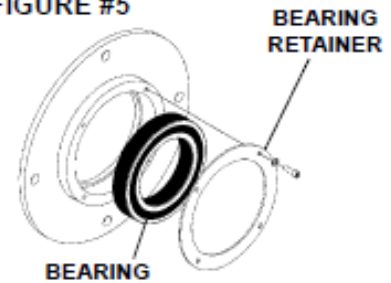

OUTER HUB AND BEARING

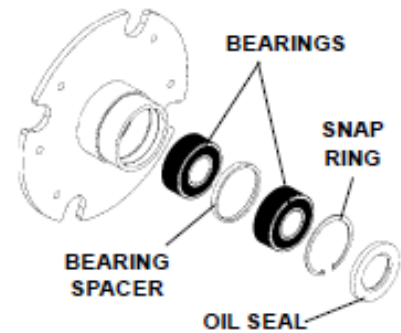

RIGHT INNER HUB AND BEARINGS

TROUBLESHOOTING

PROBLEM	POSSIBLE CAUSE	REMEDY
Insufficient compaction	Loader "down pressure" insufficient	Increase the "down pressure" by raising the front wheels off the ground (see Operation)
	Operating RPM too slow	Increase RPM to half throttle
Does not vibrate	Hydraulic couplers malfunctioning	Replace
	Hydraulic couplers not completely engaged	Check and tighten couplers
	Hydraulic motor damaged	Replace motor
	Relief Valve damaged	Replace Relief Valve
	Roller shaft bearings damaged	Replace
	Low oil supply	Check for oil leaks and service as required
Excessive noise and/or vibration	Isolator's worn	Replace Isolators
	Operating RPM too slow	Increase RPM to half throttle
	Hydraulic motor damaged	Replace
Oil leaking	Oil seals damaged	Replace
	Relief Valve damaged	Replace
	Hydraulic motor damaged	Replace
	Bearings damaged	Replace (replace oil seals at the same time)
	Broken or loose hydraulic lines or fittings	Check for leaks and repair or replace
Drum will not turn	Frame Installed Incorrectly	Check frame for correct installation and all hardware intact.
	Bearings damaged	Replace
	Binding between frame and drum.	Remove
Vibratory roller not tilting correctly	Guide retainer on hitch too loose or too tight	Add or remove shims from hitch

10416 9-26-05



BOLT TORQUE

BOLT TORQUE SPECIFICATIONS

GENERAL TORQUE SPECIFICATION TABLE

Use the following torques when special torques are not given. These values apply to fasteners as received from suppliers, dry, or when lubricated with normal engine oil. They do not apply if special graphited or moly disulphide greases or other extreme pressure lubricants are used. This applies to both UNF and UNC threads. Remember to always use grade five or better when replacing bolts.

IMPORTANT: On all PLATED GRADE 8 bolts, reduce torque 15 from listed bolt torque specification.

SAE Grade No.		2						5				8*			
Bolt head identification marks as per grade. NOTE: Manufacturing Marks Will Vary															
		TORQUE		TORQUE		TORQUE		TORQUE		TORQUE		TORQUE			
Bolt Size		Pounds Feet		Newton-Meters		Pounds Feet		Newton-Meters		Pounds Feet		Newton-Meters			
Inches	Millimeters	Min.	Max.	Min.	Max.	Min.	Max.	Min.	Max.	Min.	Max.	Min.	Max.		
1/4	6.35	5	6	7	8	9	11	12	15	12	15	16	2		
5/16	7.94	10	12	14	16	17	20.5	23	28	24	29	33	3		
3/8	9.53	20	23	27	31	35	42	48	57	45	54	61	7		
7/16	11.11	30	35	41	47	54	64	73	87	70	84	95	11		
1/2	12.70	45	52	61	70	80	96	109	130	110	132	149	17		
9/16	14.29	65	75	88	102	110	132	145	179	160	192	217	26		
5/8	15.88	95	105	129	142	150	180	203	244	220	264	298	35		
3/4	19.05	150	185	203	251	270	324	366	439	380	456	515	61		
7/8	22.23	160	200	217	271	400	480	542	651	600	720	814	97		
1	25.40	250	300	339	406	580	696	787	944	900	1080	1220	146		
1-1/8	25.58	-	-	-	-	800	880	1085	1193	1280	1440	1736	195		
1-1/4	31.75	-	-	-	-	1120	1240	1519	1681	1820	2000	2468	271		
1-3/8	34.93	-	-	-	-	1460	1680	1980	2278	2380	2720	3227	368		
1-1/2	38.10	-	-	-	-	1940	2200	2631	2983	3160	3560	4285	482		

* Thick Nuts must be used with Grade 8 bolts

METRIC BOLT TORQUE SPECIFICATIONS

Size of Screw	Grade No.	5.6			8.8			10.9		
		Coarse Thread			Fine Thread					
		Pitch (mm)	Pounds Feet	Newton-Meters	Pitch (mm)	Pounds Feet	Newton-Meters			
M6	5.6	1.0	3.6-5.8	4.9-7.9	-	-	-	-	-	-
	8.8		5.8-4	7.9-12.7		-	-			
	10.9		7.2-10	9.8-13.6		-	-			
M8	5.6	1.25	7.2-14	9.8-19	1.0	12-17	16.3-23	1.0	-	-
	8.8		17-22	23-29.8		19-27	25.7-36.6			
	10.9		20-26	27.1-35.2		22-31	29.8-42			
M10	5.6	1.5	20-25	27.1-33.9	1.25	20-29	27.1-39.3	1.25	-	-
	8.8		34-40	46.1-54.2		35-47	47.4-63.7			
	10.9		38-46	51.5-62.3		40-52	54.2-70.5			
M12	5.6	1.75	28-34	37.9-46.1	1.25	31-41	42-55.6	1.25	-	-
	8.8		51-59	69.1-79.9		56-68	75.9-92.1			
	10.9		57-66	77.2-89.4		62-75	84-101.6			
M14	5.6	2.0	49-56	66.4-75.9	1.5	52-64	70.5-86.7	1.5	-	-
	8.8		81-93	109.8-126		90-106	122-143.6			
	10.9		96-109	130.1-147.7		107-124	145-168			
M16	5.6	2.0	67-77	90.8-104.3	1.5	69-83	93.5-112.5	1.5	-	-
	8.8		116-130	157.2-176.2		120-138	162.6-187			
	10.9		129-145	174.8-196.5		140-158	183.7-214.1			
M18	5.6	2.0	88-100	119.2-136	1.5	100-117	136-158.5	1.5	-	-
	8.8		150-168	203.3-227.6		177-199	239.8-269.6			
	10.9		175-194	237.1-262.9		202-231	273.7-313			
M20	5.6	2.5	108-130	146.3-176.2	1.5	132-150	178.9-203.3	1.5	-	-
	8.8		186-205	252-277.8		206-242	279.1-327.9			
	10.9		213-249	288.6-337.4		246-289	333.3-391.6			

SPECIFICATIONS

VIBRATORY ROLLER

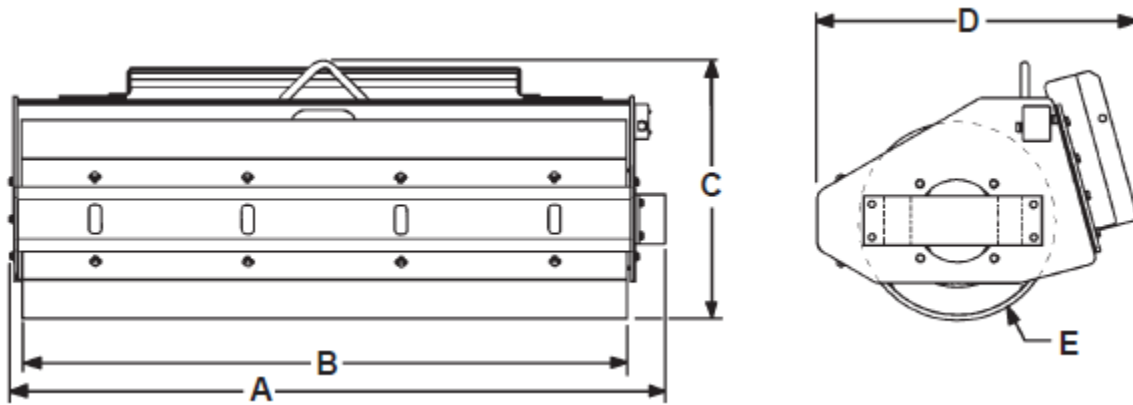

SPECIFICATION AND DESIGN ARE SUBJECT TO CHANGE WITHOUT NOTICE AND WITHOUT LIABILITY THEREFORE.

SMOOTH VIBRATORY ROLLERS

	VR548	VR566	VR573	VR584
A. Overall Width	61.00"	72.00"	79.00"	90.00"
B. Drum Width	48.00"	66.00"	73.00"	84.00"
C. Overall Height..	31.00"	31.00"	31.00"	31.00"
D. Overall Length	39.00"	39.00"	39.00"	39.00"
E. Drum Diameter	24.00"	24.00"	24.00"	24.00"
Operating Weight (lbs)	1680#	2150#	2300#	2530#
Dynamic Force (lbs)	5750#	7800#	8550#	9370#
Vibrating Speed (vpm)	2600	2600	2600	2600
Vibrating Weight (lbs)	935#	1190#	1290#	1440#
Drum Oscillation/Tilt (degrees)	15°	15°	15°	15°
Maximum Flow (gpm)	25	25	25	25

PADDED VIBRATORY ROLLERS

	VRP48	VRP66	VRP73	VRP84
A. Overall Width	61.00"	72.00"	79.00"	90.00"
B. Drum Width	48.00"	66.00"	73.00"	84.00"
C. Overall Height..	31.00"	31.00"	31.00"	31.00"
D. Overall Length	39.00"	39.00"	39.00"	39.00"
E. Drum Diameter (Without Pads)	20.00"	20.00"	20.00"	20.00"
Operating Weight (lbs)	1630#	2085#	2230#	2455#
Dynamic Force (lbs)	5750#	7800#	8550#	9370#
Vibrating Speed (vpm)	2600	2600	2600	2600
Vibrating Weight (lbs)	890#	1130#	1225#	1370#
Drum Oscillation/Tilt (degrees)	15°	15°	15°	15°
Maximum Flow (gpm)	25	25	25	25

NOTE: Specifications are based on 20 GPM hydraulic flow wherever applicable.

NOTE: VRS48 and VRP48 can be center mounted or offset 12.00" to the right.

Limited Warranty

Except for the Excluded Products as described below, all new products are warranted to be free from defects in material and/or workmanship during the Warranty Period, in accordance with and subject to the terms and conditions of this Limited Warranty.

1. Excluded Products. The following products are excluded from this Limited Warranty:

(a) Any cable, part that engages with the ground (i.e. sprockets), digging chain, bearing, teeth, tamping and/or demolition head, blade cutting edge, pilot bit, auger teeth and broom brush that either constitutes or is part of a product.

(b) Any product, merchandise or component that, in the opinion of Spartan Equipment', has been (i) misused; (ii) modified in any unauthorized manner; (iii) altered; (iv) damaged; (v) involved in an accident; or (vi) repaired using parts not obtained through Spartan Equipment.

2. Warranty Period. The Limited Warranty is provided only to those defects that occur during the Warranty Period, which is the period that begins on the first to occur of: (i) the date of initial purchase by an end-user, (ii) the date the product is first leased or rented, or (iii) the date that is six (6) months after the date of shipment by Spartan Equipment as evidenced by the invoiced shipment date (the "Commencement Date") and ends on the date that is twelve (12) months after the Commencement Date.

3. Terms and Conditions of Limited Warranty. The following terms and conditions apply to the Limited Warranty hereby provided:

(a) Option to Repair or Replace. Spartan Equipment shall have the option to repair or replace the product.

(b) Timely Repair and Notice. In order to obtain the Limited Warranty, (i) the product must be repaired within thirty (30) days from the date of failure, and (ii) a claim under the warranty must be submitted to Spartan Equipment in writing within thirty (30) days from the date of repair.

(c) Return of Defective Part or Product. If requested by Spartan Equipment, the alleged defective part or product shall be shipped to Spartan Equipment at its manufacturing facility or other location specified by Spartan Equipment, with freight PRE-PAID by the claimant, to allow Spartan Equipment to inspect the part or product.

Claims that fail to comply with any of the above terms and conditions shall be denied.

LIMITATIONS AND EXCLUSIONS.

THIS LIMITED WARRANTY IS IN LIEU OF ALL OTHER WARRANTIES, EXPRESS OR IMPLIED, INCLUDING WITHOUT LIMITATION THE WARRANTIES OF MERCHANTABILITY, FITNESS FOR A PARTICULAR PURPOSE AND ANY WARRANTY BASED ON A COURSE OF DEALING OR USAGE OF TRADE.

IN NO EVENT SHALL SPARTAN EQUIPMENT BE LIABLE FOR CONSEQUENTIAL OR SPECIAL DAMAGES.

IN NO EVENT SHALL SPARTAN EQUIPMENT BE LIABLE FOR ANY LOSS OR CLAIM IN AN AMOUNT IN EXCESS OF THE PURCHASE PRICE, OR, AT THE OPTION OF SPARTAN EQUIPMENT, THE REPAIR OR REPLACEMENT, OF THE PARTICULAR PRODUCT ON WHICH ANY CLAIM OF LOSS OR DAMAGE IS BASED. THIS LIMITATION OF LIABILITY APPLIES IRRESPECTIVE OF WHETHER THE CLAIM IS BASED ON BREACH OF CONTRACT, BREACH OF WARRANTY, NEGLIGENCE OR OTHER CAUSE AND WHETHER THE ALLEGED DEFECT IS DISCOVERABLE OR LATENT.

16.

SMOOTH VIBRATORY ROLLER ASSEMBLIES

48" ASSEMBLY #105085, 66" ASSEMBLY #105086,
73" ASSEMBLY #105087, 84" ASSEMBLY #105088

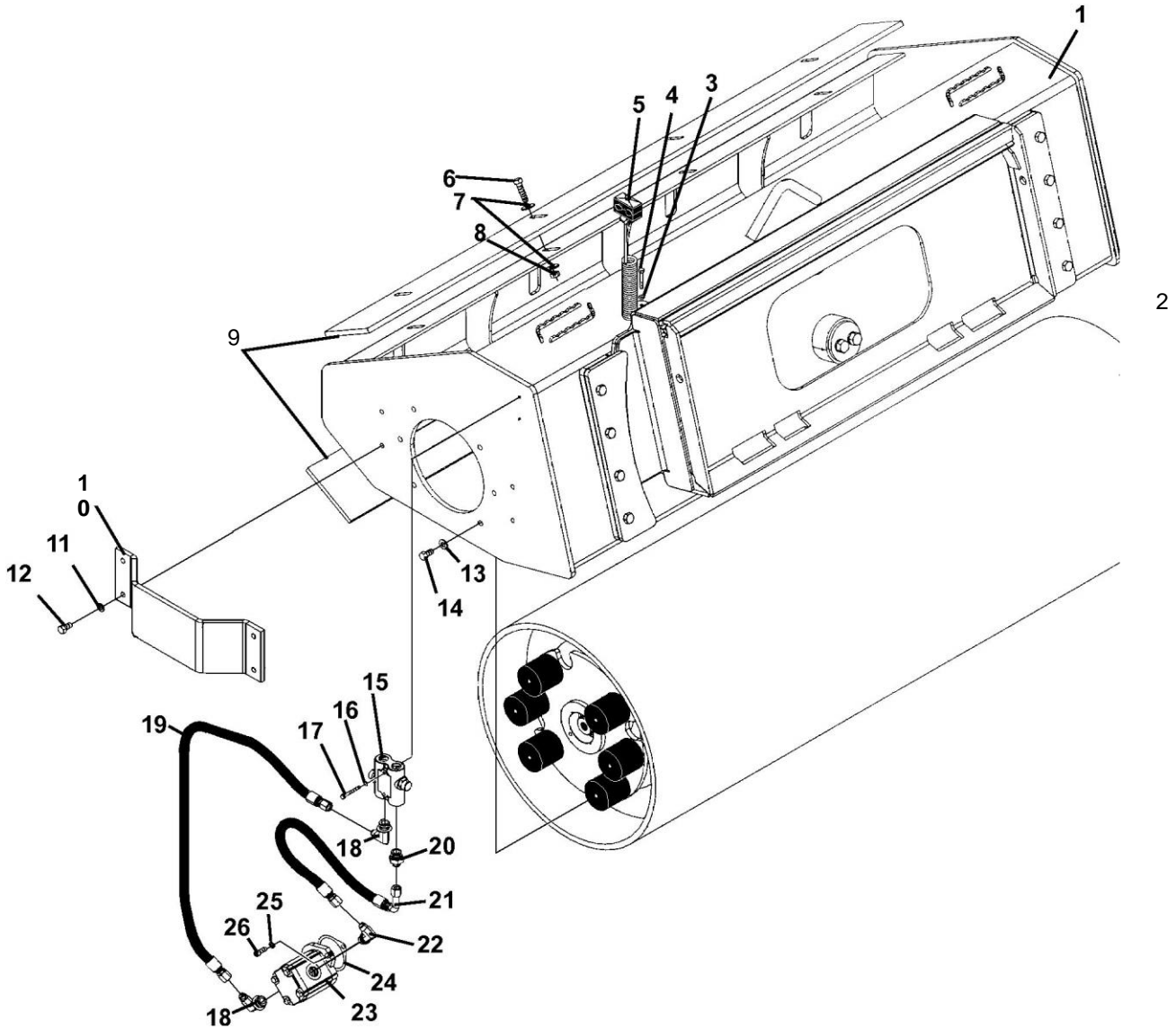

10402 2-19-08-3

SMOOTH VIBRATORY ROLLER ASSEMBLIES

48" ASSEMBLY #105085, 66" ASSEMBLY #105086,

73" ASSEMBLY #105087, 84" ASSEMBLY #105088

ITEM	REQ'D	PART NO.	DESCRIPTION
1	1	105096	48" Frame Assembly
	1	105097	66" Frame Assembly
	1	105098	73" Frame Assembly
	1	105099	84" Frame Assembly
2	1	105100	48" Smooth Drum Assembly
	1	105101	66" Smooth Drum Assembly
	1	105102	73" Smooth Drum Assembly
	1	105103	84" Smooth Drum Assembly
3	1	1502	.31" Lock Washer
4	1	1023	.31" UNC X 1.25" Hex Capscrew
5	1	103179	Spring Clamp Assembly
6	6	1092	.50" UNC X 2.00" Hex Capscrew (48")
	8	1092	.50" UNC X 2.00" Hex Capscrew (66",73" & 84")
7	12	1516	.50" Flat Washer (48")
	16	1516	.50" Flat Washer (66",73" & 84")
8	6	1841	.50" UNC Deformed Lock Nut (48")
	8	1841	.50" UNC Deformed Lock Nut (66",73" & 84")
9	2	105140	48" Scraper Plate
	2	105141	66" Scraper Plate
	2	105142	73" Scraper Plate
	2	105143	84" Scraper Plate
10	1	101958	Motor Guard
11	4	1505	.50" Lock Washer
12	4	1088	.50" UNC X 1.00" Hex Capscrew
13	12	1646	.50" Hard Flat Washer
14	12	1089	.50" UNC X 1.25" Hex Capscrew
15	1	11755	Cross Port Relief Valve
16	2	1501	.50" Lock Washer
17	2	1009	.25" UNC X 2.50" Hex Capscrew
18	2	3316	90° Elbow 12MBo-8MJ
19	1	35474	Hose Assembly .50" X 28" 8FJX-8FJX
20	1	3102	Straight Connector 12MBo-8MJ
21	1	38343	Hose Assembly .50" X 28" 8FJX-8FJX 90° Long
22	1	3316*	90° Elbow 12MBO-8MJ
		3283	90° Elbow 10MBo-8MJ (Replacement for aluminum motors ONLY)
23	1	110918*	Hydraulic Motor (48" & 66" Vibratory Rollers)
	1	110919*	Hydraulic Motor (73" Vibratory Rollers)
	1	110920*	Hydarulic Motor (84" Vibratory Rollers)
24	1	22532	Motor Gasket
25	2	10093	.38" Special Lock Washer
26	2	1708	.38" UNC X 1.00" Socket Head Capscrew

*NOTE: The hydraulic motors have been updated to a cast housing instead of aluminum. If ordering a new cast housing motor you must also replace the #3283 elbow (#22) with a #3316 elbow.

PADDED VIBRATORY ROLLER ASSEMBLIES

48" ASSEMBLY #105089, 66" ASSEMBLY #105090,
73" ASSEMBLY #105091, 84" ASSEMBLY #105092

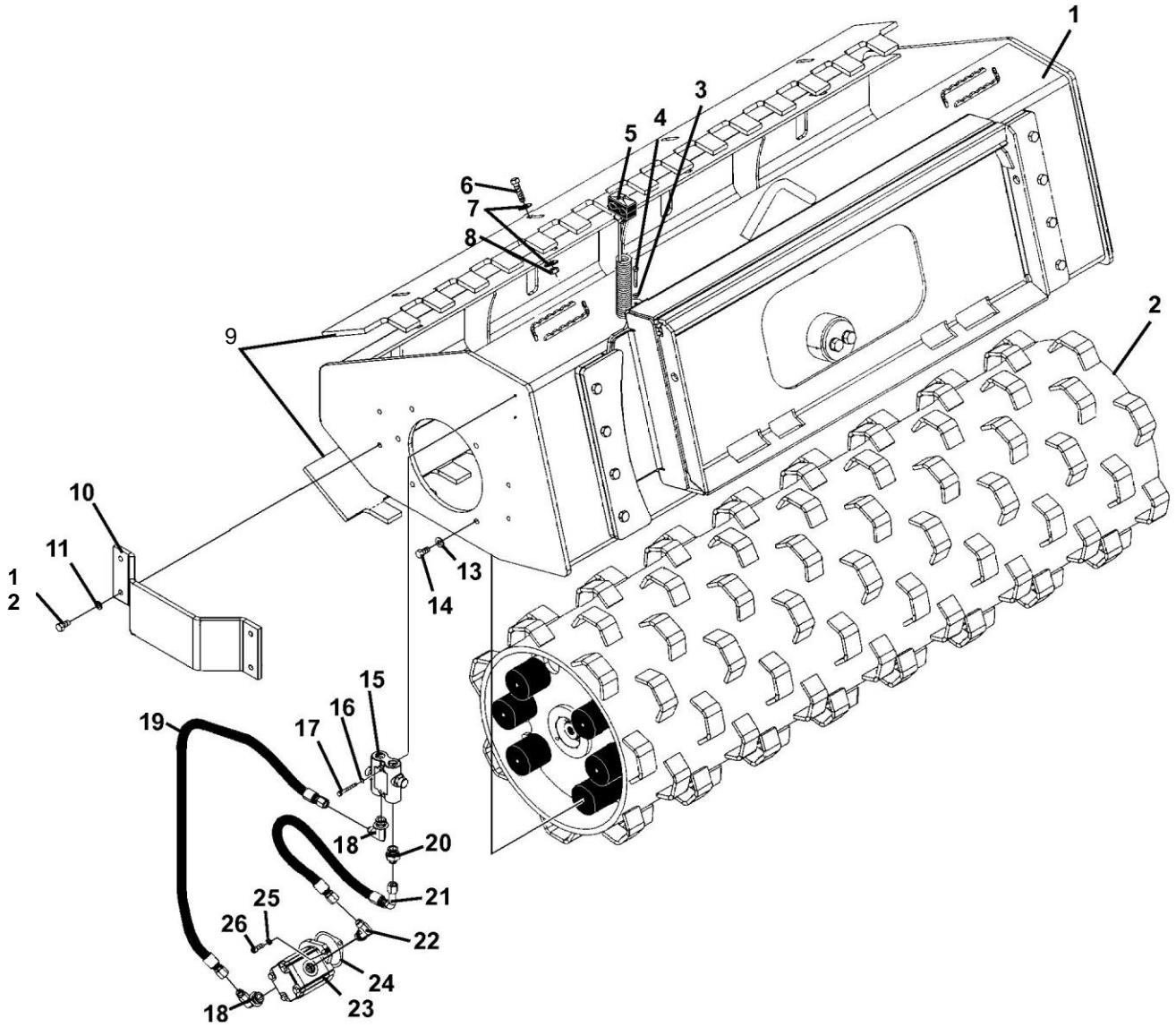

PADDED VIBRATORY ROLLER ASSEMBLIES

48" ASSEMBLY #105089, 66" ASSEMBLY #105090,

73" ASSEMBLY #105091, 84" ASSEMBLY #105092

ITEM	REQ'D	PART NO.	DESCRIPTION
1	1	105096	48" Frame Assembly
	1	105097	66" Frame Assembly
	1	105098	73" Frame Assembly
	1	105099	84" Frame Assembly
2	1	105104	48" Padded Drum Assembly
	1	105105	66" Padded Drum Assembly
	1	105106	73" Padded Drum Assembly
	1	105107	84" Padded Drum Assembly
3	1	1502	.31" Lock Washer
4	1	1023	.31" UNC X 1.25" Hex Capscrew
5	1	103179	Spring Clamp Assembly
6	6	1092	.50" UNC X 2.00" Hex Capscrew (48")
	8	1092	.50" UNC X 2.00" Hex Capscrew (66",73" & 84")
7	12	1516	.50" Flat Washer (48")
	16	1516	.50" Flat Washer (66",73" & 84")
8	6	1841	.50" UNC Deformed Lock Nut (48")
	8	1841	.50" UNC Deformed Lock Nut (66",73" & 84")
9	2	105187	48" Scraper Plate
	2	105188	66" Scraper Plate
	2	105189	73" Scraper Plate
	2	105190	84" Scraper Plate
10	1	101958	Motor Guard
11	4	1505	.50" Lock Washer
12	4	1088	.50" UNC X 1.00" Hex Capscrew
13	12	1646	.50" Hard Flat Washer
14	12	1089	.50" UNC X 1.25" Hex Capscrew
15	1	11755	Cross Port Relief Valve
16	2	1501	.50" Lock Washer
17	2	1009	.25" UNC X 2.50" Hex Capscrew
18	2	3316	90° Elbow 12MBo-8MJ
19	1	35474	Hose Assembly .50" X 28" 8FJX-8FJX
20	1	3102	Straight Connector 12MBo-8MJ
21	1	38343	Hose Assembly .50" X 28" 8FJX-8FJX 90° Long
22	1	3316*	90° Elbow 12MBO-8MJ
		3283	90° Elbow 10MBo-8MJ (Replacement for aluminum motors ONLY)
23	1	110918*	Hydraulic Motor (48" & 66" Vibratory Rollers)
	1	110919*	Hydraulic Motor (73" Vibratory Rollers)
	1	110920*	Hydarulic Motor (84" Vibratory Rollers)
24	1	22532	Motor Gasket
25	2	10093	.38" Special Lock Washer
26	2	1708	.38" UNC X 1.00" Socket Head Capscrew

*NOTE: The hydraulic motors have been updated to a cast housing instead of aluminum. If ordering a new cast housing motor you must also replace the #3283 elbow (#22) with a #3316 elbow.

SPRING CLAMP ASSEMBLY

ASSEMBLY #103179

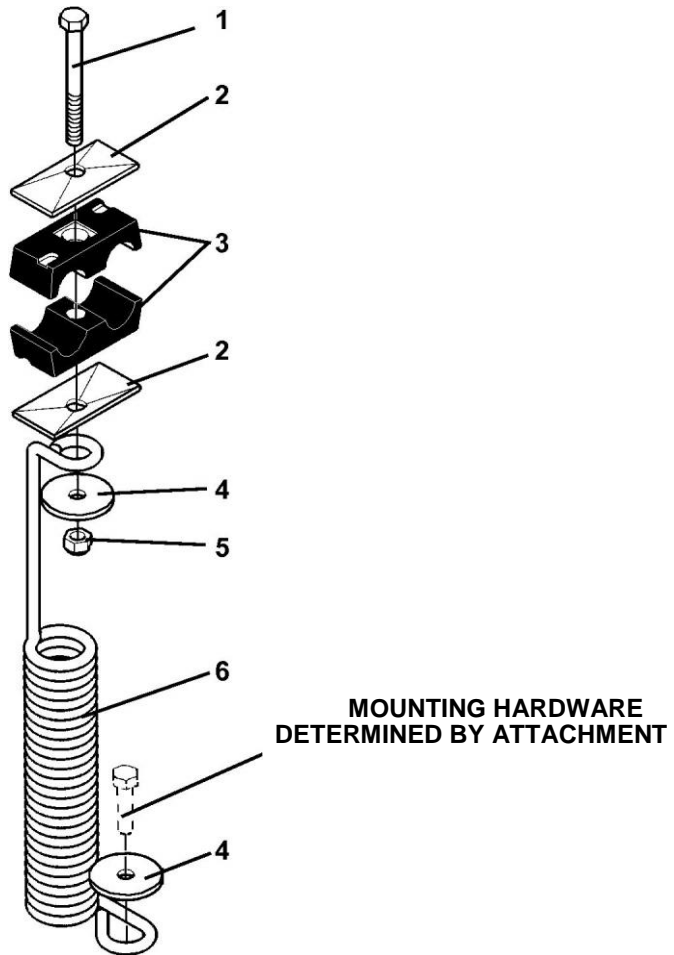

SPRING CLAMP ASSEMBLY

ASSEMBLY #103179

<u>ITEM</u>	<u>REQ'D</u>	<u>PART NO.</u>	<u>DESCRIPTION</u>
1	1	1030	.31" UNC X 3.00" Hex Capscrew
2	2	103184	Top Plate
3	1	103182	Hose Clamp (.88" 10 Hose)
4	2	105840	Fender Washer
5	1	1753	.31" UNC Nylock Nut
6	1	RHW8618	Mounting Spring

10415 4-9-10-2

FRAME ASSEMBLIES

48" ASSEMBLY #105096, 66" ASSEMBLY #105097,
73" ASSEMBLY #105098, 84" ASSEMBLY #105099

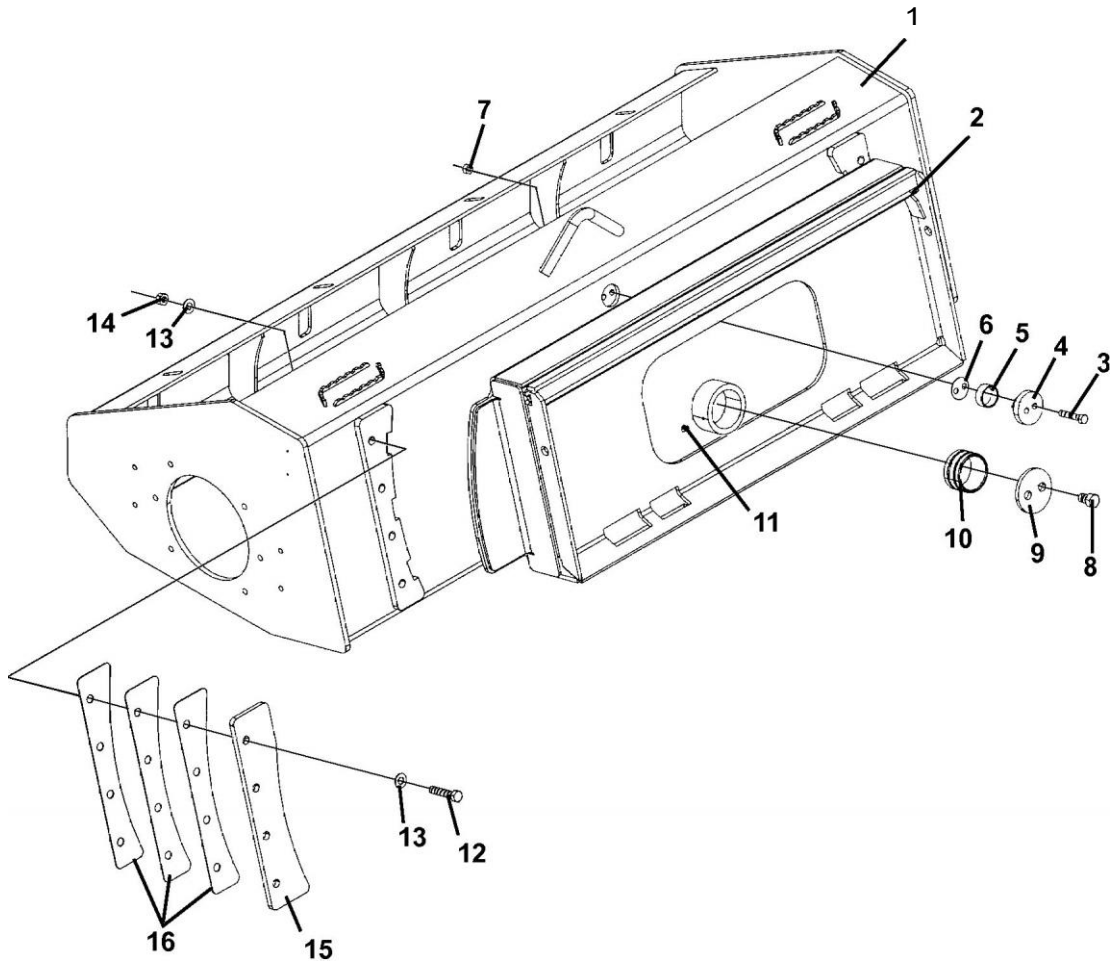

FRAME ASSEMBLIES

48" ASSEMBLY #105096, 66" ASSEMBLY #105097,
73" ASSEMBLY #105098, 84" ASSEMBLY #105099

<u>ITEM</u>	<u>REQ'D</u>	<u>PART NO.</u>	<u>DESCRIPTION</u>
1	1	105112	48" Roller Frame
	1	105113	66" Roller Frame
	1	105114	73" Roller Frame
	1	105115	84" Roller Frame
2	1	105116	Hitch Frame (48")
	1	101682	Hitch Frame (66", 73" & 84")
3	2	1095	.50" UNC X 2.75" Hex Capscrew
4	1	17728	Stop Pin
5	1	101467	Spacer Tube
6	1	104819	Spacer Plate
7	2	1841	.50" UNC Deformed Lock Nut
8	2	1548	.50" UNC X 1.25" Nylock Bolt
9	1	88996	Cap Plate
10	1	89436	Bushing
11	1	53031	90° Grease Fitting
12	8	1119	.62" UNC X 2.75" Hex Capscrew
13	16	1627	.62" Hard Flat Washer
14	8	1839	.62" UNC Deformed Lock Nut
15	2	104179	Guide Retainer
16	6	104181	Guide Shim

SMOOTH DRUM ASSEMBLIES

48" ASSEMBLY #105100, 66" ASSEMBLY #105101,
73" ASSEMBLY #105102, 84" ASSEMBLY #105103

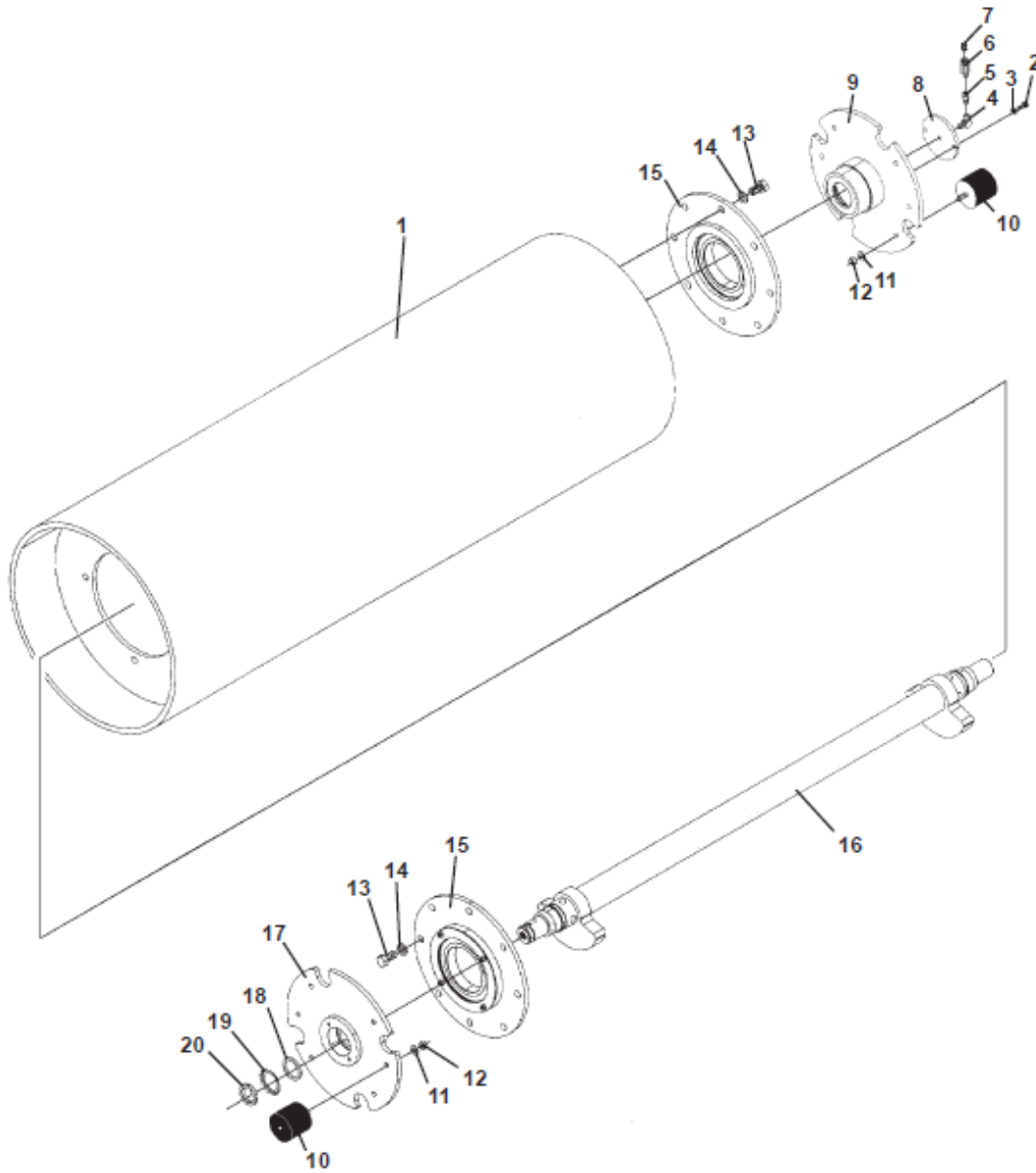

10408 4-27 -07-2

SMOOTH DRUM ASSEMBLIES

48" ASSEMBLY #105100, 66" ASSEMBLY #105101,
73" ASSEMBLY #105102, 84" ASSEMBLY #105103

<u>ITEM</u>	<u>REQ'D</u>	<u>PART NO.</u>	<u>DESCRIPTION</u>
1	1	105117	48" Smooth Drum
	1	105118	66" Smooth Drum
	1	105119	73" Smooth Drum
	1	105120	84" Smooth Drum
2	2	1043	.38" UNC X 1.00" Hex Capscrew
3	2	1503	.38" Lock Washer
4	1	3171	90° Elbow 4MP-4FP (48", 66" & 73")
5	1	3356	Straight Connector 4MP-4FP (48", 66" & 73")
6	1	30394	Inline Check Valve (48", 66" & 73")
7	1	22588	Breather Plug (48", 66" & 73")
8	1	104796	Cover Plate (48", 66" & 73")
9	1	104805	Right Inner Hub Assembly (48", 66" & 73")
	1	111443	Right Inner Hub Assembly (84")
10	12	103044	Rubber Mount
11	12	1646	.50" Hard Flat Washer
12	12	1841	.50" UNC Deformed Lock Nut
13	16	1137	.75" UNC X 1.50" Hex Capscrew
14	16	1649	.75" Hard Flat Washer
15	2	104803	Outer Bearing
16	1	105108	48" Shaft Assembly
	1	105109	66" Shaft Assembly
	1	105110	73" Shaft Assembly
	1	105111	84" Shaft Assembly
		104143	Replacement Seal Sleeve
17	1	104804	Left Inner Hub Assembly
18	1	103369	Bearing Spacer
19	1	22360	Bearing Lock Washer
20	1	22359	Bearing Lock Nut

18.

PADDED DRUM ASSEMBLIES

48" ASSEMBLY #105104, 66" ASSEMBLY #105105,
73" ASSEMBLY #105106, 84" ASSEMBLY #105107

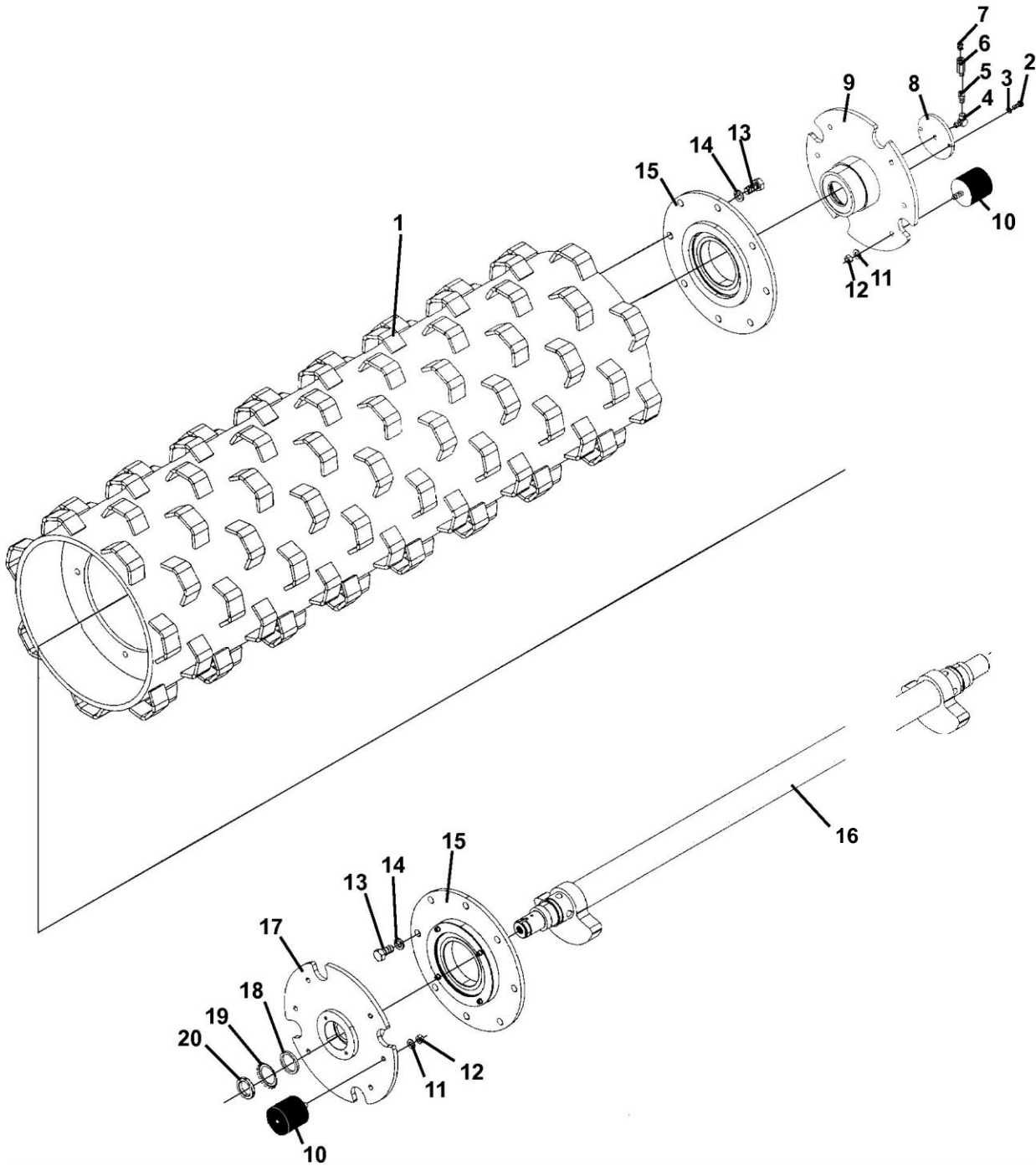

10410 4-27-07-2

PADDED DRUM ASSEMBLIES

48" ASSEMBLY #105104, 66" ASSEMBLY #105105,
73" ASSEMBLY #105106, 84" ASSEMBLY #105107

<u>ITEM</u>	<u>REQ'D</u>	<u>PART NO.</u>	<u>DESCRIPTION</u>
1	1	105121	48" Padded Drum
	1	105122	66" Padded Drum
	1	105123	73" Padded Drum
	1	105124	84" Padded Drum
2	2	1043	.38" UNC X 1.00" Hex Capscrew
3	2	1503	.38" Lock Washer
4	1	3171	90° Elbow 4MP-4FP (48", 66" & 73")
5	1	3356	Straight Connector 4MP-4FP (48", 66" & 73")
6	1	30394	Inline Check Valve (48", 66" & 73")
7	1	22588	Breather Plug (48", 66" & 73")
8	1	104796	Cover Plate (48", 66" & 73")
9	1	104805	Right Inner Hub Assembly (48", 66" & 73")
	1	111443	Right Inner Hub Assembly (84")
10	12	103044	Rubber Mount
11	12	1646	.50" Hard Flat Washer
12	12	1841	.50" UNC Deformed Lock Nut
13	16	1137	.75" UNC X 1.50" Hex Capscrew
14	16	1649	.75" Hard Flat Washer
15	2	104803	Outer Bearing
16	1	105108	48" Shaft Assembly
	1	105109	66" Shaft Assembly
	1	105110	73" Shaft Assembly
	1	105111	84" Shaft Assembly
		104143	Replacement Seal Sleeve
17	1	104804	Left Inner Hub Assembly
18	1	103369	Bearing Spacer
19	1	22360	Bearing Lock Washer
20	1	22359	Bearing Lock Nut

HUB ASSEMBLIES

REPLACEMENT PARTS

104803
OUTER HUB ASSEMBLY

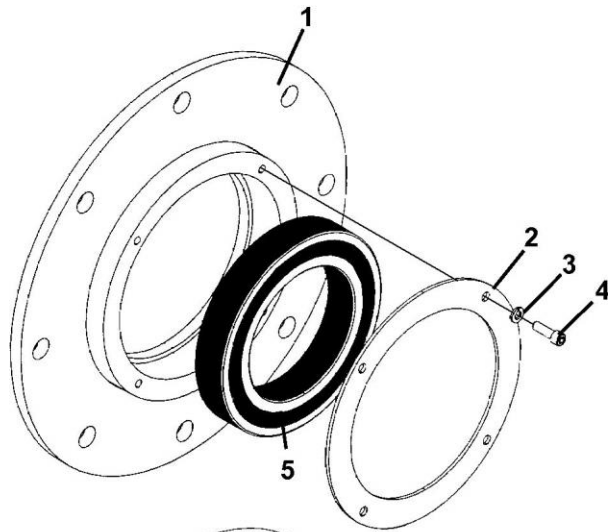

104804
LEFT INNER HUB ASSEMBLY

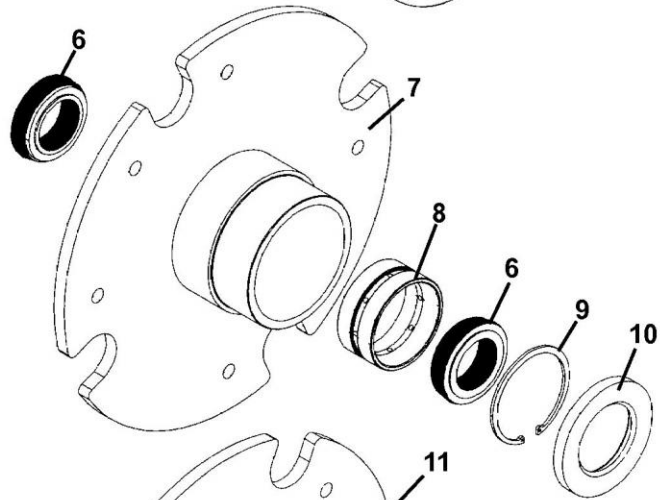

104805 (48", 66", 73")
RIGHT INNER HUB ASSEMBLY

111443 (84")
RIGHT INNER HUB ASSEMBLY

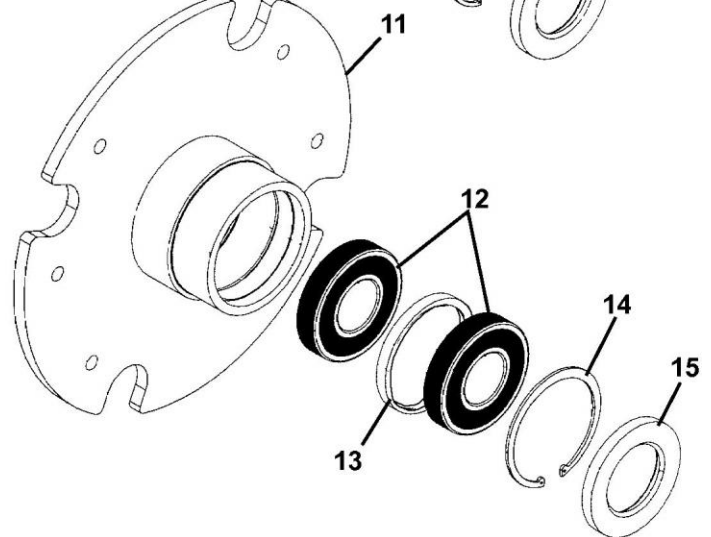

HUB ASSEMBLIES

REPLACEMENT PARTS

<u>ITEM</u>	<u>REQ'D</u>	<u>PART NO.</u>	<u>DESCRIPTION</u>
1	1	104802	Outer Hub
2	1	105578	Bearing Retainer
3	4	1502	.31" Lock Washer
4	4	10066	.31" UNC X 1.00" Socket Head Capscrew
5	1	104811	Outer Bearing
6	2	104816	Bearing Cone
7	1	104813	Left Inner Hub
8	1	104815	Bearing Cup
9	1	1681	Snap Ring 3.54"
10	1	105483	Oil Seal
11	1	104814	Right Inner Hub
12	2	107605	Bearing (48",66" & 73")
	2	111442	Bearing (84")
13	1	107387	Bearing Spacer
14	1	1681	Snap Ring 4.33"
15	1	105483	Oil Seal

HYDRAULIC ASSEMBLY

ASSEMBLY #105093

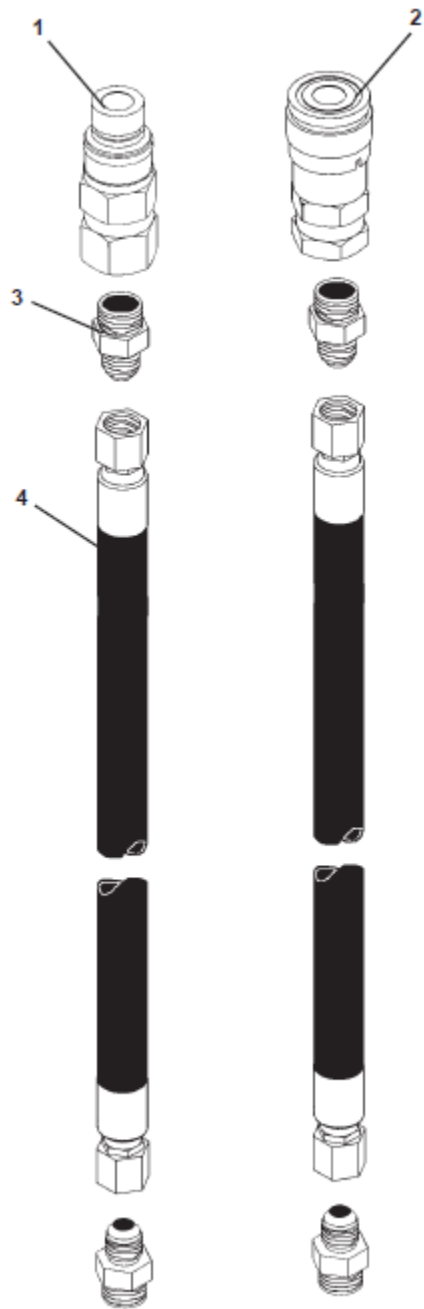

10395 9-15-05

HYDRAULIC ASSEMBLY

ASSEMBLY #105093

<u>ITEM</u>	<u>REQ'D</u>	<u>PART NO.</u>	<u>DESCRIPTION</u>
1	1	19632	Male Coupler 12FBo - Flat Face
2	1	22518	Female Coupler 12FBo - Flat Face
3	4	3102	Straight Connector 12MBo-8MJ
4	2	35434	Hose Assembly .50" X 67" 8FJX-8FJX

10396 9-15-05